

# VIRM: In-service certification (WoF and CoF) amendment

## 1 October 2023 amendment preview

September 2023

### Contents

Process for recording 28 day conditional permits .....	2
<b>Introduction.....</b>	<b>2</b>
3-7 Recording the inspection outcome ('determination') .....	2
3-8 Issuing the WoF or CoF label - 'evidence of vehicle inspection' - or temporary permit ....	2
Example images of damaged air bag bellows .....	3
<b>General vehicles .....</b>	<b>3</b>
9-1 Steering and suspension systems .....	3
Modifications to high voltage battery and control systems .....	4
<b>General vehicles .....</b>	<b>4</b>
13-5 Electric and hybrid vehicle fuel and electrical system.....	4
Requirements for inspecting caravans and motorhomes .....	5
<b>General vehicles .....</b>	<b>5</b>
3-1 Structure (incl. frontal impact).....	5
<b>General trailers .....</b>	<b>6</b>
3-1 Structure.....	6
<b>Heavy vehicles .....</b>	<b>7</b>
3-1 Structure.....	7
<b>Heavy trailers .....</b>	<b>8</b>
3-1 Structure.....	8
Overlay requirements for PSVs .....	10
<b>Light PSVs and Heavy PSVs .....</b>	<b>10</b>
6-4 PSV emergency exits .....	10
Left-hand drive all-terrain vehicles.....	11
<b>Unclassified vehicles.....</b>	<b>11</b>
1 Introduction.....	11
9-1 Steering and suspension systems .....	11
New jacking point image .....	12
<b>Technical bulletins (general).....</b>	<b>12</b>
4 Jacking points for common suspension types .....	12

# Process for recording 28 day conditional permits

## Introduction

### 3-7 Recording the inspection outcome ('determination')

We're adding a clause to clarify the process for recording a 28 day conditional permit.

#### Applicable legislation:

[Land Transport Rule: Vehicle Standards Compliance 2002](#), section 7.6

1. The inspection outcome is recorded in either the WoF Online system or the LATIS system.
2. The inspection details must be entered into the system before the vehicle leaves the inspecting organisation's premises. This ensures that:
  - a) the vehicle can be relicensed by the vehicle owner
  - b) the correct inspection frequency can be ascertained
  - c) any restrictions placed on the vehicle are identified before issuing a WoF or CoF, such as a ban flag or a pink or green sticker
  - d) any vehicle issued with a 28 day conditional permit must have the fail determination entered into LATIS first, then the 28 day permit must be entered with the fault codes and any conditions imposed. Refer to sections 7.9 and 7.10a.
3. Inspection details entered into the system must be accurate at the time the vehicle was inspected. This includes updating the odometer and hubodometer readings when a vehicle is re-presented for inspection.
4. For vehicles required to operate under a TSL, vehicle inspectors must also collect and record in the system the TSL number for both passed and failed inspections, and when issuing temporary permits.

### 3-8 Issuing the WoF or CoF label - 'evidence of vehicle inspection' - or temporary permit

Same note added as above.

9. specified conditions relating to the vehicle's operation, and
  10. date of issue of the permit, and
  11. signature of the vehicle inspector.
- These details must be clearly legible on both copies of the permit.
  - Each permit has a unique serial number which must be recorded on both copies of the checksheet.
  - Any vehicle issued with a 28 day conditional permit must have the fail determination entered into LATIS first, then the 28 day permit must be entered with the fault codes and any conditions imposed. Refer to sections 7.9 and 7.10a of [Land Transport Rule: Vehicle Standards Compliance 2002](#).

## Example images of damaged air bag bellows

We're adding images to help vehicle inspectors identify excessive damage to air bag suspension systems.

### General vehicles

#### 9-1 Steering and suspension systems

8. A **lock stop** is loose, damaged or missing.

9. **Air bag bellows** has obvious external damage – protruding or worn cords [\(Figure 9-1-2\)](#).

**Note:** Assessment to be conducted:

- At standard ride height (air bellows inflated)
- Normal air pressure
- Soap and water for leakage test is acceptable.

10. A **steering or suspension component mounting point**:

- a) is insecure, or
- b) has corrosion damage [\(Note 1 i\)](#), buckling or fractures within 150mm of a mounting point [\(Figure 9-1-1\)](#).

**Figure 9-1-2. Sample air bag bellows images**



# Modifications to high voltage battery and control systems

We're updating the VIRM to include EV, HEV & PHEV modifications that do not require Low Volume Vehicle Technical Association (LVVTA) certification

## General vehicles

### 13-5 Electric and hybrid vehicle fuel and electrical system

Table 13-5-1. Modifications that do not require specialist certification

Fitting of or modification to:	Specialist certification is not required provided that:
Fuel system changes and modifications	<ul style="list-style-type: none"> <li>see fuel system requirements in <a href="#">Table 13-2-1</a>.</li> </ul> <p>Note: Specialist certification is <b>always</b> required for changes to the high voltage electrical system.</p>
High voltage battery and control systems	<ul style="list-style-type: none"> <li>the high voltage battery pack is replaced by an OEM or aftermarket replacement; and</li> <li>there is no change in the operating voltage; and</li> <li>no modifications to the vehicles structure have occurred; and</li> <li>the replacement battery pack is attached to the vehicle's unmodified, original battery attachment points; and</li> <li>the replacement battery pack is similar in size, construction, and weight; and</li> <li>no modifications have occurred to any other part of the vehicle's high voltage system; and</li> <li>the vehicle retains any safety features (eg isolation/maintenance switch/connector) fitted by the OEM manufacturer; and</li> <li>the modifications have been carried out by persons professionally engaged in the modification of electric vehicles.</li> </ul> <p>Note: For clarity, 'similar weight' is within 30kg of the original battery pack weight.</p>

# Requirements for inspecting caravans and motorhomes

The recent influx of used caravans and motorhomes manufactured for the European market has created an issue where any damage in the form of wood rot in floor or decking used in the construction of the vehicle could compromise the structural rigidity.

The VIRM refers to corrosion with steel components, chassis, floor, panels etc, and gives good guidance on what to be aware of when inspecting the vehicle, but it was never envisaged that wood would be used for structural integrity.

The above vehicles are designed and manufactured for the European market which has a very different roading network to New Zealand. Stress and moisture damage are starting to show up at WoF/CoF inspections and VIs are seeking guidance on the expected condition and performance of the structures.

We're amending the VIRM to take these materials into account.

## General vehicles

### 3-1 Structure (incl. frontal impact)

#### Condition

1. The structure of the vehicle (shaded areas of [Figure 3-1-2](#)) has visible:

- a) deformation from the original shape that has affected the vehicle's structural integrity ([Note 1](#)) ([Note 3](#)) ([Note 9](#)) ([Figure 3-1-4](#)), or
- b) cracking, or
- c) fracture, or
- d) corrosion **or wood rotting** damage ([Note 2](#)) that is individually larger than 50mm in diameter ([Figure 3-1-1](#)), or
- e) corrosion **or wood rotting** damage within 150mm of the top of an A-pillar ([Figure 3-1-2](#)), or
- f) any corrosion **or wood rotting** that the inspector considers has caused weakening of a load-bearing structure ([Note 6](#)), or
- g) poor repairs that have not returned the structure to within a safe tolerance of when it was manufactured ([Note 3](#)) ([Note 6](#)),  
eg:
  - i. filler has been used in an attempt to conceal **corrosion** **any** damage or deformation of a component
  - ii. a high strength steel component has been heated
  - iii. a component has been strengthened.

#### Note 2

**Corrosion or wood rotting damage** is where **the a metal or wooden structure** has been eaten away, ~~which is evident by~~ **and could be seen as bubbling, or pitting of the steel or by water damage, delamination or swelling of a wooden surface**. The outward signs of such **corrosion** damage is typically displayed by the lifting, **bubbling or discolouring of painted surfaces or bubbling of paint**. In extreme cases, the area affected by the **corrosion** damage will fall out and leave a hole.

**Bumper bar** means either the part inside a plastic bumper or a complete metal bumper as used on older vehicles. The bumper fascia (bumper cover) is not part of the bumper structure. It is the bumper reinforcement (also known as the bumper bar) that is the actual bumper bar for inspection purposes (see [Figure 3-1-3](#)).

#### Note 3

The vehicle inspector may request additional relevant information from a repairer or other relevant person. The vehicle inspector should withhold the warrant of fitness if there is reason to believe that the vehicle has:

- a) structural damage, or
- b) inadequate structural repair(s), or
- c) corrosion **or wood rotting damage**

to the extent that it could affect the vehicle's structural strength or one of the vehicle's safety requirements.

# General trailers

## 3-1 Structure

### Condition

1. The structure of the vehicle (shaded areas of [Figure 3-1-2](#)) has visible:
  - a) deformation from the original shape that has affected the vehicle's structural integrity ([Note 2](#) ⓘ), or
  - b) cracking ([Note 3](#) ⓘ) ([Figure 3-1-3](#)), or
  - c) fracture, or
  - d) corrosion **or wood rotting** damage ([Note 1](#) ⓘ) that is individually larger than 50mm in diameter ([Figure 3-1-1](#)), or
  - e) any corrosion **or wood rotting** that the inspector considers has caused weakening of the load-bearing structure, or
  - f) poor repairs ([Note 1](#) ⓘ) that have not returned the structure to within a safe tolerance of when it was manufactured ([Note 2](#) ⓘ), such as:
    - i. filler has been used in an attempt to conceal **corrosion** **any** damage or deformation of a component, or
    - ii. a high strength steel component has been heated.
2. A hinge for a panel is not securely attached to both the vehicle body and to the door or other hinged panel due to loose connections, corrosion, **wood rotting** or other damage.
3. There is corrosion **or wood rotting** damage within 150mm of the hinge of a hinged panel ([Figure 3-1-4](#)).
4. There is corrosion **or wood rotting** damage within 150mm of the latch of a hinged panel ([Figure 3-1-4](#)).

### Note 1

**Corrosion or wood rotting damage** is where **the a metal or wooden structure** has been eaten away, **which is evident by and could be seen as bubbling, or pitting of the steel or by water damage, delamination or swelling of a wooden surface**. The outward signs of such **corrosion** damage is typically displayed by the lifting, **bubbling or discolouring of painted surfaces or bubbling of paint**. In extreme cases, the area affected by the **corrosion** damage will fall out and leave a hole.

**Repair** means to restore a damaged or worn vehicle, its structure, systems, components or equipment to within safe tolerance of its condition when manufactured, including replacement with equivalent undamaged or new structures, systems, components or equipment.

**Figure 3-1-1. Corrosion or wood rotting damage 50mm diameter limit**

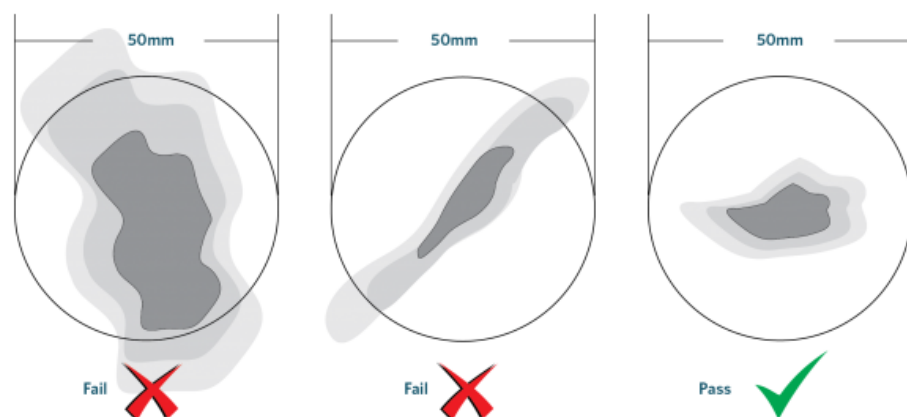

**Figure 3-1-2. Shaded areas referred to in 'Condition' above**

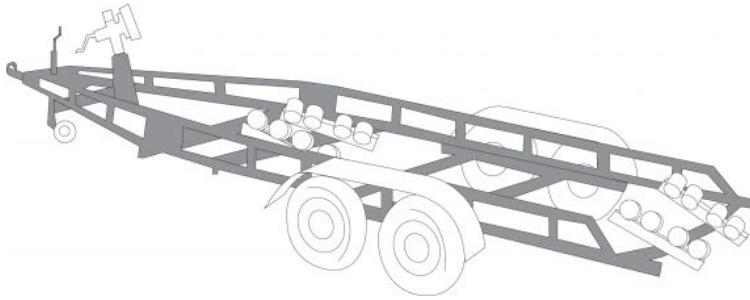

These include: chassis, cross members and subframes, load-bearing monocoque body structures, body mounts, and the body on a trailer with a separate chassis:

- a) The chassis rails, cross members, subframes, suspension and body mounting points of a vehicle with a separate chassis, and
- b) the load-bearing structure of a monocoque body, including body mounting points, and
- c) the body fitted to a trailer where the structure supports the chassis, similar to a unitary body (for example, some livestock carriers, horse floats, and UK-sourced caravans with wooden or wood laminate structures).

**Figure 3-1-4. Hinge and latch anchorages**

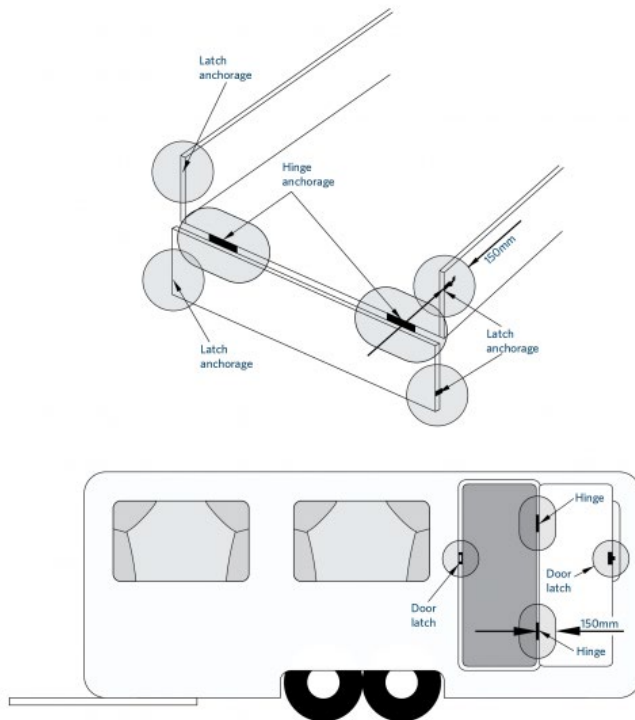

No corrosion structural damage is allowed within 150mm of a circle around the outside of hinge or latch components a hinge, latch or load anchorage component.

## Heavy vehicles

### 3-1 Structure

Please note the subsequent reason for rejection has been renumbered accordingly (what was reason 11 is now reason 12).

10. A bin securing device does not operate correctly.

11. A vehicle which uses a wooden or wood laminate floor as a structural component of the chassis has:

- a) deformation from original shape that has affected the vehicle's structural integrity (Note 6 ) (Figure 3-1-4), or
- b) significant cracking of the body structure or mounting points, or
- c) significant corrosion of steel elements, delamination, or wood rotting or
- d) significant rust heave in steel elements that exceeds the limits in (Figure 3-1-3), or
- e) poor repairs that have not returned the structure to within safe tolerance of when it was manufactured, for example:
  - i. filler has been used to conceal any damage or deformation of a component
  - ii. a high-strength steel component has been heated
  - iii. a component has been strengthened.

## Heavy trailers

### 3-1 Structure

Please note the subsequent reason for rejection has been renumbered accordingly (what was reason 10 is now reason 11). We've also copied Note 5 and Figure 3-1-4 over from the *Heavy vehicles* section.

10. A vehicle which uses a wooden or wood laminate floor as a structural component of the chassis has:

- a) deformation from original shape that has affected the vehicle's structural integrity (Note 5 ) (Figure 3-1-4), or
- b) significant cracking of the body structure or mounting points, or
- c) significant corrosion of steel elements, delamination, or wood rotting or
- d) significant rust heave in steel elements that exceeds the limits in (Figure 3-1-3), or
- e) poor repairs that have not returned the structure to within safe tolerance of when it was manufactured, for example:
  - i. filler has been used to conceal any damage or deformation of a component
  - ii. a high-strength steel component has been heated
  - iii. a component has been strengthened.

#### Note 5

Dents smaller than 5mm deep and 40mm in diameter (to the outer edges of the crease), such as those caused by hail, in the pillars, cant rail or any other similar roof structure, should not be considered to affect the vehicles structural integrity. Any damage larger than above should be referred to a repairer for additional information (see Figure 3-1-4).



**Figure 3-1-4. Deformation limits**

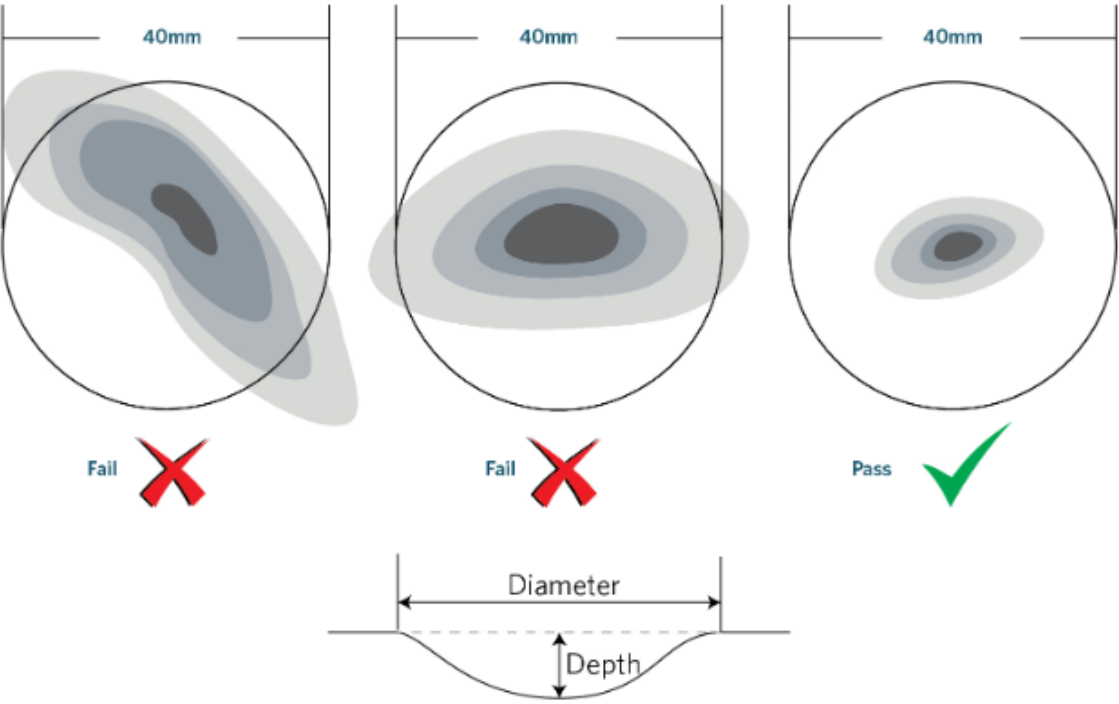

# Overlay requirements for PSVs

We're clarifying requirements for overlays on dedicated glass-break emergency exits on PSVs. This is a result of testing to determine allowable limits.

## Light PSVs and Heavy PSVs

### 6-4 PSV emergency exits

#### Dedicated emergency exits (Note 4

4. A breakable-glass dedicated emergency exit does not have a device, (eg a hammer) that is capable of breaking the glass, fitted in a prominent position on or next to the glass inside the PSV.

5. The glazing of a breakable-glass dedicated emergency exit:

- a) is laminated, or
- b) is not made of readily breakable, toughened safety glass (refer to [section 5-1](#) of this manual for markings), or
- c) has been modified, covered or treated in a way which might adversely affect the breakability or the removal of the glass, eg it has a vinyl overlay ([Note 7 !\[\]\(c6a8736a601a632e2c96605cf66055ed\_img.jpg\)](#)).

#### Note 7

An overlay may be fitted providing it has a gap of at least 4mm between the overlay material and the window edge where it meets the rubber seal or the edge of the adhesive. The gap must be around the entire perimeter of the exit and around a burst device.

# Left-hand drive all-terrain vehicles

WoFs are being issued in error to left-hand drive side by sides, which is prohibited by section 2.5 of the Steering Rule. We're updating the *Unclassified vehicles* section to address this.

## Unclassified vehicles

### 1 Introduction

We're adding a note to clarify that a WoF cannot be issued to a left-hand drive all-terrain vehicle (ATV).

- u) trench diggers and excavators
- v) vehicles that are always used unladen on the road and that are designed exclusively for carrying earth or other bulk materials
- w) mobile concrete mixers that are mounted on tractors
- x) a vehicle that is similar in design, construction or purpose to a vehicle listed above that cannot be categorised by vehicle class
- y) [all-terrain vehicles](#) (Note 1 ⓘ).

8. As this section applies to both self-propelled vehicles and trailers, separate requirements have been indicated where appropriate.

#### Note 1

A WoF cannot be issued to a left-hand drive all-terrain vehicle (ATV).

### 9-1 Steering and suspension systems

We're adding a new Reason for rejection to address left-hand drive ATVs.

Please note the subsequent reasons have been renumbered accordingly (what was reason 2 is now reason 3, and so on).

#### Condition

2. An all-terrain vehicle (ATV) is in left-hand drive configuration.

3. The steering wheel or a control lever:

- a) is insecurely attached to the steering shaft, or
- b) shows excessive movement, eg due to unacceptable wear or looseness in the steering box or rack or steering column bearings, or
- c) rim covering is insecure so that the directional control of the vehicle is affected.

4. The steering column is insecure.

# New jacking point image

## Technical bulletins (general)

### 4 Jacking points for common suspension types

We're updating the wording and adding a new jacking point image (double wishbone, spring strut acting on lower arm).

#### Safety concern

Excessive wear in **and subsequent failure of** suspension ball joints can seriously affect the safe handling of the vehicle - **if left unchecked, subsequent failure could cause a crash. Modern suspension systems employ multiple control arms, ball joints and compliance bushings, so it's important to check them all carefully during an inspection.**

#### Inspection

To ensure that ball joint wear can be correctly detected, it is important that the vehicle is jacked up correctly, depending on which type of suspension the vehicle is fitted with. The jacking points for common types of suspension are illustrated below.

To help ensure ball joint wear is correctly detected, the images below show the jacking points for some common suspension types. They do not cover all suspension types or versions.

It's vital that the vehicle is jacked up correctly to avoid any damage. Depending on the type of suspension fitted to the vehicle, you may need to seek the manufacturer's guidance.

