

The inspection described in this form must have been done less than 30 days and fewer than 15,000km before the CoF inspection in which it is used. A technician must do the inspection. The form can be form signed by either a technician or the operator.

Operators must maintain the skid plate assembly on their vehicles in accordance with best practice. This form is used by a heavy vehicle operator to confirm a vehicle's skid plate structural condition is within safe tolerances and must be presented at CoF inspection. Complete as much detail as possible (where you don't know the information, write N/A).

### Details

Statement number (operator to allocate number)      Registration plate number      Hubodometer reading

Make      Model

VIN/chassis

### Inspection by technician (service technician to complete)

The kingpin and skid plate must be thoroughly steam cleaned for this inspection.

Using a skidplate/kingpin gauge, inspect the following (dimensions provided for 50mm kingpin):

Pass	Fail	
1	<input type="checkbox"/>	Signs of pitting, deep grooves, or unusual wear
	<input type="checkbox"/>	Pass with advisory Provide a brief explanation. Specialist advice will be required before the next CoF
2	<input type="checkbox"/>	Cracks or deformation in skid plate or surrounding structure
3	<input type="checkbox"/>	Skid plate flatness (as per drawings to the right)
4	<input type="checkbox"/>	Skid plate to kingpin squareness ( $90^\circ \pm 1^\circ$ )
5	<input type="checkbox"/>	Mounting height (70mm, replace at 73mm**)
6	<input type="checkbox"/>	Throat size - all around (new is $\varnothing 50.8\text{mm}$ , replace at $\varnothing 48\text{mm}^*$ )
7	<input type="checkbox"/>	Top flange (shoulder) size (new is $\varnothing 73\text{mm}$ , replace at $\varnothing 70\text{mm}^*$ )
8	<input type="checkbox"/>	All bolts present (and properly torqued if replacing kingpin)

\* In absence of manufacturer's specific guidance

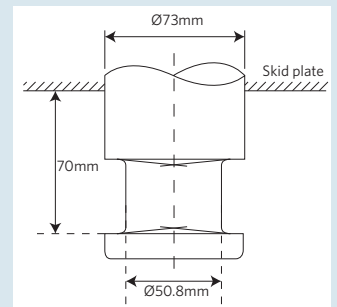
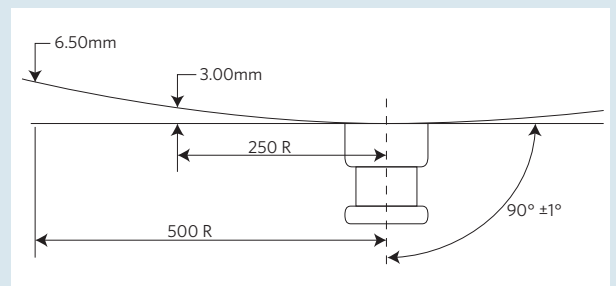
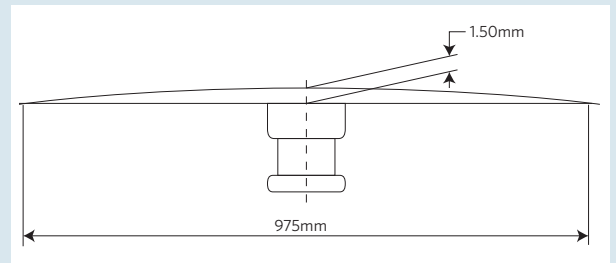

Name of service company      Service inspection carried out by

Technician's signature      Date

### Operator's declaration

Name of operator

I have management responsibility for the maintenance of the above vehicle, and affirm that the vehicle's skid plate coupling assembly has been checked and found to be within the parameters and intent of this document and the Transport Agency's Heavy vehicle servicing: Skid plate inspection information sheet.

Operator's signature      Date