

Correct as at 17th May 2026. It may be superseded at any time.

Extract taken from: In-service certification (WoF and CoF) > General trailers > Tyres, wheels and hubs > Mudguards

## 7-3 Mudguards

### Reasons for rejection

#### Mandatory equipment

1. A mudguard (Note 1) over a road wheel is missing where it is reasonable and practicable to fit a mudguard, unless the trailer is:

a) in an unfinished condition legally used under the authority of trade plates, or

b) is towed by a vehicle that is not capable of exceeding a speed of 30 km/h.

2. A mudguard does not cover the full tread (Note 1) width of a tyre or tyres fitted to a road wheel (Figure 7-3-1), except on a trailer designed for industrial purposes where it is not practicable to fit a full mudguard due to the vehicle's construction.

3. A trailer used for transporting round timber is not fitted with at least partial mudguards mounted behind the rearmost axle that meet the following requirements (Figure 7-3-2):

- the mudguard must provide continuous protection from a horizontal at the top of the tyre to a line rising rearward with a slope of 1 in 3 from the tyres contact point on the road, and
- the distance between the tyre and the mudguard must not be more than twice the distance from the centre of the wheel to the road.

4. On a vehicle with twin or close-spaced multiple tyres a mudguard fitted over a wheel on the rear axle is more than one-third higher than the horizontal distance between the vertical lines of the lowest point of the mudguard and the centre of the wheel (Figure 7-3-2), except when the mudguard is fitted to a vehicle designed for industrial purposes and it is not practicable to fit a full mudguard due to the vehicle's construction.

#### Mudguard condition

5. A mudguard is not securely fixed to the vehicle.

6. A mudguard is so constructed or damaged that it is likely to present a hazard to road users.

#### Note 1

**Mudguard** means a fitting, inclusive of any portion of the vehicle and of any mudflaps attached, that serves to intercept material thrown up by a wheel more or less on the plane of the wheel.

**Tyre tread** means the portion of a tyre that contacts the road.

Figure 7-3-1. Position of mudguard in relation to tyre tread

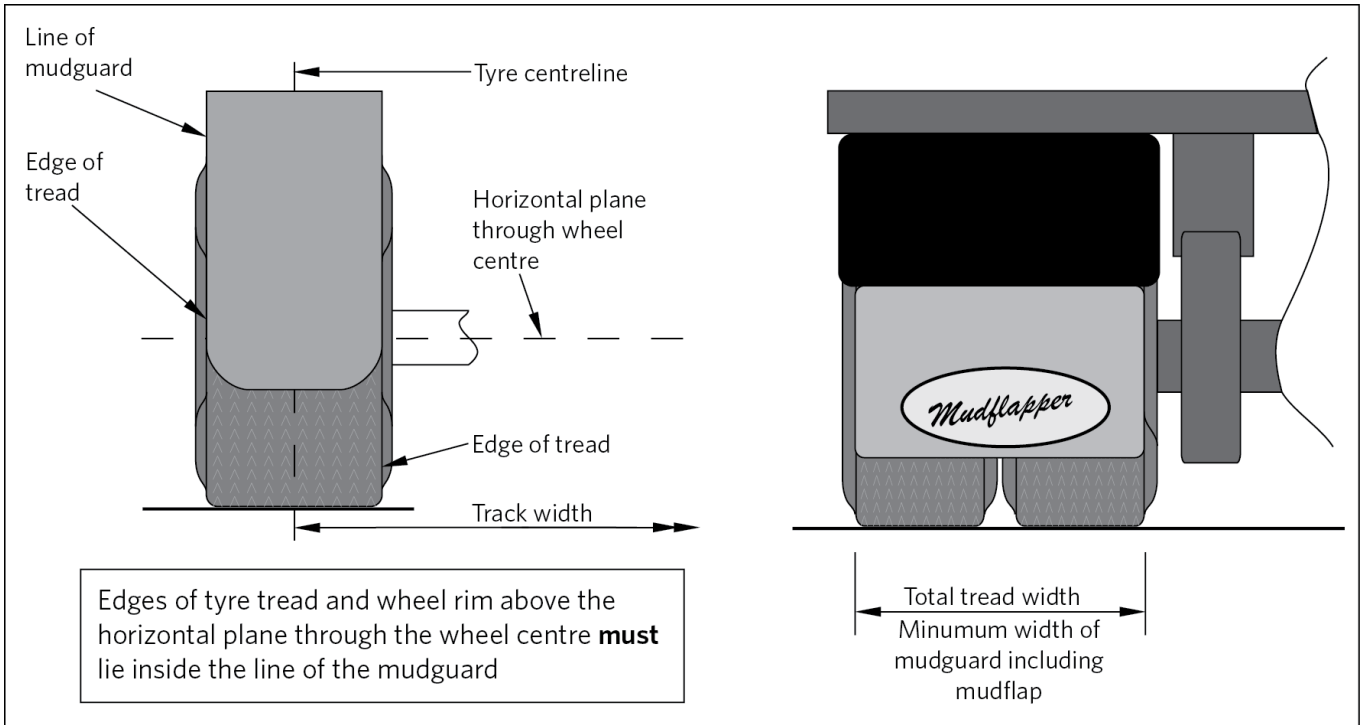
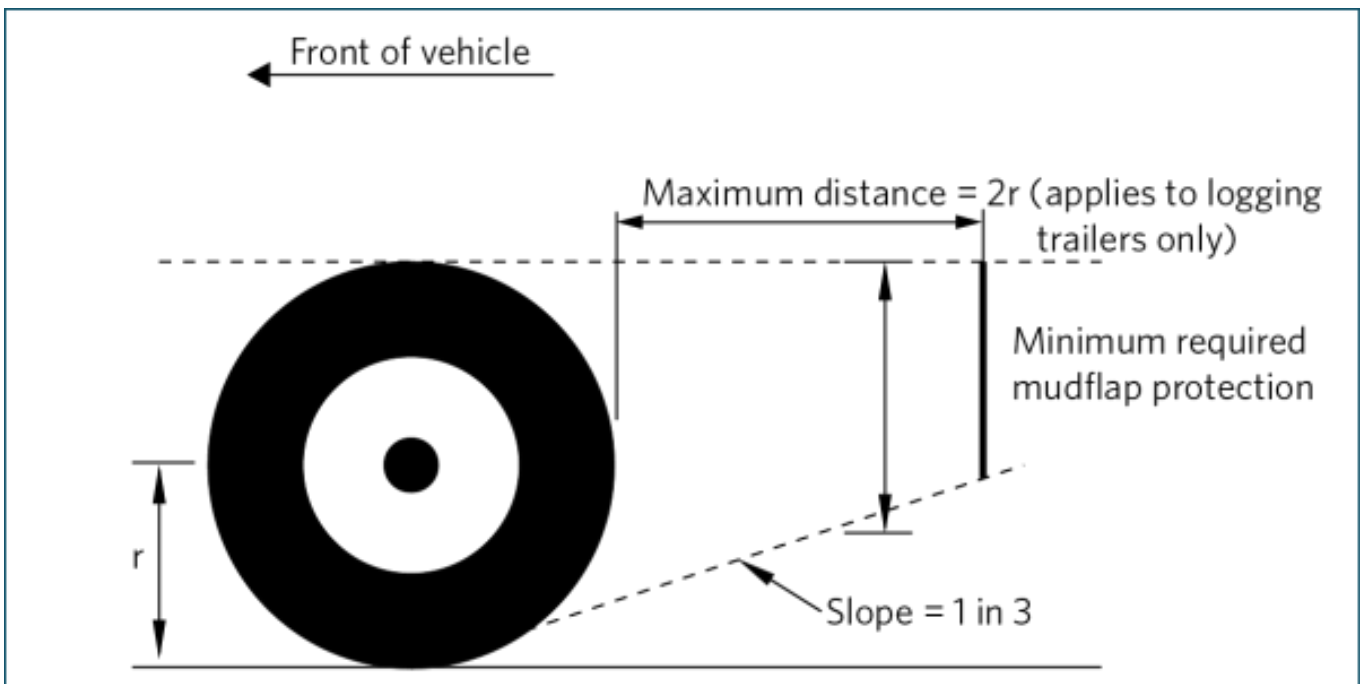

Figure 7-3-2. Size and position of mudguards for the rear wheels of a trailer fitted with dual wheels or close-spaced multiple wheels and logging trailers



## Summary of legislation

### Applicable legislation

- [Land Transport Rule: Tyres and Wheels 2001](#)

- [Land Transport Rule: Vehicle Equipment 2004](#)

### **Mandatory equipment**

1. A trailer must be fitted with a mudguard (Note 1) over each road wheel if it is reasonable and practicable to do so.
2. A mudguard must cover no less than the width of the tyre tread on each road wheel (Figure 7-3-1).
3. A trailer fitted with twin tyres or close-spaced multiple tyres must be fitted with a mudguard over each wheel on the rear axle that provides continuous protection from a horizontal line tangent to the top of the tyre tread (Note 1) to a line with a slope of 1 in 3 rising rearward from the tyre's contact point on the road (Figure 7-3-2).
4. A trailer designed for industrial purposes may be fitted with partial mudguards if the vehicle's construction makes it impracticable to fit full mudguards.
5. A trailer used for transporting round timber that cannot be fitted with mudguards over each road wheel must have at least partial mudguards mounted behind its rearmost axle that comply with the following (Figure 7-3-2):
  - a) the mudguard must provide continuous protection from a horizontal line tangent to the top of the tyre tread to a line with a slope of 1 in 3 rising rearward from the tyre's contact point on the road, and
  - b) the distance between the tyre and the mudguard must not be more than twice the tyre rolling radius.
6. The following trailers are not required to be fitted with mudguards:
  - a) a vehicle in an unfinished condition used under the authority of trade plates and operated in accordance with the Compliance Rule
  - b) a trailer towed by a vehicle that is not capable of exceeding a speed of 30 km/h.

### **Mudguard condition**

7. A mudguard must be securely fixed to the vehicle and must be constructed so that it does not present a hazard to road users.