

Correct as at 26th April 2026. It may be superseded at any time.

Extract taken from: Entry certification > Inspection and certification > Entrance and exit > PSV doors and doorways (light PSVs)

6-2 PSV doors and doorways (light PSVs)

Reasons for rejection

Mandatory requirements

1. A doorway does not meet the dimension requirements of Table 6-2-1
2. A vehicle does not comply with the requirements relating to mandatory equipment set out in the [VIRM: In-service certification, section 6-2](#)

Condition and performance

3. A PSV door or doorway does not comply with the requirements relating to condition and performance set out in the [VIRM: In-service certification, section 6-2](#)

Table 6-2-1. Minimum width and height for PSV doorways

A doorway that:	Minimum width (mm)	Minimum height (mm)
Gives access to less than three rows of seats and less than eight occupants (Figure 6-2-1)	No minimum but must give easy access	No minimum but must give easy access
Is un-tapered with no central stanchion	550	Same as minimum aisle height (see section 7-4), except: <ol style="list-style-type: none"> 1. the rear door of an outdoor-access vehicle may have reduced height if this is required for additional frame strength, or 2. the door height may be reduced to 1650mm for a PSV that: <ol style="list-style-type: none"> a) is one of a series of identical vehicles produced in quantities of 1000 or more, and b) does not have more than 25 passenger seats, and c) has a GVM not exceeding 7000kg.
With central stanchion	550 each side of stanchion	
Is tapered at the top to accommodate body shape	See Table 6-2-2	
Is intended for wheelchair access (Figure 6-2-2)	800	1300 top of sill to doorway top

Table 6-2-2. Minimum width for tapered doorways (Figure 6-2-3)

Height above doorway sill (mm)	Minimum width (mm)
1600 or less	550
1601 to 1800	450
1801 to 1830	400
1831 and above	380

Figure 6-2-1. Entrance and exit

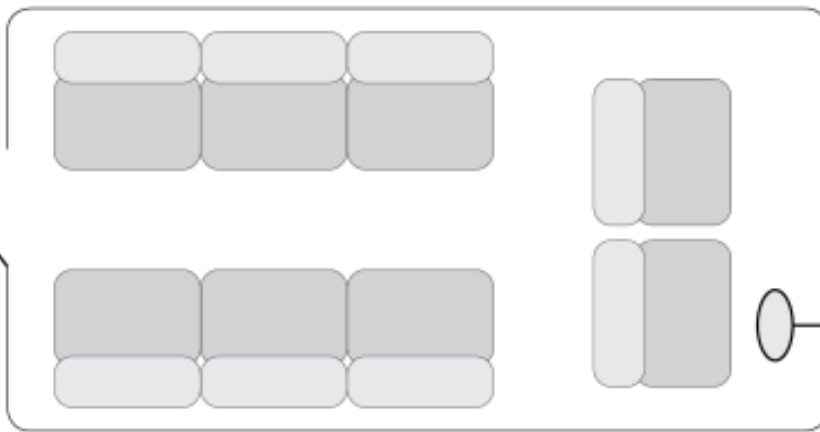
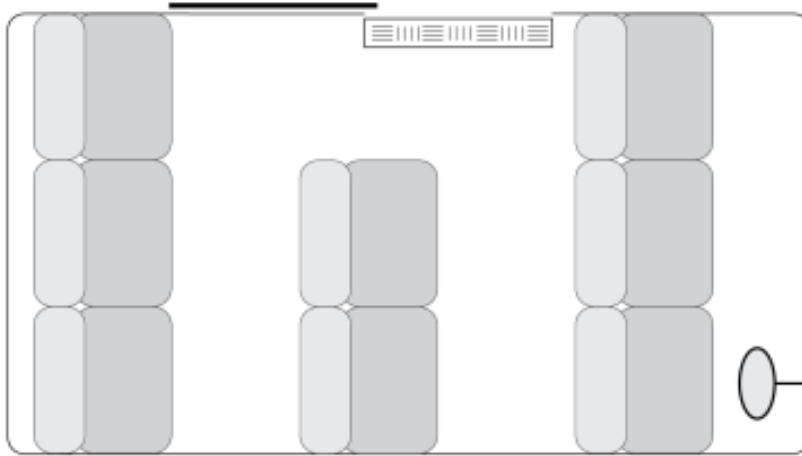

No specific dimension requirements but there must be easy entrance and exit

Figure 6-2-2. Doorway intended for wheel chair access

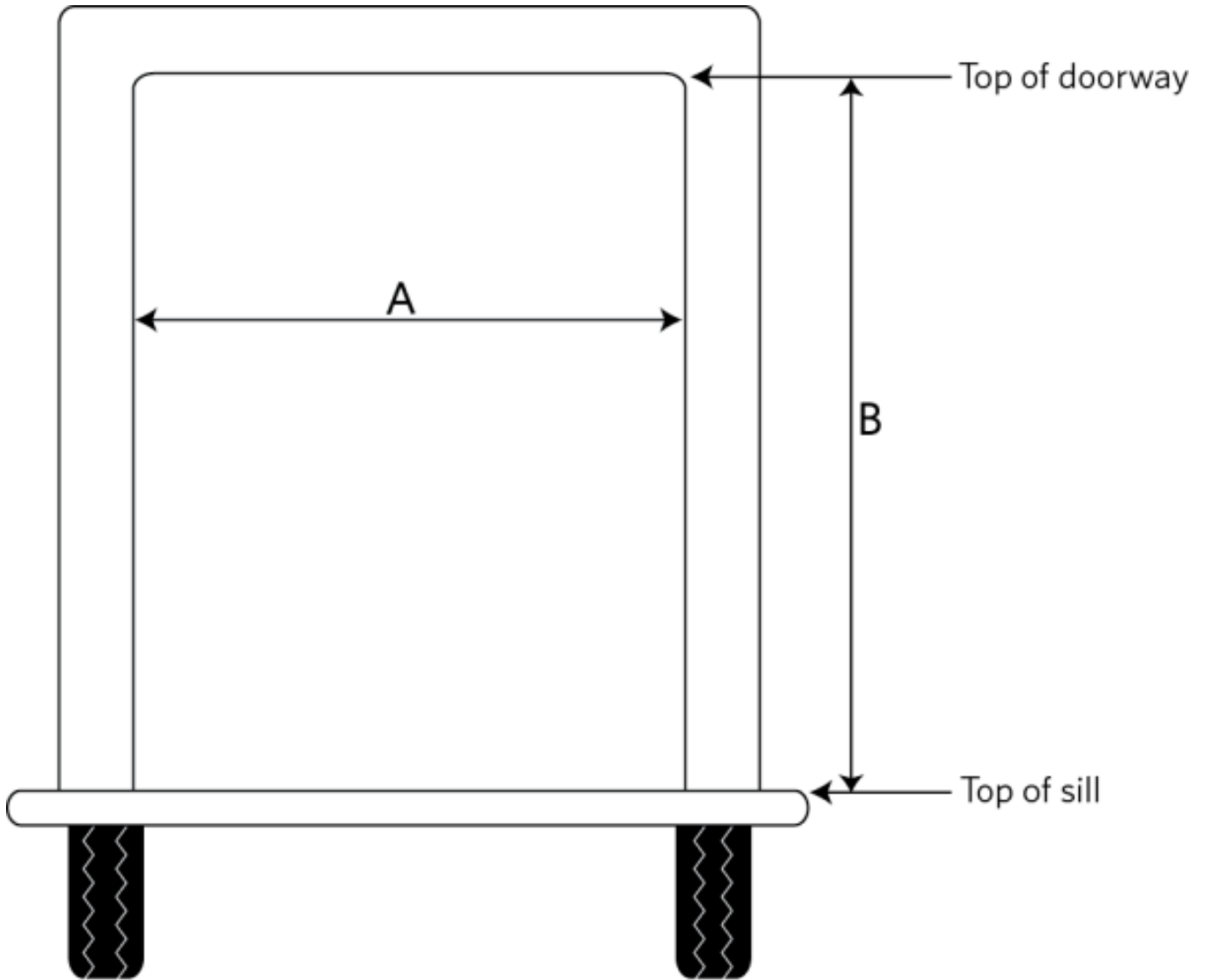

'A' must be at least 800 mm
'B' must be at least 1300 mm

Figure 6-2-3. Tapered doorways

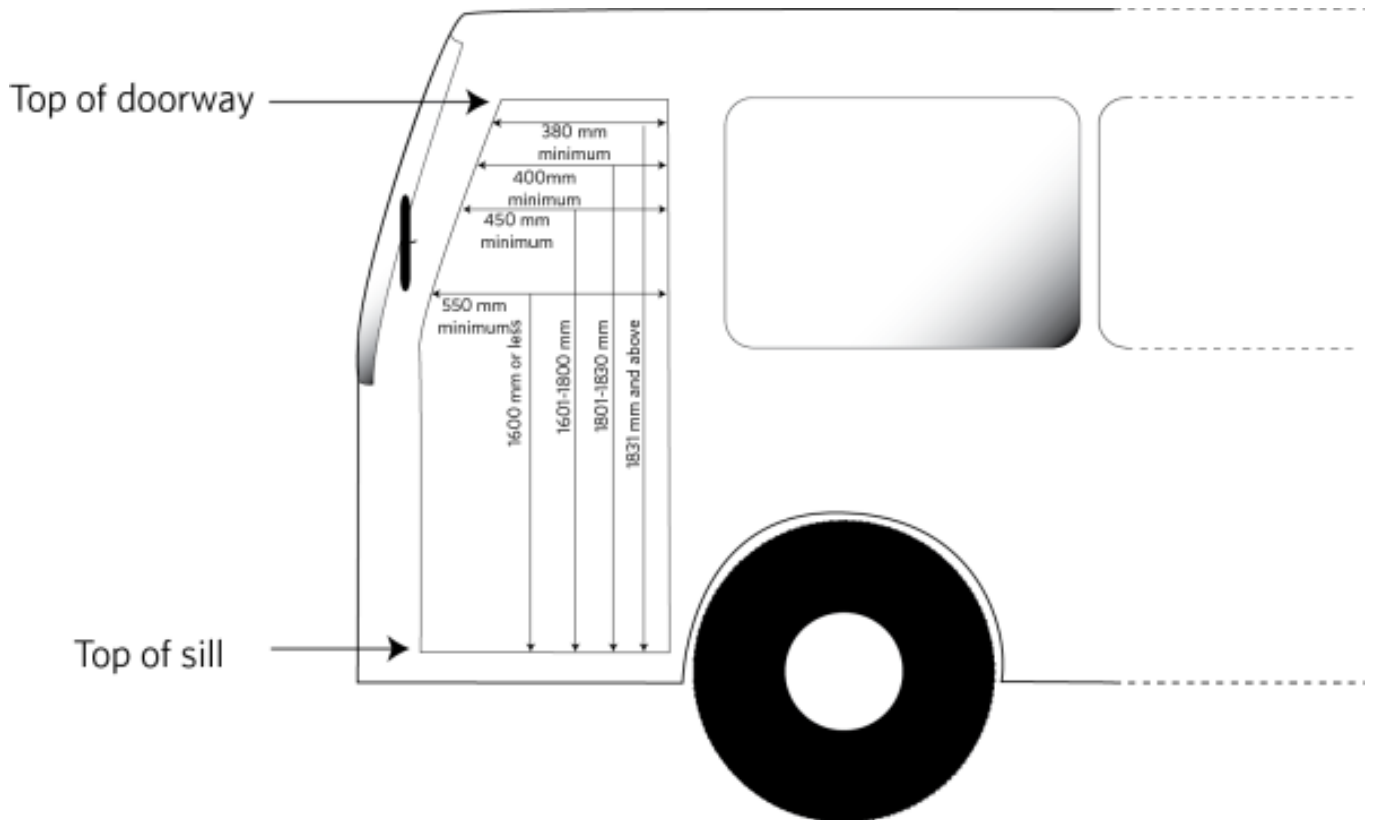

Summary of legislation

Applicable legislation

- [Land Transport Rule: Passenger Service Vehicles 1999](#)

Mandatory requirements

1. The dimensions of a doorway must be at least those specified in Table 6-2-1
2. Vehicles must comply with the requirements relating to mandatory equipment set out in the [VIRM: In-service certification, section 6-2](#)

Performance

3. PSV doors and doorways must comply with the requirements relating to performance set out in the [VIRM: In-service certification, section 6-2](#)