

Correct as at 23rd June 2026. It may be superseded at any time.

Extract taken from: In-service certification (WoF and CoF) > Light PSVs

Light PSVs

1 Vehicle identification

1-1 VIN and chassis number

Important Ensure that the VIN or chassis number is recorded in full on the checksheet.

This number must be:

- the VIN if fitted – not the chassis number (locally allocated VIN)
- the stamped VIN on the VIN plate – not the VIN etched on the glazing.

Also refer to **Table 1-1-1. Location of New Zealand VIN numbers**, **Figure 1-1-1. Structure of a VIN issued by the NZ Transport Agency** and **Figure 1-1-2. Structure of a VIN issued by the vehicle manufacturer**.

Reasons for rejection

Mandatory requirements

1. A vehicle first registered or re-registered in New Zealand before 1 April 1994 does not have a VIN or chassis number (Note 1) (Note 3).
2. A vehicle first registered or re-registered in New Zealand from 1 April 1994 does not have a VIN number (Note 1) (Note 3).
3. A VIN number is not valid (Note 1) (Note 2).

Condition

4. A VIN or chassis number has been (Note 1) (Note 3):
 - a) removed, or
 - b) erased, or
 - c) altered, or
 - d) defaced, or
 - e) obscured, or
 - f) destroyed, or
 - g) obliterated, or
 - h) affixed unlawfully or by unauthorised persons.

Note 1

The vehicle inspector must notify NZTA using the *Vehicle report* form if there is reason to believe that the VIN or chassis number has been tampered with in any way.

Vehicle report form

The vehicle inspector must not issue a WoF/CoF/permit until approved by NZTA. Approval will usually include the issue or re-issue of a new VIN plate.

The vehicle inspector must not issue a WoF/CoF/permit if there is reason to believe that the VIN or chassis number has been tampered with in any way.

Refer the vehicle to a VIN issuing agent ([VTNZ](#), [VINZ](#), [NZAA](#), [Drivesure](#), [CVC](#), [Autochecks](#)). They will inspect the vehicle and seek approval from NZTA to issue or re-issue a VIN plate. Once the vehicle has been approved the vehicle may continue through the inspection process.

Note 2

A valid VIN is a unique number that has been assigned to the vehicle in the vehicle's country of origin or by a person appointed by the NZTA. It consists of 17 characters that never contain the letters I, O or Q, and that is capable of being decoded to provide identifying information about the vehicle.

Note 3

If the vehicle is failed because the VIN/chassis is missing or unreadable, then 'not found' must be recorded in place of the VIN number on the check sheet.

Table 1-1-1. Location of New Zealand VIN numbers

Vehicle	Permitted VIN locations
Vehicles that are not forward controlled (passenger cars and off-road passenger vehicles)	<ul style="list-style-type: none"> • In the engine compartment on the right-hand side of the firewall • In the engine compartment on the right-hand side adjacent to the front suspension mounting point • In a location inside the engine compartment approved by NZTA for a specified vehicle or vehicle model • On the firewall or inner guards so it is visible from the front of the vehicle.
Forward-controlled vehicles (passenger vans and off-road vehicles)	<ul style="list-style-type: none"> • In the passenger compartment, on the top of the right-hand side wheel arch adjacent to the seat cushion • In the passenger compartment, on the inner panel of the right-hand A-pillar, adjacent to where the floor meets the A-pillar • In the passenger compartment on the B-pillar.
Goods vehicles and light omnibuses	<p>Vehicle with a separate chassis:</p> <ul style="list-style-type: none"> • On the outside of the chassis adjacent to the right front wheel arch, <p>Vehicle without a separate chassis:</p> <ul style="list-style-type: none"> • As specified for forward-controlled vehicles.

If the vehicle is unfamiliar, and the VIN or chassis number cannot be located, the vehicle inspector should contact the manufacturer’s agent or the local VIN issuing agent ([VTNZ](#), [VINZ](#), [NZAA](#), [Drivesure](#), [CVC](#), [i4Checkpoint](#)).

Figure 1-1-1. Structure of a VIN issued by the NZ Transport Agency



Post-29 November 2009



Figure 1-1-2. Structure of a VIN issued by the vehicle manufacturer



A26658 ← Vehicles unique number

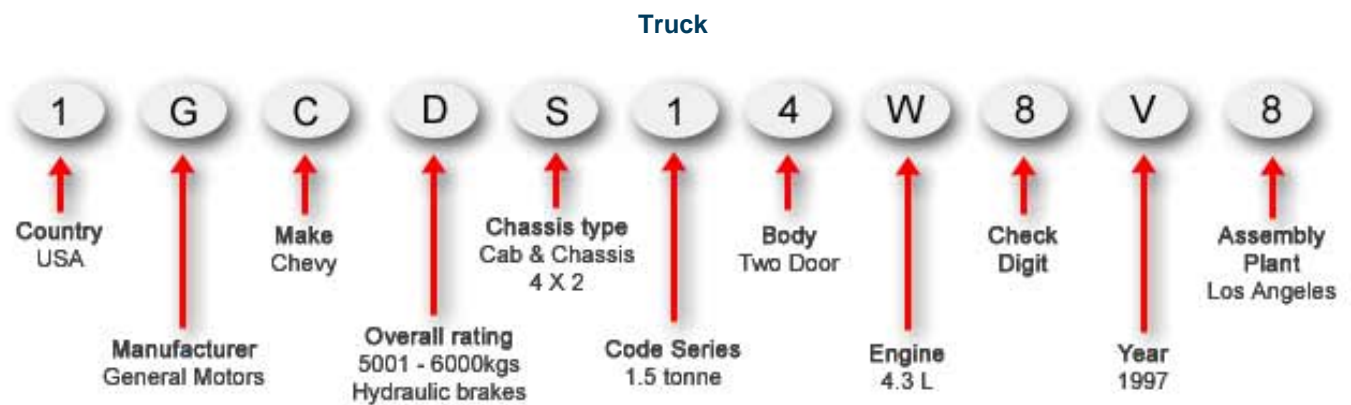

132166 ← Vehicles unique number

Summary of legislation

Applicable legislation

- [Land Transport Rule: Vehicle Standards Compliance 2002](#).

Mandatory requirements

1. A vehicle first registered or re-registered in New Zealand before 1 April 1994 must have a chassis number or VIN.
2. A vehicle first registered or re-registered in New Zealand from 1 April 1994 must have a VIN.

Condition

3. A VIN or chassis number must not have been removed, erased, altered, defaced, obscured, destroyed, obliterated or affixed unlawfully, or be unauthorised.

Page amended **1 October 2022** (see [amendment details](#)).

1-2 Vehicle details

Reasons for rejection

1. The number on the registration plate(s) is not the same as stated on the licence label.
2. The licence label does not correctly describe the vehicle
 - do not reject the vehicle if the label type is incorrect, eg 'B' or 'A'.
3. The Vehicle Inspection and Certification (VIC) or LATIS system does not correctly describe the vehicle.

Page added **1 October 2020** (see [amendment details](#))

Page updated 1 November 2024 (see [details](#))

2 Vehicle exterior

2-1 External projections

Reasons for rejection

Condition and performance

1. The risk of a component (Note 5) hooking a vehicle, or hooking or grazing a person, has not been minimised, eg a bonnet or bumper has been removed, exposing sharp, moving or hot components.
2. An ornamental object or fitting (Note 2) protrudes in such a way that it is likely to injure a person.
3. A protruding object or fitting that has a functional purpose (Note 3) is not installed so that the risk of causing injury to a person is minimised, eg the object or fitting:
 - a) is of excessively heavy construction for the purpose for which it has been fitted, or

- b) has sharp corners, or
 - c) slopes forward, unless this is necessary to fit the contours of the vehicle, or
 - d) has an unnecessarily wide gap between the object or fitting and the front of the vehicle, or
 - e) exceeds the vehicle's width by more than 100mm on either side, other than side mounted glass sheet transport racks and collapsible side mirrors, or
 - f) is a glass sheet transport rack that is not fitted with a front flaring to minimise the risk of injury to a person.
4. A protruding component, object or fitting is not securely attached to the vehicle.
5. A protruding object or fitting adversely affects the driver's vision or control.

Modifications

6. A modification (Note 4) affects an external projection – including a protruding object or fitting that has a functional purpose and affects the driver's vision or control of the vehicle, and
- a) is not excluded from the requirements for specialist certification (Table 2-1-1), and
 - b) is missing proof of specialist or accepted overseas certification, ie:
 - i. the vehicle is not fitted with a valid vehicle certification plate (eg low volume vehicle plate or heavy vehicle certification plate/label), or
 - ii. the operator is not able to produce a valid modification declaration or authority card
 - iii. the vehicle has not been certified to an accepted overseas system as described in [Technical bulletin 13](#)

Note 1

The external projections requirements relate to the design and maintenance of objects and fittings that protrude from the exterior of the motor vehicle with regard to the safety of other motor vehicles, pedestrians and cyclists. The attachment of such objects and fittings to the vehicle is addressed in the [Vehicle structure](#) section of this manual.

Note 2

Ornamental object or fitting means an object or fitting that does not have a practical purpose, eg bonnet emblems.

Note 3

Functional object or fitting means an object or fitting that has a practical purpose, eg panniers, pack racks, spare wheel carriers, and so on.

Note 4

Modify means to change a vehicle from its original state by altering, substituting, adding or removing any structure, system, component or equipment, but does not include repair.

Repair means to restore a damaged or worn vehicle, its structure, systems, components or equipment to within safe tolerance of its condition when manufactured, including replacement with equivalent undamaged or new structures, systems, components or equipment.

Note 5

Components include damaged, corroded and exposed body panels.

Note 6

The following vehicles with a GVM of 2500kg or less must comply with a frontal impact occupant protection standard:

- Class MA motor vehicles manufactured on or after 1 March 1999
- Class MA motor vehicles that were less than 20 years old when they were first registered in New Zealand on or after 1 April 2002
- Class MB and MC motor vehicles manufactured on or after 1 October 2003.

Note 7

Rear bumper removal must still meet external projection requirements.

Note 8

Heating, drilling, welding or cutting the vehicle structure, modifying a roof bow, or modifying any part of the structure anchorage would be considered to weaken the structure. Cutting a single layer of unstressed panel of sheet metal (ie roof) is not considered to weaken the vehicle structure. Drilling a hole suitable for a child restraint top tether does not require LVV certification.

Note 9

A pedestrian trap is any part of a vehicle that may hook, catch or pull/push a pedestrian into or under a vehicle. Vehicle components should be shaped to reduce injury to a pedestrian and to move the pedestrian away from the vehicle in the event of an incident.

Table 2-1-1. Modifications that do not require specialist certification

Fitting of or modification to:	Specialist certification is not required provided that:
<p>Body kits and components</p> <p>(including utility canopies, plastic bumper skins and bonnet projections)</p>	<ul style="list-style-type: none"> • the fitting system does not weaken the vehicle structure (Note 8), and • no frontal impact components have been removed where the vehicle is required to comply with a frontal impact occupant protection standard (Note 6) • the kit or components do not present any external projections that could cause injury, to the occupants or pedestrians, or present a snagging/hooks risk to a vehicle or person, and • the performance of any lamps is not affected as a result of the fitting of the kit or components, and • the driver’s vision has not been affected. <p>See also Table 3-1-1.</p>
<p>Side racks (for glass or other sheet materials)</p>	<ul style="list-style-type: none"> • there is no doubt as to the rack’s load carrying capacity, and • the rack is secured without weakening the vehicle structure (Note 8) and, • no forward-facing pedestrian traps exist (Note 9), and <ul style="list-style-type: none"> ◦ the rack is designed and protected so that sharp or dangerous cargo cannot face directly forward projecting beyond the outside of the body. <p>See also Table 3-1-1.</p>
<p>Bumper bar (removal and change) (Note 7)</p>	<ul style="list-style-type: none"> • the vehicle is not required to comply with a frontal impact occupant protection standard (Note 6), and • does not weaken the vehicle structure (see Note 8), and • any changes to the bumper do not affect the performance of mudguards, or • a rear bumper bar has been replaced by a towbar crossmember. <p>See also Table 3-1-1.</p>

<p>Auxiliary bars (including bull bars, nudge bars, external roll cages and A-frames [or similar])</p>	<ul style="list-style-type: none"> • the vehicle is not required to comply with a frontal impact occupant protection standard (Note 6) • the auxiliary bar: <ul style="list-style-type: none"> ◦ presents no pedestrian traps (Note 9), and ◦ is not angled forward except where necessary to clear the contours of the vehicle, and ◦ presents no sharp edges or an external radius of less than 3mm • the winch either: <ul style="list-style-type: none"> ◦ does not protrude forward of the front face of the bumper, or ◦ does project forward of the bumper line but is fitted with 'pedestrian-friendly' shrouds to reduce trapping risk and present a larger forward-facing surface area • the vehicle is required to comply with a frontal impact occupant protection standard and the auxiliary bar: <ul style="list-style-type: none"> ◦ is a vehicle manufacturer supplied component for that vehicle, or ◦ has been certified by the auxiliary bar manufacturer as frontal impact compliant (as may be indicated by a label). <p>Note that an auxiliary bar that does not meet the above minimum requirements is unlikely to meet LVV requirements and so cannot be certified.</p> <p>See also Table 3-1-1.</p>
<p>A-frames</p>	<ul style="list-style-type: none"> • the A-frame meets all of the following requirements: <ul style="list-style-type: none"> ◦ is attached to the chassis by means other than welding, and ◦ the components are fit for purpose, and ◦ the brackets remaining on the vehicle when the A-frame is removed are recessed behind the forward surface of the bumper by no less than 20mm, and ◦ the brackets are fitted so that they do not bridge the vehicle's crumple zones, and ◦ the brackets are fitted so that they do not significantly stiffen the front of the vehicle. <p>See also Table 3-1-1.</p>
<p>Bonnet emblems or badges</p>	<ul style="list-style-type: none"> • the emblem or badge is designed and attached in such a way that it will fold back or break off in the event of contact, without leaving any sharp edges, or • the emblem or badge has no sharp edges, and is fitted flat to the bonnet with a thickness no more than 10mm.
<p>Bonnet pins</p>	<ul style="list-style-type: none"> • the vehicle is not required to comply with a frontal impact occupant protection standard (Note 6); and <ul style="list-style-type: none"> ◦ the pins: <ul style="list-style-type: none"> ▪ have no sharp edges/are rounded with radius more than 3mm, and ▪ do not present any external projections that could cause injury, to the occupants or pedestrians, and ▪ do not present a snagging risk

Ute trays	<p>For vehicles first registered in New Zealand before 1 January 2021:</p> <ul style="list-style-type: none"> • in-service requirements <p>For vehicles first registered in New Zealand on or after 1 January 2021:</p> <ul style="list-style-type: none"> • the tray has no sharp edges and radiuses of not less than 3mm on every external edge, and • no forward-facing pedestrian traps exist (Note 2), and • the tray protrudes no more than 100mm from the widest part of the vehicle cab/body structure (excluding mirrors), or • the forwards edges of the tray are tapered rearwards at an angle of no less than 30 degrees from the tray's front edge or have an equivalent, or better, form of pedestrian protection. <p>See also Table 3-1-1.</p>
Fitting of or modification to:	Specialist certification is never required:
Aerials	<ul style="list-style-type: none"> • in-service requirements for conditions and performance must be met.
Roof-mounted solar panels	
Trunk racks	
Roof-mounted wheelchair winch	
Roof racks (except heavy PSVs)	
Additional or substituted rear-view mirrors	
Any modification for the purposes of law enforcement or the provision of emergency services	

Summary of legislation

Applicable legislation

- [Land Transport Rule: External Projections 2001](#).

Permitted equipment

1. A motor vehicle may be fitted with a protruding ornamental or functional object or fitting.

Condition and performance

2. A protruding ornamental object or fitting must not be likely to injure a person.
3. A protruding object or fitting that has a functional purpose must be installed so that the risk of the object or fitting causing injury to a person is minimised.
4. Components of a motor vehicle, including damaged or corroded body panels, must be such that the risk of their hooking a vehicle, or hooking or grazing a person, is minimised.
5. A protruding object or fitting must not adversely affect driver vision or driver control.

Modifications

6. A modification that affects an external projection must be inspected and certified by a specialist certifier, unless the vehicle:
 - a) is excluded from the requirement for specialist certification (Table 2-1-1), and
 - b) has been inspected in accordance with the requirements in this manual, including those for equipment, condition and performance.

Page amended **29 April 2020** (see [amendment details](#)).

2-2 Dimensions

Reasons for rejection

Mandatory equipment

1. A rigid vehicle (Note 1) with a GVM of 3500kg or less exceeds the dimension requirements set out in Table 2-2-1 and is not a vehicle operating on a valid permit, exemption or approval.
2. A rigid vehicle that exceeds the dimensions set out in Table 2-2-1 is not fitted with the appropriate hazard warning equipment set out in Table 2-2-2.

Note 1

A **rigid vehicle** means a vehicle with motive power, driver's position and steering system, that does not have any pivot points to allow any part of the vehicle chassis to move or rotate in relation to any other part of the vehicle chassis, but includes a pivot steer vehicle.

Note 2

The **rear axis of a vehicle** means:

- if the vehicle is fitted with one rear axle: the centre of that axle
- if the vehicle is fitted with a set of two axles: midway between those two axles if each axle has an equal number of tyres on it, or two-thirds of the distance from the lesser-tyred axle towards the greater-tyred axle, if one axle has twice as many tyres on it as the other axle.

Table 2-2-1. Dimension requirements (see Figure 2-2-1)

Dimension	Maximum distance	Comments
Width	2.55m 1.275m from each side of the longitudinal centreline	Measurement does not include: <ul style="list-style-type: none"> • collapsible mirrors which extend no more than 240mm from the side and 1.49m when measured from the vehicle's longitudinal centre line • direction indicators and side-marker lamps • cab exterior grab rails that extend no more than 1.325m when measured from a vehicle's longitudinal centre-line • the bulge towards the bottom of a tyre • cameras or close-proximity monitoring systems mounted on the side exterior of a vehicle that extends not more than 70mm from the side wall of the vehicle • devices for improving the aerodynamic performance of a vehicle that extend not more than 25mm from either side of a vehicle.
Overall length	12.6m (no tow coupling fitted) 11.5m (tow coupling fitted)	Measurement does not include collapsible mirrors.
Height	4.3m	
Forward distance	9.5m (no tow coupling fitted) 8.5m (including tow coupling if fitted)	Forward distance is measured from the rear axis (Note 2) to the front of the vehicle or its load whichever is foremost. Measurement does not include collapsible mirrors.
Rear overhang	4m	Rear overhang is measured from the rear axis (Note 2) to the rear of the vehicle or its load whichever is the greater.
Front overhang	3m	Front overhang is measured from the front edge of the driver's seat in the rearmost position to the front of the vehicle.

Dimension	Maximum distance	Comments
Articulated vehicle point of attachment	No further rearward than the centre of the rear axle (where the rear axle consists of only one axle) No further than 300mm rearward of the rear axis (where the rear axle set consists of more than one axle)	Example: Fifth wheel fitted to a truck to tow a semi-trailer caravan

Table 2-2-4. Hazard warning equipment requirements for vehicles that exceed the dimensions in Table 2-2-3

(see Figure 2-2-3 for vehicle category thresholds) (Note 6)

Vehicle category (see Figure 2-2-3)	Dimension	Limits (up to and including)	Required hazard warning equipment
Category 1	Width/forward distance	2.55m /11.4m, or 3.1m/10.5m, or 3.7m/8.5m, or	1. Flags ¹ or panels ² fitted on each side at the front and rear as close as practical to the outside edge (for alternative requirements for a mobile crane see (Note 7)) 2. OVERSIZE sign ³ fitted at the front and rear if more than 3.1m wide
	Length	25m, or	
	Front overhang	7m, or	
	Rear overhang	7m	
Category 2 (not including category 1)	Width/forward distance	2.55m /13.3m, or 4.5m/8.5m, or	1. Panels ² fitted on each side at the front and rear as close as practical to the outside edge (for alternative requirements for a mobile crane see (Note 7)) 2. OVERSIZE sign ³ fitted at the front and rear if more than 3.1m wide 3. Amber beacon fitted so that it is visible to approaching traffic if the vehicle is more than 3.7m wide
	Length	35m, or	
	Front overhang	10m, or	
	Rear overhang	10m	
Category 3 (not including category 2)	Width/forward distance	2.55m /20m 5m/20m 5m/8.5m	1. Panels ² fitted on each side at the front and rear as close as practical to the outside edge (for alternative requirements for a mobile crane see (Note 7)) 2. OVERSIZE sign ³ fitted at the front and rear 3. Amber beacon fitted so that it is visible to approaching traffic if the vehicle is more than 3.7m wide
	Front overhang	10m, or	

Vehicle category (see Figure 2-2-3)	Dimension	Limits (up to and including)	Required hazard warning equipment
Rear overhang	10m		
Category 4A (not including category 3)	Width/forward distance	11m/20m 11m/8.5m	1. Panels ² fitted on each side at the front and rear as close as practical to the outside edge (for alternative requirements for a mobile crane see (Note 7)) 2. OVERSIZE sign ³ fitted at the front and rear 3. Amber beacon fitted so that it is visible to approaching traffic if the vehicle is more than 3.7m wide
	Front overhang	10m, or	
	Rear overhang	10m	
Category 4B	Exceeding any limit in Category 4A		1. Panels ² fitted on each side at the front and rear as close as practical to the outside edge 2. OVERSIZE sign ³ fitted at the front and rear 3. Revolving amber beacon fitted so that it is visible to approaching traffic if the vehicle is more than 3.7m wide

¹ Flags:

- must be fluorescent yellow
- must be at least 400mm long x 300mm wide.

² Hazard warning panels:

- must be reflective yellow-green with a reflective orange diagonal stripe
- comply with AS/NZS 1906.1:2007
- be frangible for those portions which extend beyond the vehicle's limits (frangible means breakable or readily deformable)
- must be of at least the minimum dimensions and the colours specified in Figure 2-2-2.

³ OVERSIZE sign:

- must be black lettering on a yellow-green background
- must be at least 300mm x 1100mm in size
- be frangible if any part of the sign extends beyond the body or load of the vehicle, whichever it is attached to (frangible means breakable or readily deformable)
- may be in two parts: OVER and SIZE.

Figure 2-2-1. Dimension requirements

(Note: Dimensions in red updated in VDAM 2016)

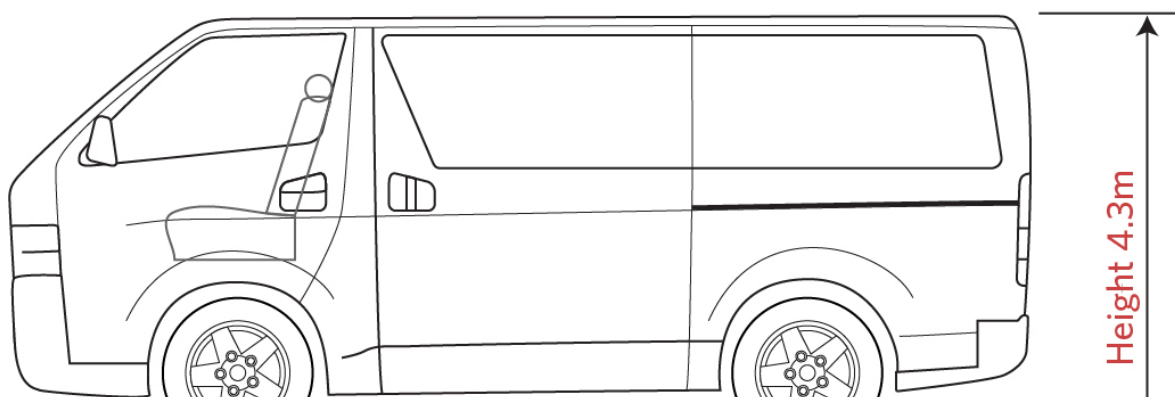
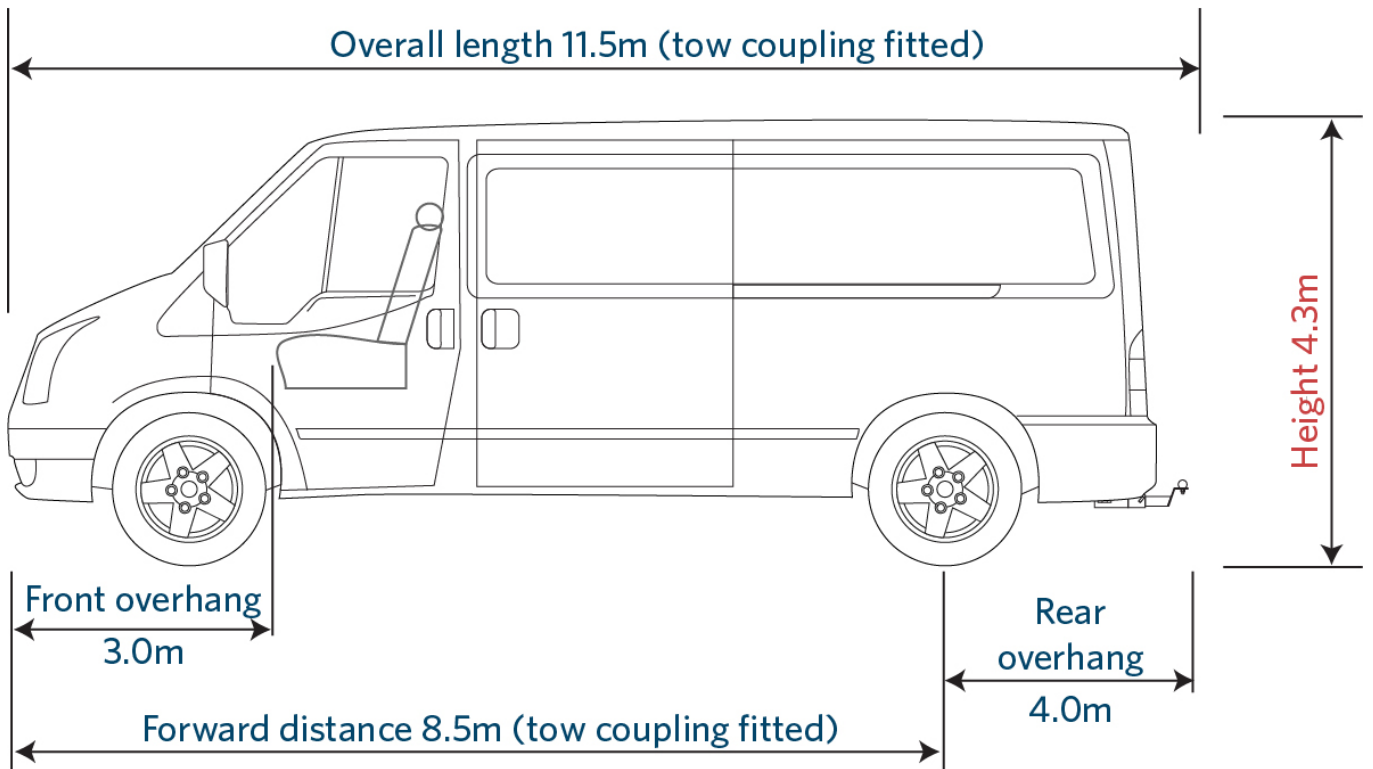
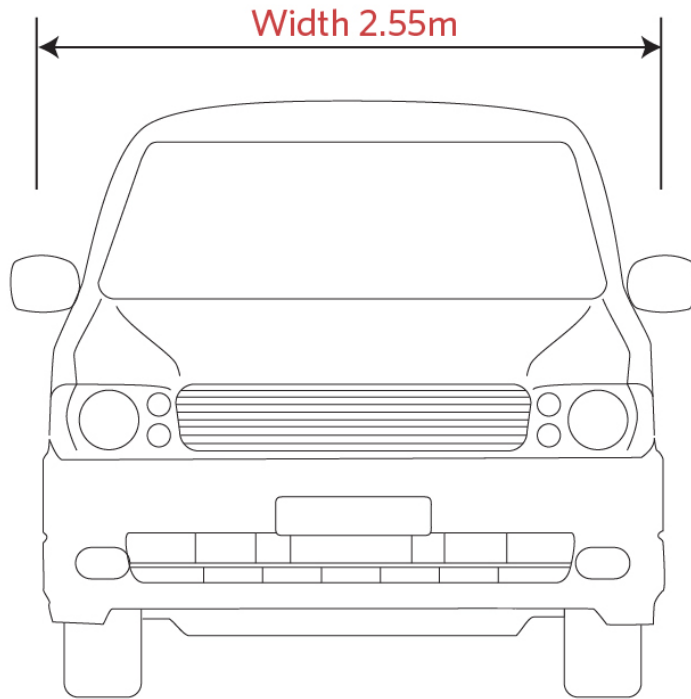
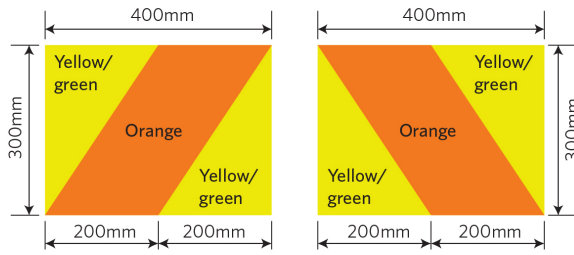
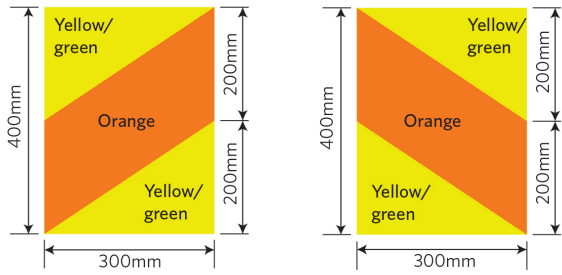

Figure 2-2-2. Hazard panel details

Display these panels



or these panels



or these panels

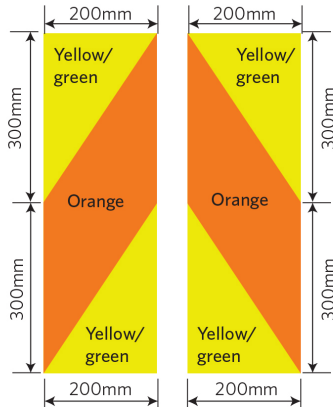

Figure 2-2-3. Hazard panel location and orientation

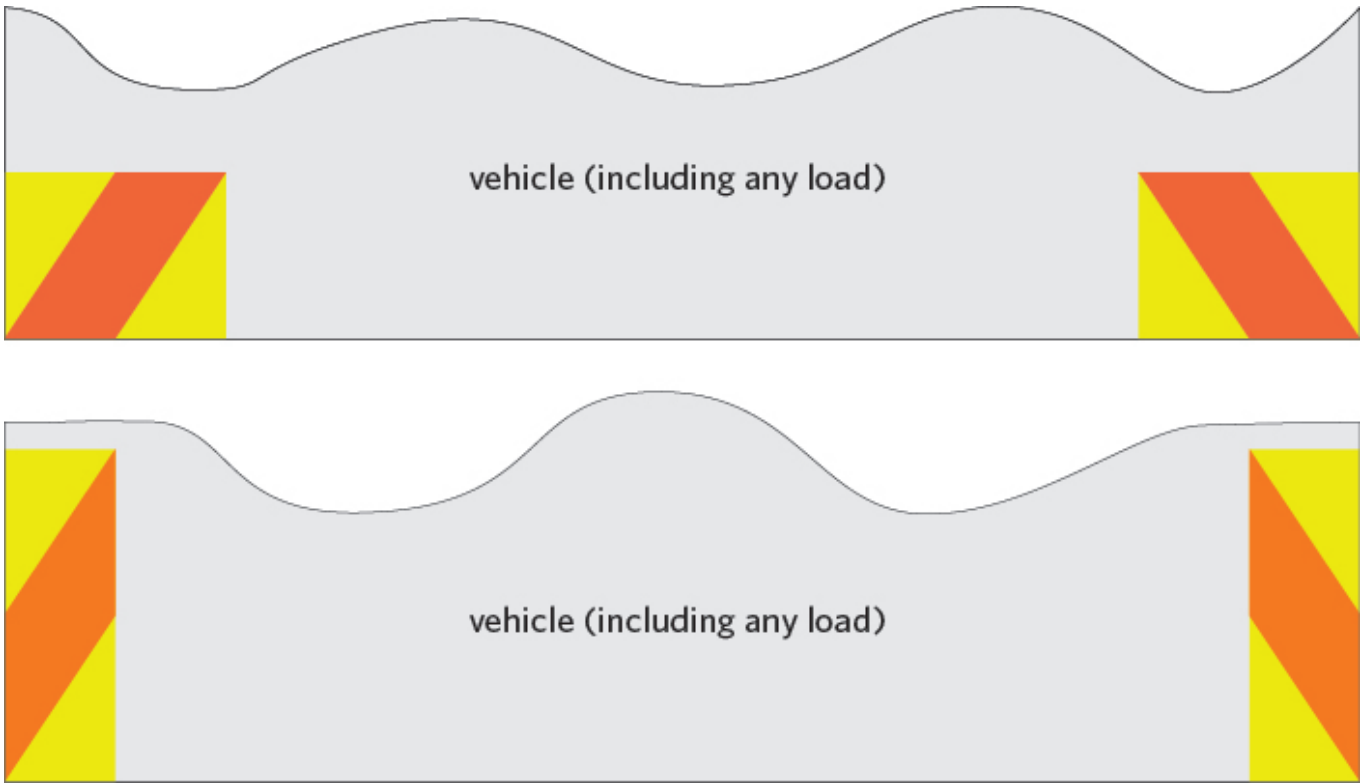
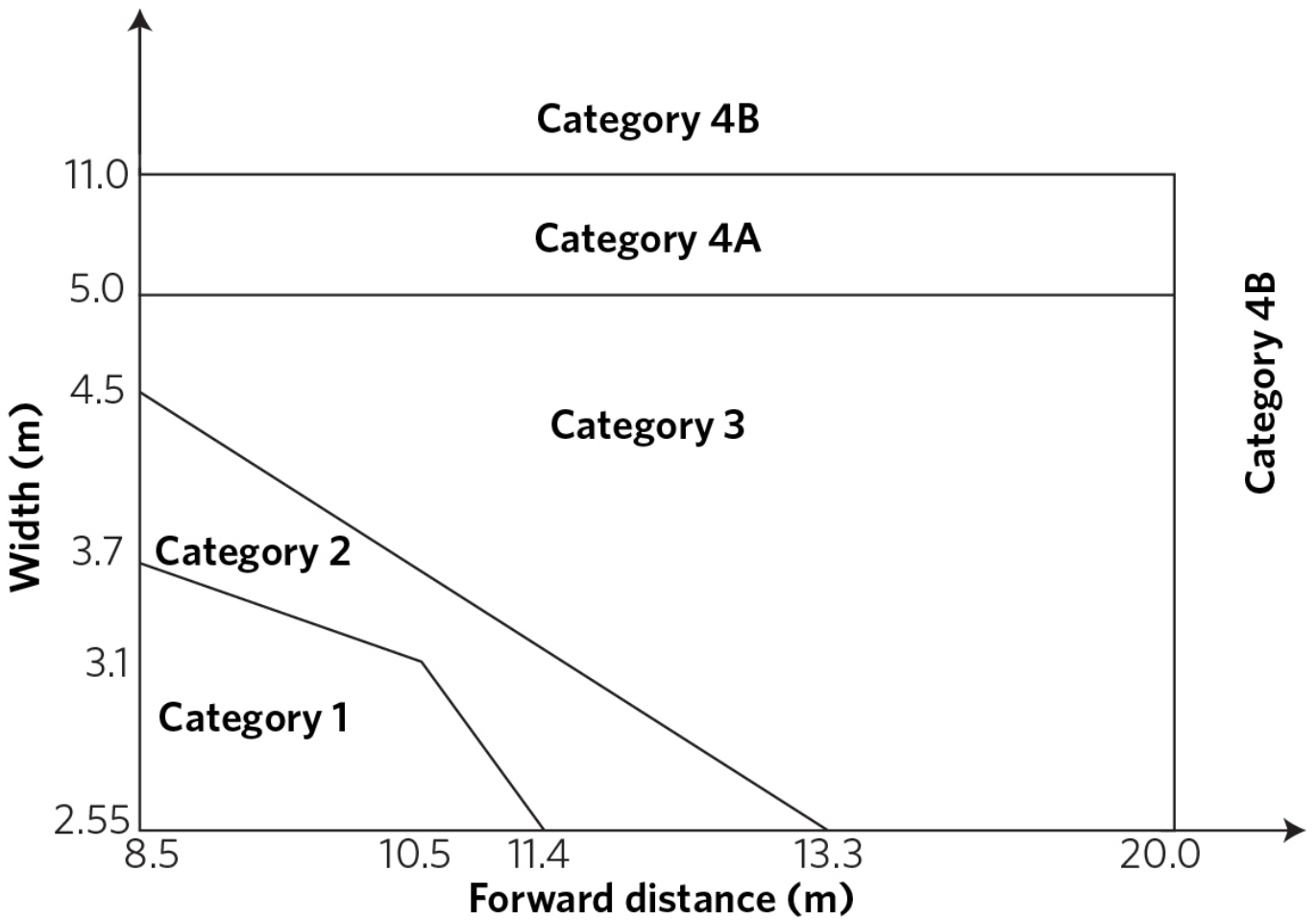

Figure 2-2-4. Vehicle categories and width/forward-distance thresholds



Use this figure to determine vehicle category in Table 2-2-2.

For the purposes of this figure, vehicles with a width less than 2.55m are deemed to have a width of 2.55m and vehicles with a forward distance of less than 8.5m are deemed to have a forward distance of 8.5m.

Summary of legislation

Applicable legislation

- [Land Transport Rule: Vehicle Dimensions and Mass 2016](#).

Mandatory equipment

1. A rigid vehicle, or an articulated bus, with a GVM of 3500kg or less that exceeds the dimensions in Table 2-2-1 must meet the requirements in Table 2-2-2.
2. A vehicle may exceed the dimensions in Table 2-2-3 only if it is a vehicle operating on a valid permit, exemption or approval.

Page amended **1 June 2019** (see [amendment details](#)).

3 Vehicle structure

3-1 Structure

Reasons for rejection

Mandatory equipment

1. An open-bodied vehicle that entered service as a PSV in New Zealand on or after 1 January 2001:
 - a) has side walls that are less than 450mm above the highest point of the uncompressed seat cushion on the open-bodied part of the vehicle, or
 - b) does not have a permanent framework in addition to the side walls to provide reasonable protection for the occupants in the case of the vehicle rolling over, or
 - c) on any upper deck does not have any drains to prevent water from collecting on it or draining into the body of the vehicle.

Condition

2. Refer to [general vehicle pages](#).
3. The structural strength of a PSV has been reduced so that it does not provide reasonable protection for the occupants in the event of roof or wall deformation resulting from the vehicle rolling over, eg:
 - a) structural parts of the superstructure have been removed or substituted with parts that are of insufficient strength or not fit for purpose.
4. A body to chassis attachment, such as a weld, or fastener is:
 - a) missing, or
 - b) loose, or

- c) cracked, or
- d) broken, or
- e) significantly corroded, or
- f) otherwise in poor condition.

Modification

5. Refer to [general vehicle pages](#).

Summary of legislation

Applicable legislation

- [Land Transport Rule: Passenger Service Vehicles 1999](#).

Mandatory equipment

1. An open-bodied vehicle that entered service as a PSV in New Zealand on or after 1 January 2001 must:
 - a) on the open-bodied part of the vehicle have side walls that extend at least 450 mm above the highest point of the uncompressed seat cushion, and
 - b) have a permanent framework to provide reasonable protection for the occupants in the case of the vehicle rolling over, and
 - c) on any upper deck have drains to prevent water from collecting on it or draining into the body of the vehicle.

Condition

2. Refer to [general vehicle pages](#).
3. The structural strength must be maintained throughout the service life of the PSV.
4. The superstructure must be of robust design, and made of materials fit for the purpose.
5. The body of a PSV must be fit for its purpose and securely fixed to the chassis.
6. The structural strength of a PSV must be sufficient to provide reasonable protection for the occupants in the event of roof or wall deformation resulting from the vehicle rolling over.

Modification

7. Refer to [general vehicle pages](#).
8. A modification that affects the vehicle structure must be inspected and certified by an LVV specialist certifier.

3-2 Stability

Reasons for rejection

Modification

1. A modification from 1 July 2000 affects the vehicle stability and:

- a) is not excluded from the requirements for LVV certification (Table 3-2-1), or
- b) is not for the purpose of law enforcement or the provision of emergency services, or
- c) is missing proof of LVV certification, that is the vehicle is not fitted with a valid low volume vehicle certification plate, **or**
- d) is missing proof of certification from an accepted overseas system as described in [Technical bulletin 13](#).

Table 3-2-1. Requirements for LVV certification

LVV certification is required	LVV certification is not required
1. Fitting of components to the roof, eg an air conditioning unit. 2. Changes in floor height or geometry, eg due to changes to suspension, wheel or tyre size.	1. Fitting of a roof rack 2. Any modification not listed in the left-hand column unless the vehicle inspector considers that certification is required because the modification or repair has affected the vehicle's safety performance (a second opinion from an expert may be needed).

Summary of legislation

Applicable legislation

- [Land Transport Rule: Passenger Service Vehicles 1999](#)
- [Land Transport Rule: Vehicle Standards Compliance 2002](#).

Modification

1. A modification, on or after 1 July 2000, that affects the stability of a light PSV must be inspected and certified by an LVV specialist certifier, unless the vehicle:

- a) is excluded from the requirements for LVV specialist certification (Table 3-2-1), and
- b) has been inspected in accordance with the requirements in this manual, including those for equipment, condition and performance.

Page amended **1 December 2016** (see [amendment details](#)).

4 Lighting

4-1 Headlamps

Reasons for rejection

Mandatory and permitted equipment

1. A vehicle other than class LE is not fitted with one pair of dipped-beam headlamps.
2. A vehicle other than class LE is fitted with more than:

- a) one pair of dipped-beam headlamps (Note 10) , or
 - b) two pairs of dipped-beam headlamps if the vehicle was first registered anywhere between 1 January 1977 and 31 March 1980, or
 - c) two pairs of main-beam headlamps.
3. A vehicle other than class LE is fitted with a headlamp that is not in a pair.
4. A vehicle of class LE is not fitted with one dipped-beam headlamp.
5. A vehicle of class LE is fitted with more than:
- a) two dipped-beam headlamps, or
 - b) two main-beam headlamps.
6. A vehicle (eg a vintage or veteran vehicle) does not meet standard headlamp requirements, and:
- a) does not have a valid vehicle identity card with a lighting equipment endorsement, or
 - b) does not meet the conditions of the lighting equipment endorsement in its vehicle identity card.
7. A device that allows the headlamps to flash alternately is fitted to a vehicle that is not an emergency vehicle or a pilot vehicle.
8. A vehicle is fitted with a dipped-beam headlamp where the maximum intensity of the beam is projected to the right.

Condition

(see Note 5)

9. A lamp is insecure, obscured, or contains dirt or moisture in the form of large droplets, runs or puddles.
10. A lens is missing, or has a hole, crack or other damage that allows moisture or dirt to enter.
11. A lens or reflector is damaged or has deteriorated so that light output is reduced.
12. A main-beam headlamp warning device is obscured from the driver's vision.

Performance

13. When switched on, a headlamp emits a light that is:
- a) not substantially white or amber, or
 - b) not approximately equal in colour or intensity from the other lamp in a pair, or
 - c) not steady, or
 - d) not bright enough to illuminate the road ahead, eg due to modification, deterioration or an incorrect light source, or
 - e) too bright, eg due to the fitment of an HID or LED conversion kit (Note 8) or other incorrect light source (see also reason for rejection 19 below).
14. When the dipped-beam headlamps are switched on (with wheels pointing straight ahead):
- a) a lamp does not operate, or
 - b) more than two lamps operate on dipped beam, or

- c) more than four lamps operate on dipped beam on a vehicle first registered anywhere between 1 January 1977 and 31 March 1980, or
- d) the light beam produces an incorrect beam pattern, is not focused, or is reduced or altered, or
- e) the centreline of the light beam is too far to the left or slopes down too far so that the headlamp is no longer capable of illuminating the road at least 50m ahead (Figure 4-1-2), or
- f) the centreline of the light beam projects to the right of the vehicle's centreline, or projects from the lamp at an angle other than:
 - i. as specified by the vehicle or lamp manufacturer, or
 - ii. as specified in Table 4-1-1.

15. When the main-beam headlamps are switched on (with wheels pointing straight ahead):

- a) a lamp does not operate, or
- b) more than two lamps operate on main beam on a class LE vehicle, or
- c) more than four lamps operate on main beam on a vehicle of group M or N, or
- d) a vehicle first registered anywhere between 1 February 1977 and 31 March 1980 has a second pair of dipped-beam headlamps that continue to operate, or
- e) the centreline of the light beam projects to the right of the vehicle's centreline or up from the horizontal, or
- f) the light beam produces an incorrect beam pattern, is not focused or is reduced or altered, or
- g) the lamps are not capable of being switched to dipped beam or turned off from the driver's seating position, or
- h) a main-beam headlamp warning device, if fitted as original equipment, does not indicate to the driver that the main-beam headlamps are switched on.

16. A device fitted to a vehicle that allows the headlamps to flash alternately:

- a) does not indicate to the driver that the device is activated, or
- b) flashes:
 - i. faster than two flashes per second, or
 - ii. slower than one flash per second, or
 - iii. at a varying frequency.

17. Where a headlamp comprises an array of light sources (eg LEDs) fewer than 75% of these operate.

Modifications

18. An overlay has been applied that reduces or distorts the light emitted from the lamp (eg a tinted cover).

19. A headlamp is retrofitted with a type of light source other than that specified by the vehicle manufacturer or the headlamp manufacturer (eg a headlamp designed for a halogen bulb is fitted with any other type of light source such as an HID or LED bulb, or any other light source such as LED strips or non-OEM angel eyes) (Note 8).

20. Retrofitted headlamps are not fitted:

- a) as a pair, or
- b) symmetrically, or

c) as far towards each side of the vehicle as is practicable.

21. A retrofitted dipped-beam headlamp on a vehicle with a GVM of 12,000 kg or less is positioned at a height exceeding 1.2m from the ground (Note 9).

Note 1

An **original equipment (OE) lamp** is one that is fitted by the vehicle manufacturer in the original position, or is an equivalent replacement or aftermarket lamp suitable for the position provided by the vehicle manufacturer for that lamp. All other lamps are considered retrofitted (ie non-OE).

Note 2

If the dipped-beam headlamps are able to be adjusted from the driver's seating position, the alignment must be checked with the adjustment at its highest position.

Note 3

If the vehicle is fitted with self-levelling suspension, the alignment must be checked with the suspension at its normal level.

Note 4

Modify means to change a vehicle from its original state by altering, substituting, adding or removing a structure, system, component or equipment, but does not include repair.

Repair means to restore a damaged or worn vehicle, its structure, systems, components or equipment to within safe tolerance of its condition when manufactured, including replacement with undamaged or new structures, systems, components or equipment.

Headlamp means a lamp designed to illuminate the road ahead of a vehicle, and that is a:

- a) dipped-beam headlamp (single lamp), or
- b) main-beam (high-beam) headlamp (single lamp), and includes a driving lamp, or
- c) combination of a dipped-beam headlamp and a main-beam headlamp (dual-lamp unit).

Dipped-beam headlamp means a headlamp that is designed to emit a dipped beam, which is a beam of light that is angled downwards in such a way that it prevents undue dazzle or discomfort to oncoming drivers and other road users.

Main-beam headlamp means a headlamp that is designed to illuminate the road over a long distance ahead of the vehicle.

Note 5

If a headlamp is fitted with a readily removable cover, other than a clear protective cover, this must be removed for inspection of the headlamp.

Note 6

A vehicle originally manufactured with a headlamp arrangement that differs from what is required or permitted in this section may retain the original headlamps provided they remain fitted in their original position and perform as intended

by the vehicle manufacturer.

Note 7

A forward-facing permitted lamp that does not comply with the equipment, condition and performance requirements must be made to comply or be removed from the vehicle.

Note 8

A high-intensity discharge (HID or Xenon HID) or LED conversion kit consists of an HID or LED bulb which fits into the original headlamp unit in place of the original bulb with no change to the headlamp lens, reflector or housing.

It is illegal to fit an HID or LED conversion kit to a vehicle as it brings the headlamp out of standards compliance by producing poor beam patterns and light that is often far too bright to be safe. The bulbs can also produce light that is noticeably blue and not the required substantially white or amber colour. Vehicle and headlamp manufacturers do not permit this modification, and these kits cannot be LVV certified.

It is permitted to replace a complete halogen headlamp unit with a complete HID or LED headlamp unit. If the vehicle is required to meet an approved safety standard for headlamps, only approved headlamps can be retrofitted (see Figure 4-1-1).

Note 9

The dipped-beam headlamps may be positioned at a height exceeding 1.2m if a road maintenance implement (eg, snowplough or roadsweeper) fitted to the front of the vehicle would obscure headlamps placed at a height of 1.2m or less.

Note 10

It is acceptable for a pair of dipped-beam headlamps to consist of one symmetric and one asymmetric dipped-beam headlamp. However, in some cases this may result in one lamp being noticeably brighter than the other lamp in the pair. In that case, the vehicle inspector may determine that the dipped beams differ noticeably in light intensity, and the lamps fail the inspection. Note that a beamsetter's luxmeter cannot measure the light intensity of a dipped beam headlamp.

Table 4-1-1. Allowable dipped-beam headlamp alignment

	Headlamp type	Distance from ground to centre of light source	Dip rate of beam centre: lower and upper limits		
			Percent (%)	mm/3 m	Degrees (°)
EITHER	Any headlamp dipped beam	N/A	That specified by the vehicle or headlamp manufacturer		
OR	Headlamp with an older style symmetric dipped-beam pattern (see Figure 4-1-2)	N/A	3.0–3.5	90–105	1.7–2.0
OR	Headlamp with a modern symmetric or asymmetric dipped-beam pattern and distance from ground to centre of light source (see Figure 4-1-2)	less than 0.8 m	1.0–1.5	30–45	0.57–0.85
		0.8–1.2 m	1.0–2.0	30–60	0.57–1.15
		more than 1.2 m	2.0–2.5	60–75	1.15–1.43

Table 4-1-2. Dipped-beam angle conversions

Percent (%)	mm/3 m	Degrees (°)
1.0	30	0.6
1.1	33	0.6
1.2	36	0.7
1.3	39	0.7
1.4	42	0.8
1.5	45	0.9
1.6	48	0.9
1.7	51	1.0
1.8	54	1.0
1.9	57	1.1
2.0	60	1.1
2.1	63	1.2
2.2	66	1.3
2.3	69	1.3
2.4	72	1.4
2.5	75	1.4
2.6	78	1.5
2.7	81	1.5

Percent (%)	mm/3 m	Degrees (°)
2.8	84	1.6
2.9	87	1.7
3.0	90	1.7
3.1	93	1.8
3.2	96	1.8
3.3	99	1.9
3.4	102	1.9
3.5	105	2.0

Figure 4-1-1. Approved headlamp standard markings

The following standard markings may assist in determining compliance with approved standards.

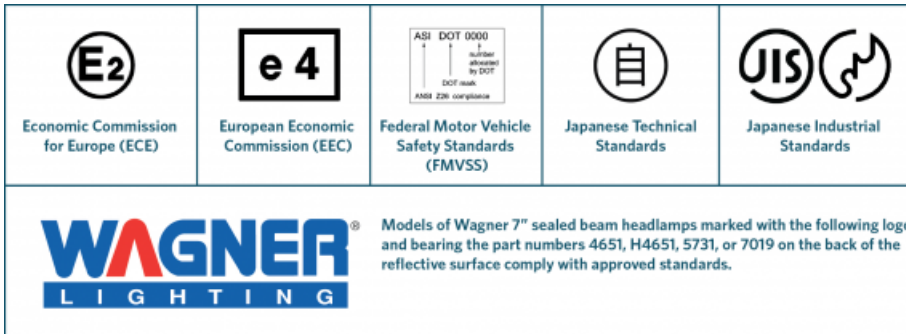

Vehicles required to comply with an approved headlamp standard are:

- vehicles of class MA and NA manufactured on or after 1 January 1992
- vehicles of class MB, MC, MD1, MD2, MD3, MD4, ME, NB and NC manufactured on or after 1 January 1996.

Figure 4-1-2. Minimum illuminated area

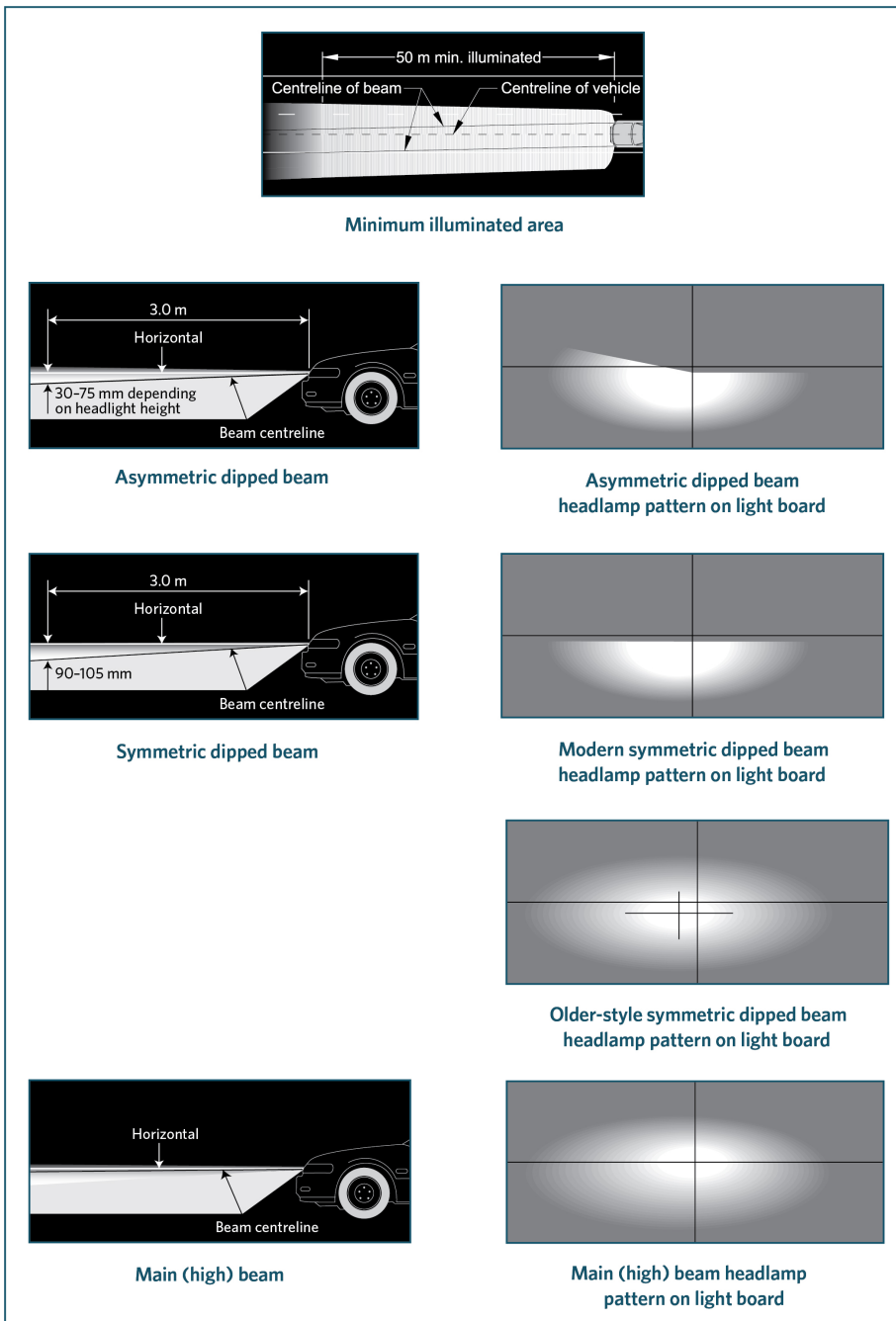

Summary of legislation

Applicable legislation

- [Land Transport Rule: Vehicle Lighting 2004](#)
- New Zealand Gazette, 28 August 1980, issue 103, page 2569.

Mandatory and permitted equipment

1. A vehicle other than of class LE:

- a) must be fitted with one pair of dipped-beam headlamps, and

- b) may be fitted with one or two pairs of main-beam headlamps.
2. A vehicle of class LE:
- a) must be fitted with one or two dipped-beam headlamps, and
 - b) may be fitted with one or two main-beam headlamps.
3. A vehicle first registered anywhere between 1 February 1977 and 31 March 1980 may be fitted with a second pair of dipped-beam headlamps that:
- a) do not operate when the main-beam headlamps are switched on, and
 - b) may operate independently of the first pair of dipped-beam headlamps.
4. A vehicle (eg a vintage or veteran vehicle) manufactured without lamps, or with lamps that cannot meet specified requirements, may obtain a WoF if:
- a) the vehicle has a valid vehicle identity card with a lighting equipment endorsement, and
 - b) the vehicle meets the conditions of that endorsement.
5. A vehicle required to meet an approved safety standard for lighting must continue to meet an approved safety standard for lighting.
6. A retrofitted dipped-beam headlamp on a vehicle with a GVM of 12,000 kg or less must be fitted at a height not exceeding 1.2 m from the ground (Note 9).
7. A warning device may be fitted that indicates that the main-beam headlamps are switched on.
8. An emergency vehicle or a pilot vehicle may be fitted with a device that allows the headlamps to flash alternately, provided it is also fitted with equipment that indicates to the driver that the device is activated.
9. A retrofitted pair of headlamps must be symmetrically mounted as far towards each side of the vehicle as is practicable.

Prohibited equipment

10. A dipped-beam headlamp designed solely for a left-hand drive vehicle, where the maximum intensity of the beam is dispersed to the right, must not be fitted.

Condition (Note 5)

11. A headlamp must:
- a) be in sound condition, and
 - b) not be obscured.

Performance

12. A headlamp must operate in a way that is appropriate for the lamp and the vehicle.
13. A headlamp must emit a steady light.
14. A headlamp must provide sufficient illumination and light output to illuminate the road ahead.
15. If fitted with a device that allows headlamps to flash alternately, the lamps must flash at a fixed frequency.
16. A pair of headlamps must emit light that is approximately of equal colour and intensity when switched on.
17. A headlamp must emit a beam that is substantially white or amber.

18. A main-beam headlamp must be capable of being dipped or turned off from the driver's position.
19. A warning device that indicates that the main-beam lamps are in operation must be in good working order.
20. When the headlamps are switched on and the vehicle's front wheels are pointing in the straight-ahead position:
 - a) the centre of a headlamp beam must be either parallel to or to the left of the longitudinal centreline of the vehicle, and
 - b) the centre of a main-beam headlamp beam must be either parallel to or dipping down from the horizontal, and
 - c) the centre of a dipped-beam headlamp beam must dip at an angle specified by the vehicle or lamp manufacturer, or:
 - i. 3–3.5% for a symmetric beam pattern, or
 - ii. 1–1.5% for an asymmetric beam pattern where the centre of the light source is less than 0.8 m from the ground, or
 - iii. 1–2% for an asymmetric beam pattern where the centre of the light source is 0.8–1.2 m from the ground, or
 - iv. 2–2.5% for an asymmetric beam pattern where the centre of the light source is above 1.2 m from the ground.
21. The dipped-beam headlamps must illuminate the road ahead for 50 m in normal darkness.
22. Where a headlamp comprises an array of light sources (eg LEDs), at least 75% of these must operate.
23. A device fitted to a vehicle that allows the headlamps to flash must:
 - a) make the headlamps flash alternately at a frequency of 1–2 Hertz, and
 - b) incorporate equipment that indicates to the driver that the device is activated.
24. A headlamp must be fitted with a light source that is specified by the vehicle manufacturer or the headlamp manufacturer.

Modifications (Note 4)

25. A headlamp that is affected by a modification must meet equipment, condition and performance requirements.

Page amended **1 April 2021** (see [amendment details](#)).

4-2 Front and rear fog lamps

Reasons for rejection

Permitted equipment

1. A group M or N vehicle is fitted with:
 - a) only one front fog lamp, or
 - b) more than one pair of front fog lamps.
2. A vehicle of class LE is fitted with more than two front fog lamps.
3. A vehicle is fitted with more than two rear fog lamps.

4. A retrofitted pair of fog lamps is not fitted:

- a) symmetrically, or
- b) as far towards each side of the vehicle as is practicable, or
- c) positioned higher than the dipped-beam headlamps.

Condition

(see Note 3)

- 5. A lamp is insecure or contains moisture in the form of large droplets, runs or puddles .
- 6. A lens is missing, or has a hole, crack or other damage that allows moisture or dirt to enter.
- 7. A reflector is damaged or has deteriorated so that light output is reduced.
- 8. A fog lamp warning device, if fitted, is obscured from the driver's vision.

Performance

9. When switched on, a front fog lamp does not operate (Note 5).

10. When switched on, a front fog lamp emits light that:

- a) is not projected to the front, or
- b) produces an incorrect beam pattern (Figure 4-2-1), or
- c) is not substantially white or amber to the front, or
- d) is not approximately equal in colour or intensity from the other lamp in the pair, or
- e) is not steady, or
- f) is not bright enough to illuminate the road ahead in conditions of severely reduced visibility, eg due to modification, deterioration, dirt or an incorrect light source, or
- g) is too bright, and could dazzle other road users, eg due to the fitment of an HID or LED conversion kit (Note 6) or other incorrect light source , or
- h) is altered, eg due to damage or modification, or
- i) has a beam centre to the right of the vehicle's centreline, or
- j) has a beam that is not permanently dipped, or
- k) has a beam centre that dips at an angle of less than 3% (Figure 4-2-1).

11. When switched on, a rear fog lamp emits light that is:

- a) not projected to the rear, or
- b) not diffuse, or
- c) not substantially red, or
- d) not approximately equal in colour or intensity from the other lamp in a pair, or
- e) of variable intensity, or
- f) not bright enough to indicate the presence of the vehicle from the rear in conditions of severely reduced visibility, eg due to modification, deterioration or an incorrect light source, or

g) altered, eg due to damage or modification.

12. A fog lamp cannot be switched off from the driver's seating position.

13. Where a fog lamp comprises an array of light sources (eg LEDs), fewer than 75% of these operate.

14. A fog lamp warning device, if fitted, does not operate.

Note 1

Fog lamp means a high-intensity front or rear lamp designed to aid the driver or other road users in conditions of severely reduced visibility, including fog or snow, but not including clear atmospheric conditions under the hours of darkness.

Note 2

A rear fog lamp that does not comply with equipment, condition and performance requirements must be made to comply or be disabled so that it does not emit a light.

Note 3

If a front fog lamp is fitted with a readily removable cover, other than a clear protective cover, this must be removed for inspection of the fog lamp.

Note 4

A vehicle originally manufactured with a front- or rear-fog-lamp arrangement that differs from what is required or permitted in this section may retain the original front or rear fog lamps provided they remain fitted in their original position and perform as intended by the vehicle manufacturer.

Note 5

A forward-facing permitted lamp that does not comply with the equipment, condition and performance requirements must be made to comply, be removed from the vehicle, or be disabled so that it does not emit a light.

Note 6

A high-intensity discharge (HID or Xenon HID) **or LED** conversion kit consists of an HID **or LED** bulb which fits into the original **fog lamp** unit in place of the original bulb with no change to the lens, reflector or housing.

It is illegal to fit an HID **or LED** conversion kit to a vehicle as it brings the **fog lamp out of specification** by producing poor beam patterns and light that is **often** far too bright to be safe. The bulbs can also produce light that is noticeably blue and not the required substantially white or amber colour. **Fog lamp** manufacturers do not permit this modification, and these kits cannot be LVV certified.

It is permitted to replace a complete halogen **fog lamp** unit with a complete HID **or LED fog lamp** unit.

Figure 4-2-1. Front fog lamp characteristics

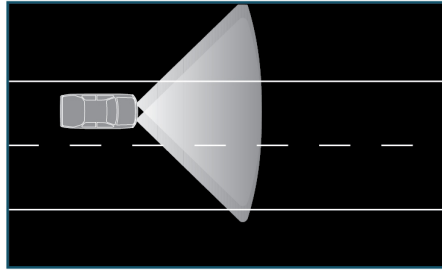

(a) Pattern on the road

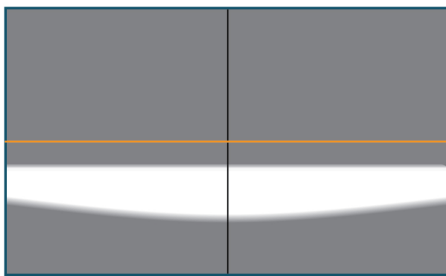

(b) Pattern on light board

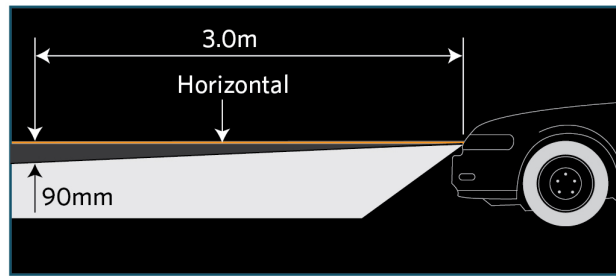

(c) Beam dip angle

Summary of legislation

Applicable legislation

- [Land Transport Rule: Vehicle Lighting 2004](#).

Permitted equipment

1. A vehicle other than class LE: one pair of front fog lamps.
2. A vehicle of class LE: one or two front fog lamps.
3. One or two rear fog lamps.
4. A retrofitted pair of fog lamps must be symmetrically mounted as far as is practicable towards each side of the vehicle.
5. A retrofitted front fog lamp must not be positioned higher than the dipped-beam headlamps.
6. A vehicle may be fitted with a warning device that indicates that a front or rear fog lamp is in operation.

Condition

7. A front fog lamp must be in sound condition.
8. A rear fog lamp must be in sound condition if it emits a light.

Performance

9. A fog lamp must operate in a way that is appropriate for the lamp and the vehicle.
10. A fog lamp must emit a steady light.

11. A front fog lamp must provide sufficient light output to illuminate the road ahead in conditions of severely reduced visibility.
12. A rear fog lamp must provide sufficient light output to indicate the presence of the vehicle on the road in conditions of severely reduced visibility.
13. The light emitted from a front fog lamp must be substantially white or amber.
14. The light emitted from a rear fog lamp must be diffuse and substantially red in colour.
15. A pair of fog lamps must emit light that is approximately equal in colour and intensity.
16. The centre of a front fog lamp beam must be parallel to or to the left of the longitudinal centreline of the vehicle.
17. The centre of a front fog lamp beam must be permanently dipped at an angle of at least 3%.
18. A fog lamp must be able to be turned off from the driver's seating position.
19. A front or rear fog lamp warning device must be in good working order.
20. Where a fog lamp comprises an array of light sources (eg LEDs), at least 75% of these must operate.

Modifications

22. A fog lamp that is affected by a modification:
 - a) must meet equipment, condition and performance requirements, and
 - b) does not require LVV specialist certification.

Page amended **1 April 2024** (see [amendment details](#)).

4-3 Cornering lamps

Reasons for rejection

Permitted equipment

1. A vehicle is fitted with:
 - a) only one lamp, or
 - b) more than one pair of lamps, or
 - c) a lamp that either:
 - i. was not originally fitted by the vehicle manufacturer, or
 - ii. is not fitted in the original position.

Condition

2. A lamp is insecure.
3. A lens is missing, or has a hole, crack or other damage that allows moisture or dirt to enter.
4. A lamp's reflector is damaged or has deteriorated so that light output is reduced.

Performance

5. When activated by switching on the direction indicator lamp or by turning the steering wheel, a cornering lamp:
 - a) does not operate, or
 - b) does not project in the direction of the turn.
6. A cornering lamp emits light that is:
 - a) not substantially white or amber, or
 - b) not approximately equal in colour or intensity from the other lamp in the pair, or
 - c) not steady, or
 - d) not bright enough to illuminate the road ahead in the direction of the turn, eg due to modification, deterioration, dirt or or an incorrect light source, or
 - e) too bright causing dazzle to other road users, eg due to an incorrect light source or misalignment, or
 - f) altered, eg due to damage or modification.
7. Where a cornering lamp comprises an array of light sources (eg LEDs), fewer than 75% of these operate.

Note 1

Cornering lamp means a lamp designed to emit light at the front of a vehicle to supplement the vehicle's headlamps by illuminating the road ahead in the direction of the turn.

Note 2

An **original equipment (OE) lamp** is one that is fitted by the vehicle manufacturer in the original position, or is an equivalent replacement or aftermarket lamp suitable for the position provided by the vehicle manufacturer for that lamp. All other lamps are considered retrofitted (ie non-OE).

Note 3

A vehicle originally manufactured with a cornering lamp arrangement that differs from what is required or permitted in this section may retain the original cornering lamps provided they remain fitted in their original position and perform as intended by the vehicle manufacturer.

Note 4

A forward-facing permitted lamp that does not comply with the equipment, condition and performance requirements must **be disabled so that it does not emit a light**.

Summary of legislation

Applicable legislation

- [Land Transport Rule: Vehicle Lighting 2004](#).

Permitted equipment

1. One pair of cornering lamps fitted as OE.

Condition

2. A cornering lamp must be in sound condition.

Performance

3. A cornering lamp must operate in a way that is appropriate for the lamp and the vehicle.
4. A cornering lamp must emit light that is substantially white or amber.
5. A pair of cornering lamps must emit light that is approximately equal in colour and intensity.
6. A cornering lamp must emit a steady light.
7. A cornering lamp must provide sufficient light output to illuminate the road ahead in the direction of the turn.
8. A cornering lamp must be correctly aligned.
9. Where a cornering lamp comprises an array of light sources (eg LEDs), at least 75% of these must operate.

Modifications

10. A cornering lamp that is affected by a modification:
 - a) must meet equipment, condition and performance requirements, and
 - b) does not require LVV specialist certification.

Page amended 1 December 2016 (see [amendment details](#)).

4-4 Daytime running lamps

Reasons for rejection

Permitted equipment

1. A vehicle other than class LE is fitted with:
 - a) only one lamp, or
 - b) more than one pair of lamps.
2. A vehicle of class LE is fitted with more than two lamps.
3. A lamp is fitted in a position other than at the front of the vehicle.
4. A retrofitted lamp is not:
 - a) symmetrically mounted, or
 - b) mounted as far towards each side of the vehicle as is practicable.

Condition

5. A lamp is insecure.
6. A lens is missing, or has a hole, crack or other damage that allows moisture or dirt to enter.

7. A lamp's reflector is damaged or has deteriorated so that light output is reduced.

Performance

8. When switched on, a daytime running lamp does not operate (Note 4).

9. When switched on, a daytime running lamp emits light that is:

- a) projected in a direction other than to the front, or
- b) not substantially white or amber, or
- c) not approximately equal in colour or intensity from the other lamp in the pair, or
- d) not steady, or
- e) not bright enough to make the vehicle more easily seen during the daytime, eg due to modification, deterioration, dirt or or an incorrect light source, or
- f) too bright, causing significant dazzle to other road users, eg due to an incorrect light source, or
- g) altered, eg due to damage or modification.

10. Where a daytime running lamp comprises an array of light sources, fewer than 75% of these operate.

11. A daytime running lamp continues to operate when the headlamps or fog lamps are switched on.

Note 1

Daytime running lamp means a lamp designed to emit a low-intensity light forward of a vehicle to make it more easily seen in the daytime.

Note 2

A vehicle originally manufactured with a daytime running lamp arrangement that differs from what is required or permitted in this section may retain the original daytime running lamps provided they remain fitted in their original position and perform as intended by the vehicle manufacturer.

Note 3

A forward-facing permitted lamp that does not comply with the equipment, condition and performance requirements must be made to comply or **be disabled so that it does not emit a light**.

Note 4

Some vehicles are equipped with OE or after-market daytime running lamps (DRLs) that also incorporate position lamp and direction indicator lamp functions. When the DRLs are on (when headlamps are off), and an indicator lamp is activated, the corresponding DRL is temporarily extinguished or dimmed. When the position lamps are on and an indicator lamp is activated, the corresponding position lamp may remain lit.

Summary of legislation

Applicable legislation

- [Land Transport Rule: Vehicle Lighting 2004](#).

Permitted equipment

1. A vehicle other than class LE may have: one pair of daytime running lamps fitted to the front of the vehicle.
2. A vehicle of class LE may have one or two daytime running lamps fitted to the front of the vehicle.
3. A retrofitted lamp must be symmetrically mounted as far towards each side of the vehicle as is practicable.

Condition

4. A daytime running lamp must be in sound condition.

Performance

5. A daytime running lamp must operate in a way that is appropriate for the lamp and the vehicle.
6. A daytime running lamp must emit light that is substantially white or amber.
7. A pair of daytime running lamps must emit light that is of approximately equal colour and intensity.
8. A daytime running lamp must emit a steady light.
9. A daytime running lamp must provide sufficient light output to make the vehicle more easily seen during the daytime.
10. A daytime running lamp must be correctly aligned.
11. A daytime running lamp must not operate when a front fog lamp or a headlamp is in use.
12. Where a daytime running lamp comprises an array of light sources (eg LEDs), at least 75% of these must operate.

Modifications

13. A daytime running lamp that is affected by a modification:
 - a) must meet equipment, condition and performance requirements, and
 - b) does not require LVV specialist certification.

Page amended **1 December 2016** (see [amendment details](#)).

4-5 Direction indicator lamps

Reasons for rejection

Mandatory and permitted equipment

1. A vehicle of class LE first registered in New Zealand on or after 1 January 1978 is not fitted with one pair of lamps to the front and one pair of lamps to the rear.
2. A vehicle of class LE first registered in New Zealand before 1 January 1978 is fitted with more than one pair of lamps to the front or more than one pair of lamps to the rear.

3. A vehicle other than class LE first registered anywhere on or after 1 July 1967 is not fitted with one pair of lamps to the front and one pair of lamps to the rear.
4. A vehicle is fitted with more than:
 - a) two pairs of lamps to the front, or
 - b) two pairs of lamps to the rear, or
 - c) three pairs of lamps (including top-mounted lamps) to the rear if the vehicle is an emergency vehicle.
5. An emergency vehicle is fitted at the rear with:
 - a) more than one pair of top-mounted lamps, or
 - b) top-mounted lamps that are not mounted as close as is practicable to the top corners of the bodywork.
6. A vehicle is fitted with more than two side-facing lamps on each side of the vehicle.
7. A vehicle is fitted with a lamp that is not in a pair.
8. A vehicle is not fitted with a visual lamp indicator device that indicates to the driver that a lamp has failed (only where one was fitted as original equipment).
9. A retrofitted lamp is not:
 - a) symmetrically mounted, or
 - b) mounted as far towards each side of the vehicle as is practicable.
10. A retrofitted lamp, other than a top-mounted lamp on an emergency vehicle, is fitted at a height from the ground exceeding 1.5m (or 2.1m where fitting below 1.5m is not practicable due to the shape of the bodywork of the vehicle).
11. A vehicle (eg avintage or veteran vehicle) does not meet standard direction indicator lamp requirements, and:
 - a) does not have a valid vehicle identity card with a lighting equipment endorsement, or
 - b) does not meet the conditions of the lighting equipment endorsement in its vehicle identity card.

Condition

12. A lamp is insecure or, if a mandatory lamp, contains moisture in the form of large droplets, runs or puddles.
13. A lens is missing, or has a hole, crack or other damage that allows moisture or dirt to enter.
14. A lamp's reflector is damaged or has deteriorated so that light output is reduced.
15. A visual lamp-failure warning device is obscured from the driver in the driver's seating position.

Performance

16. When switched on, a direction indicator lamp:
 - a) does not operate, or
 - b) does not begin flashing within one second of switching on, or
 - c) flashes:
 - i. faster than two flashes per second, or
 - ii. slower than one flash per second, or
 - iii. at a different rate from other lamps on the same side.

17. When switched on, a direction indicator lamp emits a light that is:

- a) not substantially white or amber to the front, or
- b) not substantially amber or red to the rear, or
- c) not substantially amber to the side, or
- d) not approximately equal in colour or intensity from the other lamp in a pair, or
- e) not bright enough to be visible from 100m in normal daylight and from 200m in normal darkness, eg due to modification, deterioration, dirt or an incorrect light source, or
- f) too bright causing significant dazzle to other road users, eg due to an incorrect light source , or
- g) altered, eg due to damage or modification.

18. A non-OE mandatory lamp mounted outside the original position emits a light that is not visible within (Figure 4-5-1):

- a) 15° above and below the horizontal, or
- b) 45° inboard or 80° outboard.

19. An overlay has been applied that reduces or distorts the light emitted from the lamp (eg a tinted cover).

20. A modification to the vehicle has reduced the visibility angles of a mandatory lamp to less than (Figure 4-5-1):

- a) 15° above and below the horizontal, or
- b) 45° inboard or 80° outboard.

21. On a vehicle of American origin fitted with combined stop and indicator lamps, the stop lamp function is not overridden by the indicator function.

22. Where a lamp comprises an array of light sources (eg LEDs), fewer than 75% of these operate.

23. A visual lamp indicator device does not operate.

Note 1 Definitions

Modify means to change a vehicle from its original state by altering, substituting, adding or removing a structure, system, component or equipment, but does not include repair.

Repair means to restore a damaged or worn vehicle, its structure, systems, components or equipment to within safe tolerance of its condition when manufactured, including replacement with undamaged or new structures, systems, components or equipment.

Direction indicator lamp means a lamp designed to emit a flashing light to signal the intention of the driver to change the direction of the vehicle to the right or to the left.

Note 2

A permitted (ie non-mandatory) rear or a non-OE side-facing direction indicator lamp that does not comply with equipment, condition and performance requirements must be made to comply or disabled so that it does not emit a light.

Note 3

An **original equipment (OE) lamp** is one that is fitted by the vehicle manufacturer in the original position, or is an equivalent replacement or aftermarket lamp suitable for the position provided by the vehicle manufacturer for that lamp. All other lamps are considered retrofitted (ie non-OE).

Note 4

Vehicles first registered in New Zealand before 27 February 2005 may have rear direction indicator lamps that also function as reversing lamps.

Note 5

A vehicle originally manufactured with a direction indicator lamp arrangement that differs from what is required or permitted in this section may retain the original direction indicator lamps provided they remain fitted in their original position and perform as intended by the vehicle manufacturer.

Note 6

A forward-facing permitted lamp that does not comply with the equipment, condition and performance requirements must be made to comply or be removed from the vehicle.

Note 7

Some vehicles are equipped with OE or after-market daytime running lamps (DRLs) that also incorporate position lamp and direction indicator lamp functions. When the DRLs are on (when headlamps are off), and an indicator lamp is activated, the corresponding DRL is temporarily extinguished or dimmed. When the position lamps are on and an indicator lamp is activated, the corresponding position lamp may remain lit.

Figure 4-5-1. Direction indicator beam angles

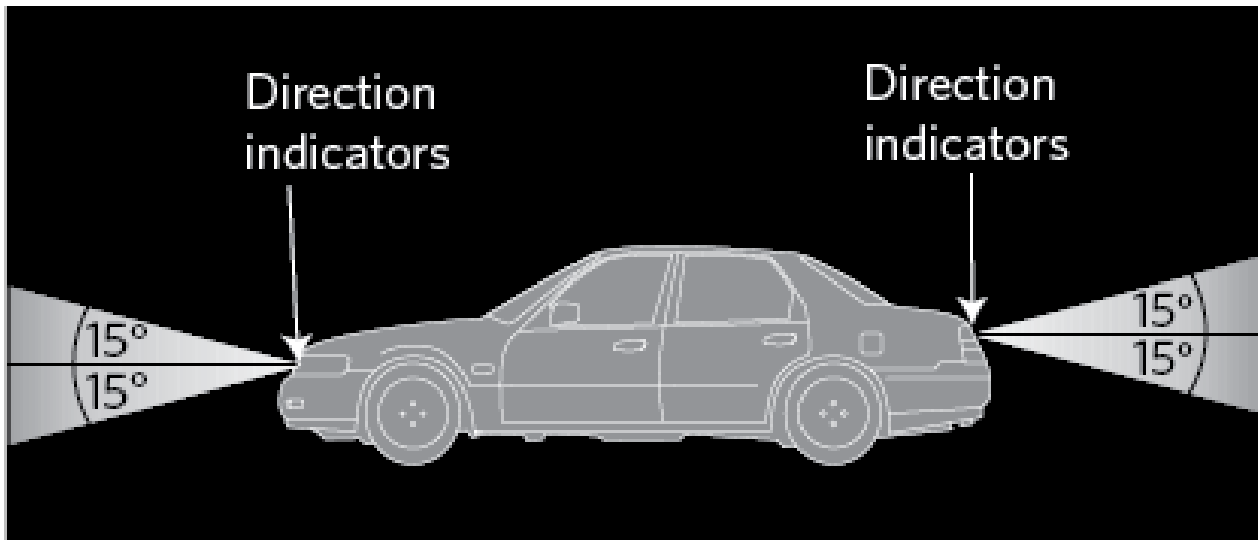

(a) Vertical beam angles

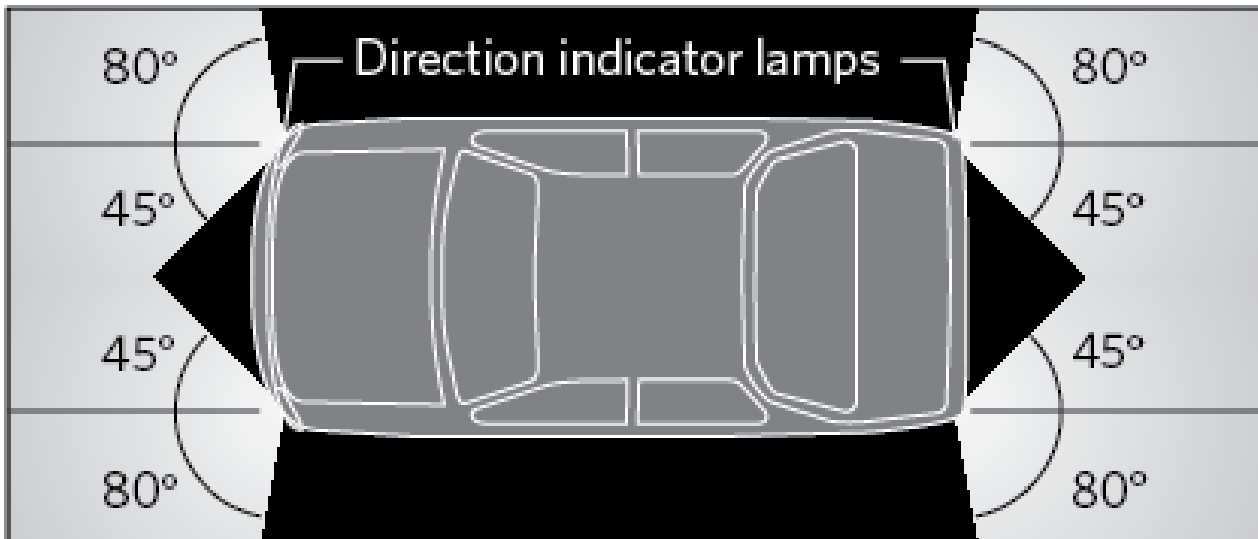

(b) Horizontal beam angles

Summary of legislation

Applicable legislation

- [Land Transport Rule: Vehicle Lighting 2004.](#)

Mandatory and permitted equipment

1. A vehicle other than class LE first registered anywhere before 1 July 1967 may be fitted with one or two pairs of lamps to the front and one or two pairs of lamps to the rear of the vehicle.

2. A vehicle other than class LE first registered anywhere on or after 1 July 1967 must be fitted with one or two pairs of lamps to the front and one or two pairs of lamps to the rear of the vehicle.
3. A vehicle of class LE first registered in New Zealand before 1 January 1978 may be fitted with one pair of lamps to the front and one pair of lamps to the rear of the vehicle.
4. A vehicle of class LE first registered in New Zealand on or after 1 January 1978 must be fitted with one or two pairs of lamps to the front and one or two pairs of lamps to the rear of the vehicle.
5. An emergency vehicle may be fitted with an additional pair of indicator lamps at the rear of the vehicle that must be symmetrically mounted as near to the top corners of the bodywork of the vehicle as is practicable (top-mounted lamps).
6. A vehicle may be fitted with one or two side-facing lamps on each side.
7. A suitable device must be fitted that indicates to the driver the failure of a mandatory lamp.
8. A vehicle (eg a vintage or veteran vehicle) manufactured without lamps, or with lamps that cannot meet specified requirements, may obtain a WoF if:
 - a) the vehicle has a valid vehicle identity card with a lighting equipment endorsement, and
 - b) the vehicle meets the conditions of that endorsement.
9. A retrofitted pair of lamps, other than top-mounted lamps, must be mounted:
 - a) symmetrically as far towards each side of the vehicle as is practicable, and
 - b) at a height from the ground not exceeding 1.5 m, or if this is not practicable due to the shape of the bodywork of the vehicle, not exceeding 2.1 m.
10. On vehicles of American origin, the stop lamp and direction indicator lamp function may be combined in one lamp.

Condition

11. A direction indicator lamp must:
 - a) be in sound condition, and
 - b) not be obscured (if a mandatory lamp).

Performance

12. A direction indicator lamp must operate in a way that is appropriate for the lamp and the vehicle.
13. A direction indicator lamp must emit a light that is substantially:
 - a) white or amber to the front, and
 - b) red or amber to the rear, and
 - c) amber to the side.
14. A lamp must flash at a fixed frequency in the range of 1–2 Hertz.
15. Each lamp in a pair must, when operated, emit a light of approximately equal intensity, colour and frequency.
16. The lamp-failure indicating device must function.
17. A lamp must emit a light that is visible from 100m during normal daylight and 200m in normal darkness.
18. A retrofitted mandatory lamp must emit a light that is visible within angles of
 - a) 15° above and below the horizontal, and

b) 45? inboard, and

c) 80? outboard.

19. If a vehicle of American origin is fitted with combined stop and indicator lamps, the indicator lamps must override the stop lamps so that the stop lamps operate as direction indicators.

20. Where a lamp comprises an array of light sources (eg LEDs), at least 75% of these must operate.

Modifications (Note 1)

21. A direction indicator lamp that is affected by a modification must meet equipment, condition and performance requirements.

Page amended **2 December 2019** (see [amendment details](#)).

4-6 Forward-facing position lamps

Reasons for rejection

Mandatory and permitted equipment

1. One pair of lamps is not fitted to:

a) a vehicle first registered in New Zealand on or after 1 January 1978 that exceeds 1.5m in width, or

b) a vehicle that exceeds 2m in width.

2. A vehicle is fitted with more than:

a) one pair of lamps, or

b) two single lamps.

3. A vehicle (eg a vintage or veteran vehicle) does not meet standard forward-facing position lamp requirements, and:

a) does not have a valid vehicle identity card with a lighting equipment endorsement, or

b) does not meet the conditions of the lighting equipment endorsement in its vehicle identity card.

4. A retrofitted lamp is mounted at a height from the ground exceeding 1.5m (or 2.1m where fitting below 1.5m is not practicable due to the shape of the bodywork of the vehicle).

5. A retrofitted pair of lamps is:

a) not symmetrically mounted, or

b) not mounted as far towards each side of the vehicle as is practicable.

Condition

6. A lamp is insecure or, if a mandatory lamp, contains moisture in the form of large droplets, runs or puddles.

7. A lens is missing, or has a hole, crack or other damage that allows moisture or dirt to enter.

8. A lamp's reflector is damaged or has deteriorated so that light output is reduced.

Performance

9. When switched on, a forward-facing position lamp does not operate (Note 5).

10. When switched on, a forward-facing position lamp emits a light that is:
- a) not substantially white or amber, or
 - b) not diffuse, or
 - c) not projected to the front, or
 - d) not approximately equal in colour or intensity from the other lamp in a pair, or
 - e) not steady, or
 - f) not bright enough to be visible from 200m in normal darkness, eg due to modification, deterioration, dirt or an incorrect light source, or
 - g) is altered, eg due to damage or modification.
11. A non-OE mandatory lamp mounted outside the original position emits a light that is not visible within (Figure 4-6-1):
- a) 15° above and below the horizontal, or
 - b) 45° inboard or 80° outboard.
12. A modification to the vehicle has reduced the visibility angles of a mandatory lamp to less than (Figure 4-6-1):
- a) 15° above and below the horizontal, or
 - b) 45° inboard or 80° outboard.
13. An overlay has been applied that reduces or distorts the light emitted from the lamp (eg a tinted cover).
14. Where a lamp comprises an array of light sources (eg LEDs), fewer than 75% of these operate.

Note 1 Definitions

Modify means to change a vehicle from its original state by altering, substituting, adding or removing a structure, system, component or equipment, but does not include repair.

Repair means to restore a damaged or worn vehicle, its structure, systems, components or equipment to within safe tolerance of its condition when manufactured, including replacement with undamaged or new structures, systems, components or equipment.

Position lamp means a low-intensity lamp that is designed to indicate to road users the presence and dimensions of a vehicle, being:

- a) a forward-facing position lamp (front side lamp), or
- b) a rearward-facing position lamp (rear side lamp or tail lamp), or
- c) a side-marker lamp, or
- d) an end-outline marker lamp (including cab roof lamp).

Note 2

An **original equipment (OE) lamp** is one that is fitted by the vehicle manufacturer in the original position, or is an equivalent replacement or aftermarket lamp suitable for the position provided by the vehicle manufacturer for that lamp. All other lamps are considered retrofitted (ie non-OE).

Note 3

A vehicle originally manufactured with a forward-facing position lamp arrangement that differs from what is required or permitted in this section may retain the original forward-facing position lamps provided they remain fitted in their original position and perform as intended by the vehicle manufacturer.

Note 4

A forward-facing permitted lamp that does not comply with the equipment, condition and performance requirements must be made to comply or be removed from the vehicle.

Note 5

Some vehicles are equipped with OE or after-market daytime running lamps (DRLs) that also incorporate position lamp and direction indicator lamp functions. When the DRLs are on (when headlamps are off), and an indicator lamp is activated, the corresponding DRL is temporarily extinguished or dimmed. When the position lamps are on and an indicator lamp is activated, the corresponding position lamp may remain lit.

Figure 4-6-1. Forward-facing position lamp beam angles

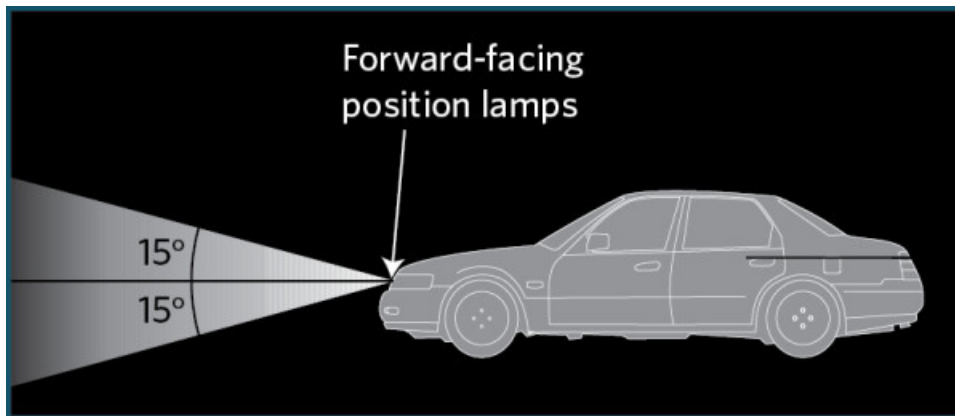

(a) Vertical beam angles

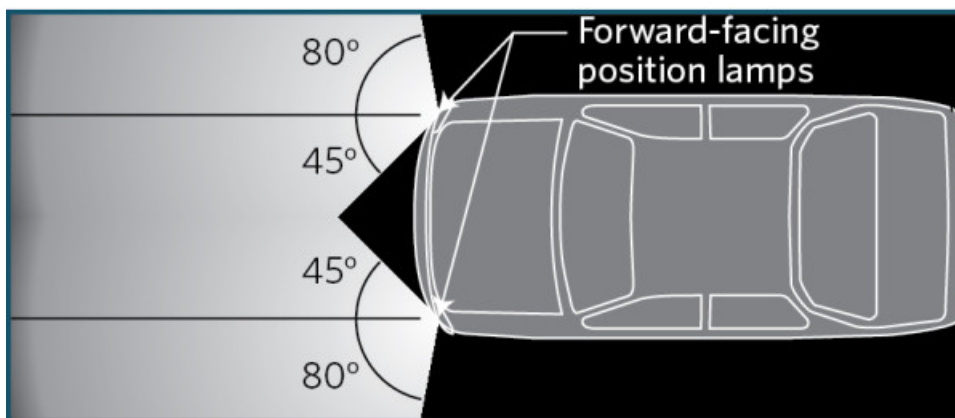

(b) Horizontal beam angles

Summary of legislation

Applicable legislation

- [Land Transport Rule: Vehicle Lighting 2004](#).

Mandatory and permitted equipment

1. One pair of lamps must be fitted to:

- a) a vehicle first registered in New Zealand on or after 1 January 1978 that exceeds 1.5m in width
- b) a vehicle that exceeds 2m in width.

2. One or two lamps may be fitted to:

- a) a vehicle that does not exceed 1.5m in width
- b) a vehicle first registered in New Zealand before 1 January 1978 that does not exceed 2m in width.

3. A vehicle (eg a vintage or veteran vehicle) manufactured without lamps, or with lamps that cannot meet specified requirements, may obtain a WoF if:

- a) the vehicle has a valid vehicle identity card with a lighting equipment endorsement, and
- b) the vehicle meets the conditions of that endorsement.

4. A retrofitted pair of lamps must be symmetrically mounted as far towards each side of the vehicle as is practicable.

5. A retrofitted lamp must be mounted at a height from the ground not exceeding 1.5m, or if this is not practicable due to the shape of the bodywork of the vehicle, not exceeding 2.1m.

Condition

6. A forward-facing position lamp must:

- a) be in sound condition
- b) not be obscured (if a mandatory lamp).

Performance

7. A forward-facing position lamp must operate in a way that is appropriate for the lamp and the vehicle.

8. A lamp must emit a light that is:

- a) diffuse, and
- b) substantially white or amber, and
- c) steady, and
- d) sufficient to indicate to other road users the presence and dimensions of the vehicle, and
- e) visible from 200m in normal darkness, and
- f) of approximately equal intensity and colour to the other lamp of a pair.

9. A retrofitted mandatory lamp must be visible within angles of:

- a) 15° above and below the horizontal, and

b) 45° inboard, and

c) 80° outboard.

10. Where a lamp comprises an array of light sources (eg LEDs), at least 75% of these must operate.

Modifications (Note 1)

11. A forward-facing position lamp that is affected by a modification must meet the equipment, condition and performance requirements.

Page amended **2 December 2019** (see [amendment details](#)).

4-7 Rearward-facing position lamps

Reasons for rejection

Mandatory and permitted equipment

1. A vehicle first registered in New Zealand on or after 1 January 1978 that is more than 1.5m wide:
 - a) is not fitted with one pair of lamps, or
 - b) is fitted with more than two pairs of lamps, or
 - c) is fitted with a lamp that is not in a pair, or
 - d) is an emergency vehicle and is fitted with more than three pairs of lamps, including top-mounted lamps.
2. A group M or N vehicle first registered in New Zealand before 1 January 1978 or is less than 1.5m wide is:
 - a) not fitted with one single lamp or one pair of lamps, or
 - b) fitted with more than one single lamp, or
 - c) fitted with more than two pairs of lamps.
3. An emergency vehicle is fitted with:
 - a) more than one pair of top-mounted lamps, or
 - b) top-mounted lamps that are not mounted as close as is practicable to the top corners of the bodywork.
4. A class LE vehicle that was first registered in New Zealand before 1 January 1978 or that is less than 1.5m wide is not fitted with at least one lamp.
5. A vehicle (eg a vintage or veteran vehicle) does not meet standard rearward-facing position lamp requirements, and:
 - a) does not have a valid vehicle identity card with a lighting equipment endorsement, or
 - b) does not meet the conditions of the lighting equipment endorsement in its vehicle identity card.
6. A retrofitted lamp, other than a top-mounted lamp on an emergency vehicle, is mounted at a height from the ground exceeding 1.5m (or 2.1m where fitting below 1.5m is not practicable due to the shape of the bodywork of the vehicle).
7. A retrofitted pair of lamps:
 - a) is not symmetrically mounted, or
 - b) is not mounted as far towards each side of the vehicle as is practicable.

Condition

8. A lamp is insecure or, if a mandatory lamp, contains moisture in the form of large droplets, runs or puddles.
9. A lens is missing, or has a hole, crack or other damage that allows moisture or dirt to enter.
10. A lamp's reflector is damaged or has deteriorated so that light output is reduced.

Performance

11. When switched on, a mandatory lamp does not operate.
12. When switched on, a lamp emits a light that is:
 - a) not substantially red, or
 - b) not diffuse, or
 - c) not projected to the rear, or
 - d) not approximately equal in colour or intensity from that of the other lamp in a pair, or
 - e) not steady, or
 - f) not bright enough to be visible from 200m in normal darkness, eg due to modification, deterioration, dirt or an incorrect light source, or
 - g) is altered, eg due to damage or modification.
13. A non-OE mandatory lamp mounted outside the original position emits a light that is not visible within (Figure 4-7-1):
 - a) 15° above and below the horizontal, or
 - b) 45° inboard or 80° outboard.
14. A modification to the vehicle has reduced the visibility angles of a mandatory lamp to less than (Figure 4-7-1):
 - a) 15° above and below the horizontal, or
 - b) 45° inboard or 80° outboard.
15. An overlay has been applied that reduces or distorts the light emitted from the lamp (eg a tinted cover).
16. Where a lamp comprises an array of light sources (eg LEDs), fewer than 75% of these operate.

Note 1 Definitions

Modify means to change a vehicle from its original state by altering, substituting, adding or removing a structure, system, component or equipment, but does not include repair.

Repair means to restore a damaged or worn vehicle, its structure, systems, components or equipment to within safe tolerance of its condition when manufactured, including replacement with undamaged or new structures, systems, components or equipment.

Position lamp means a low-intensity lamp that is designed to indicate to road users the presence and dimensions of a vehicle, being:

- a) a forward-facing position lamp (front side lamp), or
- b) a rearward-facing position lamp (rear side lamp or tail lamp), or
- c) a side-marker lamp, or

d) an end-outline marker lamp (including cab roof lamp).

Note 2

A permitted rearward-facing position lamp that does not comply with equipment, condition and performance requirements must be made to comply or be disabled so that it does not emit a light.

Note 3

An original equipment (OE) lamp is one that is fitted by the vehicle manufacturer in the original position, or is an equivalent replacement or aftermarket lamp suitable for the position provided by the vehicle manufacturer for that lamp. All other lamps are considered retrofitted (ie non-OE).

Note 4

A vehicle originally manufactured with a rearward-facing position lamp arrangement that differs from what is required or permitted in this section may retain the original rearward-facing position lamps provided they remain fitted in their original position and perform as intended by the vehicle manufacturer.

Figure 4-7-1. Rearward-facing position lamp beam angles

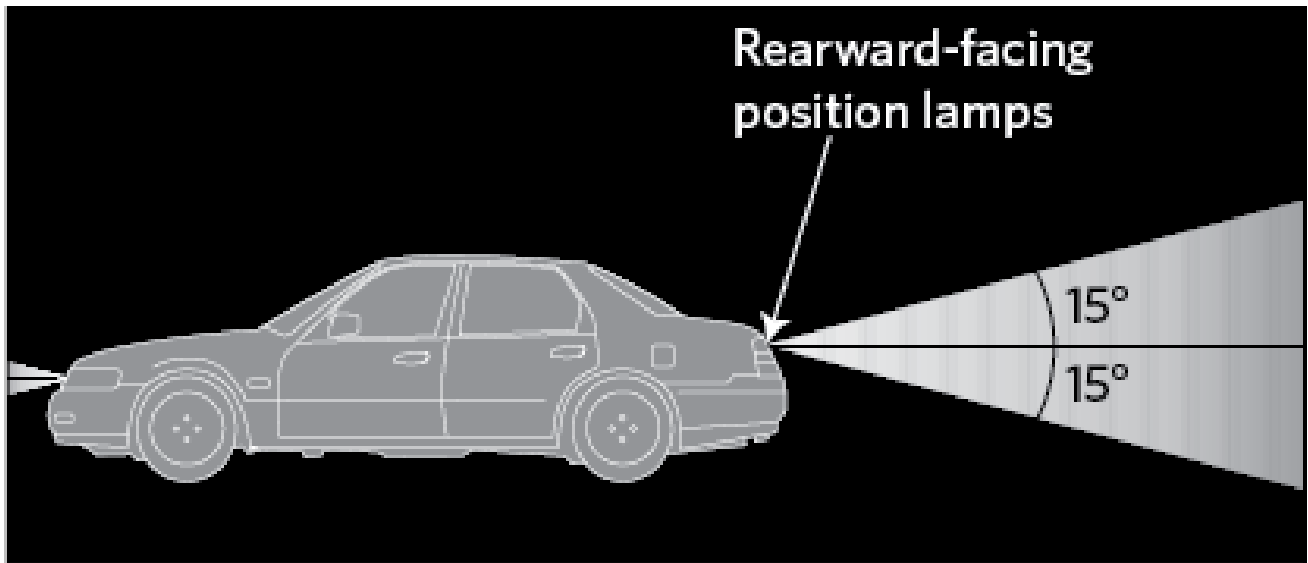

(a) Vertical beam angles

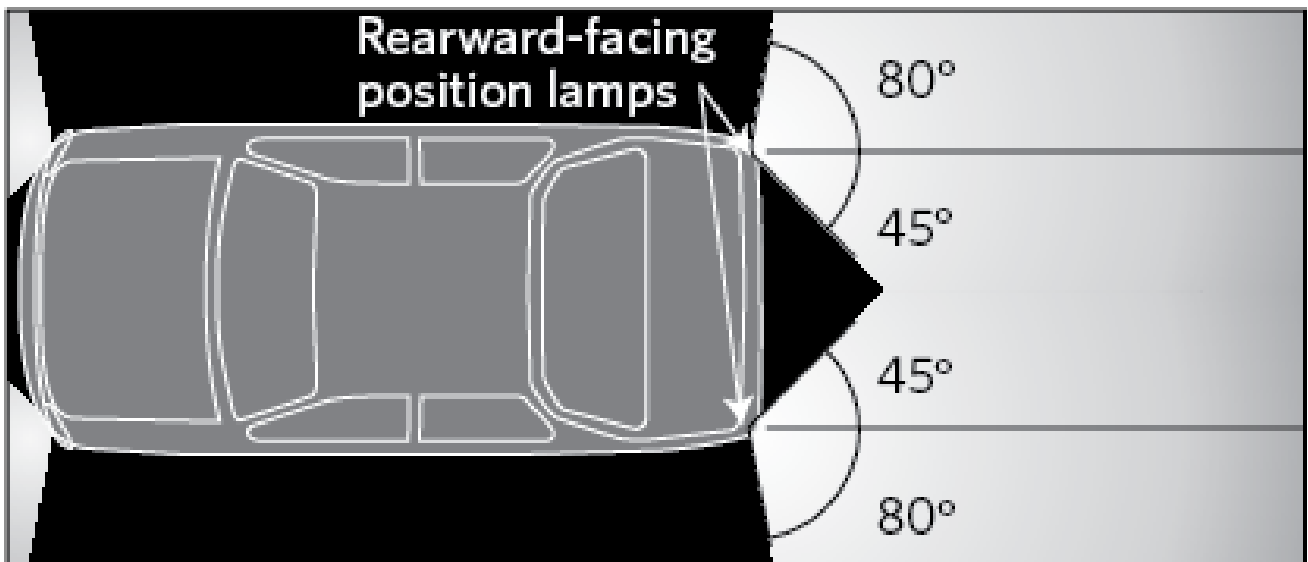

(b) Horizontal beam angles

Summary of legislation

Applicable legislation

- [Land Transport Rule: Vehicle Lighting 2004](#)

Mandatory and permitted equipment

1. A vehicle first registered in New Zealand on or after 1 January 1978 and that is more than 1.5m wide must be fitted with one or two pairs of rearward-facing position lamps.
2. A vehicle of group M or N that was first registered in New Zealand before 1 January 1978 or that does not exceed 1.5m in width must be fitted with:

- a) one single rearward-facing position lamp in the centre or to the right of the centre of the vehicle, or
 - b) one or two pairs of rearward-facing position lamps.
3. A vehicle of class LE that was first registered in New Zealand before 1 January 1978 or that does not exceed 1.5m in width must be fitted with at least one rearward-facing position lamp.
4. An emergency vehicle may be fitted with an additional pair of lamps that must be symmetrically mounted as near the top corners of the bodywork of the vehicle as is practicable (top-mounted lamps).
5. A vehicle (eg a vintage or veteran vehicle) manufactured without lamps, or with lamps that cannot meet specified requirements, may obtain a WoF if:
- a) the vehicle has a valid vehicle identity card with a lighting equipment endorsement, and
 - b) the vehicle meets the conditions of that endorsement.
6. A retrofitted pair of lamps, other than top-mounted lamps, must be mounted:
- a) symmetrically as far towards each side of the vehicle as is practicable, and
 - b) at a height from the ground not exceeding 1.5m, or if this is not practicable due to the shape of the bodywork of the vehicle, not exceeding 2.1m.

Condition

7. A rearward-facing position lamp must:
- a) be in sound condition, and
 - b) not be obscured (if a mandatory lamp).

Performance

8. A rearward-facing position lamp must operate in a way that is appropriate for the lamp and the vehicle.
9. A lamp must emit a light that is:
- a) diffuse, and
 - b) substantially red.
10. A lamp must emit a steady light.
11. A lamp must provide sufficient light output to indicate to other road users the presence and dimensions of the vehicle.
12. A lamp must emit light that is visible from a distance of 200m in normal darkness.
13. A retrofitted mandatory lamp must be visible within angles of 15° above and below the horizontal, and within 45° inboard and 80° outboard.
14. Each lamp in a pair must, when operated, emit a light of approximately equal intensity and colour.
15. Where a lamp comprises an array of light sources (eg LEDs), at least 75% of these must operate.

Modifications (Note 4)

16. A rearward-facing position lamp that is affected by a modification must meet equipment, condition and performance requirements.

4-8 Side-marker lamps

Reasons for rejection

Permitted and prohibited equipment

1. A side-marker lamp is not positioned so that it gives an indication of the vehicle's dimensions.
2. A vehicle less than 6m in length is fitted with a side-marker lamp, unless the vehicle is a production vehicle and the lamp is fitted as original equipment by the vehicle manufacturer.
3. A vehicle manufactured **before 1 January 2006** has a forward-facing side-marker lamp that emits light that is not substantially white or amber.
4. A vehicle manufactured **on or after 1 January 2006** has a forward-facing side-marker lamp that emits light that is not substantially amber.

Condition

5. A lamp is insecure.
6. A lens is missing, or has a hole, crack or other damage that allows moisture or dirt to enter.
7. A reflector is damaged or has deteriorated so that light output is reduced.

Performance

8. When switched on, a side-marker lamp emits a light that:
 - a) is not substantially white or amber to the front, or
 - b) is not substantially red or amber to the rear, or
 - c) is not diffuse, or
 - d) is not approximately of the same colour and intensity on each side of the vehicle, or
 - e) does not remain steadily illuminated, or
 - f) is not bright enough to produce light that is visible from 100m in normal daylight and from 200m in normal darkness, eg due to modification, deterioration, dirt or an incorrect light source.
9. Where a lamp comprises an array of light sources (eg LEDs), fewer than 75% of these operate.

Modifications

9. A side-marker lamp that is affected by a modification must meet equipment, condition and performance requirements.

Note 1 Definitions

Side-marker lamp means a position lamp designed to be fitted to the side of a vehicle or its load.

Position lamp means a low-intensity lamp that is designed to indicate to road users the presence and dimensions of a vehicle, being:

- a) a forward-facing position lamp (front side lamp), or

- b) a rearward-facing position lamp (rear side lamp or tail lamp), or
- c) a side-marker lamp, or
- d) an end-outline marker lamp (including cab roof lamp).

Note 2

A permitted side-marker lamp that does not comply with equipment, condition and performance requirements must be made to comply or be disabled so that it does not emit a light.

Figure 4-8-1. Visibility angles for side marker lamps

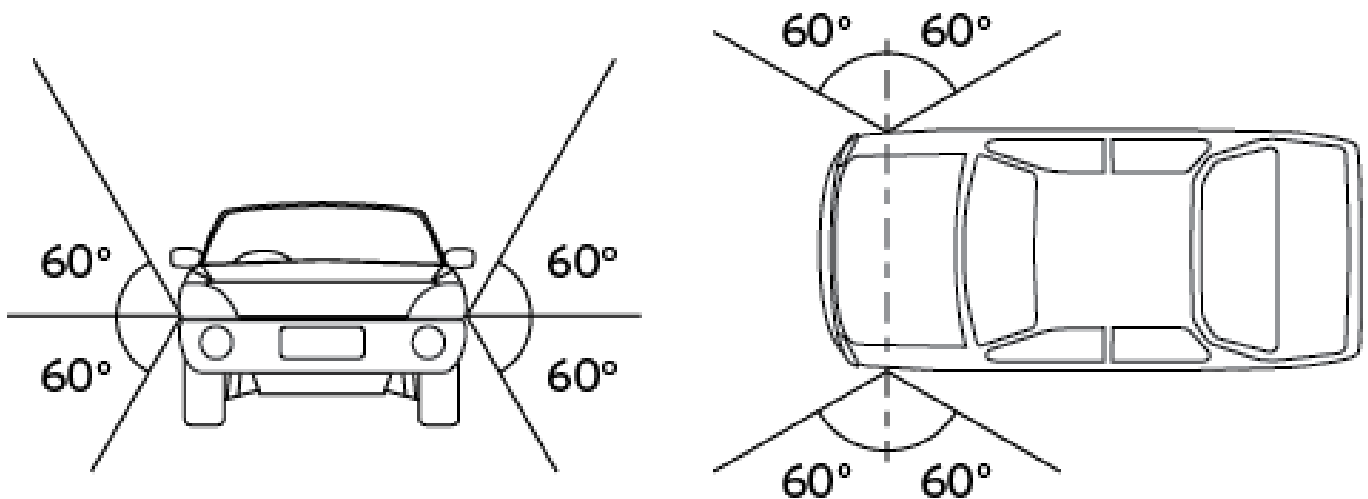

Summary of legislation

Applicable legislation

- [Land Transport Rule: Vehicle Lighting 2004](#).

Permitted and prohibited equipment

1. A light vehicle 6m or more in length may be fitted with one or more side-marker lamps.
2. A side-marker lamp must be positioned so that it gives an indication of the vehicle's dimensions.
3. A light vehicle less than 6m in length must not be fitted with a side-marker lamp, unless the vehicle is a production vehicle and the lamp is fitted as original equipment by the vehicle manufacturer.
4. The light emitted from a forward-facing side-marker lamp on a vehicle manufactured before 1 January 2006 is not substantially white or amber.
5. The light emitted from a forward-facing side-marker lamp on a vehicle manufactured on or after 1 January 2006 is not substantially amber.

Condition

6. A side-marker lamp must be in sound condition.

Performance

7. A side-marker lamp must operate in a way that is appropriate for the lamp and the vehicle.
8. A lamp must emit a light that is:
 - a) diffuse, and
 - b) substantially white or amber to the front, and
 - c) substantially red or amber to the rear.
7. A lamp must emit a steady light.
9. A side-marker lamp must provide sufficient light output to indicate to other road users the presence and dimensions of the vehicle.
10. A side-marker lamp must emit a light that is visible from a distance of 100m in daylight and 200m during the hours of darkness.
11. Where a lamp comprises an array of light sources (eg LEDs), at least 75% of these must operate.

Modifications

12. A side-marker lamp that is affected by a modification must meet equipment, condition and performance requirements.

Page amended **1 December 2016** (see [amendment details](#)).

4-9 End-outline marker lamps

Reasons for rejection

Permitted and prohibited equipment

1. A light vehicle with an overall width of 1.8m or more is fitted with:
 - a) more than four forward-facing lamps, or
 - b) more than two rearward-facing lamps.
2. A light vehicle with an overall width of less than 1.8m is fitted with end-outline marker lamps.
3. The lamps are not positioned in such a way that they give an indication of the vehicles dimensions.

Condition

4. A lamp is insecure.
5. A lens is missing, or has a hole, crack or other damage that allows moisture or dirt to enter.
6. A reflector is damaged or has deteriorated so that light output is reduced.

Performance

7. When switched on, a forward-facing end-outline marker lamp does not operate (Note 2).
8. When switched on, an end-outline marker lamp emits a light that is:
 - a) not substantially white or amber to the front, or

- b) not substantially red to the rear, or
- c) not diffuse, or
- d) not projected to the front or rear, or
- e) not approximately of the same colour or intensity as the other lamp if fitted in a pair, or
- f) not steady, or
- g) not bright enough to indicate the presence and dimensions of the vehicle to other road users.

9. Where a lamp comprises an array of light sources (eg LEDs), fewer than 75% of these operate.

Note 1 Definitions

End-outline marker lamp means a position lamp designed to be fitted near the outer extremity of the vehicle in addition to forward-facing and rearward-facing position lamps, and includes a cab roof lamp.

Position lamp means a low-intensity lamp that is designed to indicate the presence and dimensions of a vehicle to other road users, being:

- a) a forward-facing position lamp (front side or park lamp), or
- b) a rearward-facing position lamp (rear side lamp or tail lamp), or
- c) a side-marker lamp, or
- d) an end-outline marker lamp (including cab roof lamp).

Note 2

A rearward-facing end-outline marker lamp that does not comply with the equipment, condition and performance requirements, must be made to comply or be disabled so that it does not emit a light. A non-complying forward-facing end-outline marker lamp must be made to comply or be fully removed from the vehicle.

Note 3

A vehicle originally manufactured with an end-outline marker lamp arrangement that differs from what is required or permitted in this section may retain the original end-outline marker lamps provided they remain fitted in their original position and perform as intended by the vehicle manufacturer. Lamps visible from the front and from the rear on the same side of the vehicle may be combined into one device.

Note 4

Vehicle manufacturer means the original vehicle manufacturer and the final stage manufacturer in the case of certain modified vehicles (see [Technical bulletin 13: Acceptable overseas proof of modification](#)).

Summary of legislation

Applicable legislation

- [Land Transport Rule: Vehicle Lighting 2004](#).

Permitted and prohibited equipment

1. A light vehicle that has an overall width of 1.8m or more may be fitted with a maximum of:
 - a) four forward-facing lamps, and
 - b) two rearward-facing lamps.
2. The position of the lamps must be such that it gives an indication of the vehicle's dimensions.
3. A light vehicle with an overall width of less than 1.8m must not be fitted with end-outline marker lamps.

Condition

4. An end-outline marker lamp must be in sound condition.

Performance

5. An end-outline marker lamp must operate in a way that is appropriate for the lamp and the vehicle.
6. A lamp must emit a light that is:
 - a) diffuse, and
 - b) substantially white or amber to the front, and
 - c) substantially red to the rear.
7. A lamp must emit a steady light.
8. An end-outline marker lamp must provide sufficient light output to indicate to other road users the presence and dimensions of the vehicle.
9. Where a lamp comprises an array of light sources (eg LEDs), at least 75% of these must operate.

Modifications

10. An end-outline marker lamp that is affected by a modification must meet equipment, condition and performance requirements.

Page amended **1 November 2018** (see [amendment details](#)).

4-10 Stop lamps

Reasons for rejection

Mandatory and permitted equipment

1. A class LE vehicle first registered in New Zealand on or after 1 January 1978 is not fitted with one stop lamp.
2. A class LE vehicle is fitted with more than two stop lamps.
3. A group M or N vehicle first registered in New Zealand before 1 January 1978:
 - a) is not fitted with one stop lamp if the vehicle is so constructed that the driver's arm signals cannot be seen from behind the vehicle, or
 - b) is fitted with more than four stop lamps.
4. A group M or N vehicle first registered in New Zealand on or after 1 January 1978 is:

- a) not fitted with one pair of stop lamps, or
 - b) fitted with more than two pairs of stop lamps, or
 - c) fitted with a stop lamp that is not in a pair, or
 - d) an emergency vehicle and is fitted with more than three pairs of lamps, including top-mounted lamps.
5. An emergency vehicle is fitted with:
- a) more than one pair of top-mounted lamps, or
 - b) top-mounted lamps that are not mounted as close as is practicable to the top corners of the bodywork.
6. A vehicle (eg vintage or veteran vehicle) does not meet standard stop lamp requirements, and:
- a) does not have a valid vehicle identity card with a lighting equipment endorsement, or
 - b) does not meet the conditions of the lighting equipment endorsement in its vehicle identity card.
7. A retrofitted stop lamp, other than a top-mounted lamp on an emergency vehicle, is fitted at a height from the ground exceeding 1.5m (or 2.1m where fitting below 1.5m is not practicable due to the shape of the bodywork of the vehicle).
8. A retrofitted pair of lamps is not:
- a) symmetrically mounted, or
 - b) mounted as far towards each side of the vehicle as is practicable.

Condition

9. A lamp is insecure or, if a mandatory lamp, contains moisture in the form of large droplets, runs or puddles.
10. A lens is missing, or has a hole, crack or other damage that allows moisture or dirt to enter.
11. A reflector is damaged or has deteriorated so that light output is reduced.

Performance

12. When the service brake is activated:
- a) a mandatory lamp does not operate, or
 - b) a lamp does not remain steadily illuminated.
13. A lamp operates when the service brake is not applied.
14. A lamp emits a light that is:
- a) not substantially red, or
 - b) not diffuse, or
 - c) not projected to the rear, or
 - d) not approximately equal in intensity from the other lamp in a pair, or
 - e) not bright enough to produce a light that is visible from 100m in normal daylight, eg due to modification, deterioration, dirt or an incorrect light source, or
 - f) is altered, eg due to damage or modification.
15. A non-OE mandatory lamp mounted outside the original position emits a light that is not visible within (Figure 4-10-1):

a) 15° above and below the horizontal, or

b) 45° inboard and outboard.

16. A modification to the vehicle has reduced the visibility angles of a mandatory lamp to less than (Figure 4-10-1):

a) 15° above and below the horizontal, or

b) 45° inboard and outboard.

17. An overlay has been applied that reduces or distorts the light emitted from the lamp (eg a tinted cover).

18. Where a lamp comprises an array of light sources (eg LEDs), fewer than 75% of these operate.

19. On a vehicle of American origin fitted with combined stop and direction indicator lamps, the stop lamp function is not overridden by the indicator function.

Note 1 Definitions

Modify means to change a vehicle from its original state by altering, substituting, adding or removing a structure, system, component or equipment, but does not include repair.

Repair means to restore a damaged or worn vehicle, its structure, systems, components or equipment to within safe tolerance of its condition when manufactured, including replacement with undamaged or new structures, systems, components or equipment.

Stop lamp means a lamp that is designed to operate when the service brake is activated.

Note 2

A permitted stop lamp that does not comply with equipment, condition and performance requirements must be made to comply or be disabled so that it does not emit a light.

Note 3

An original equipment (OE) lamp is one that is fitted by the vehicle manufacturer in the original position, or is an equivalent replacement or aftermarket lamp suitable for the position provided by the vehicle manufacturer for that lamp. All other lamps are considered retrofitted (ie non-OE).

Note 4

A vehicle originally manufactured with a stop lamp arrangement that differs from what is required or permitted in this section may retain the original stop lamps provided they remain fitted in their original position and perform as intended by the vehicle manufacturer.

Figure 4-10-1. Stop-lamp visibility angles

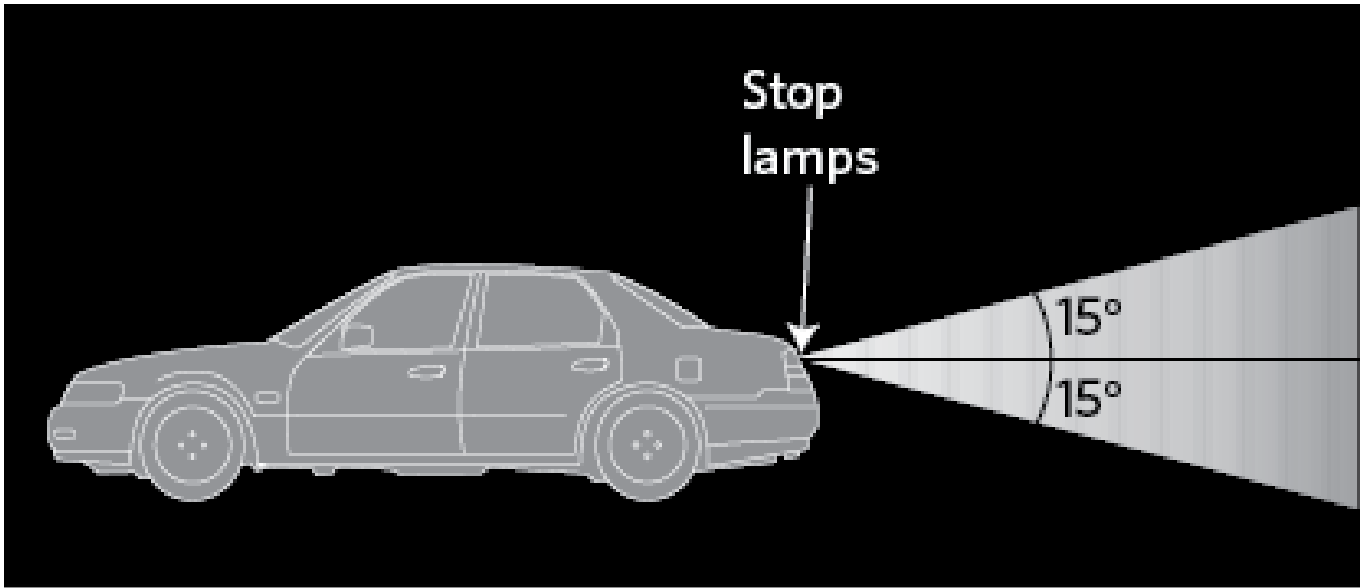

(a) Vertical angles

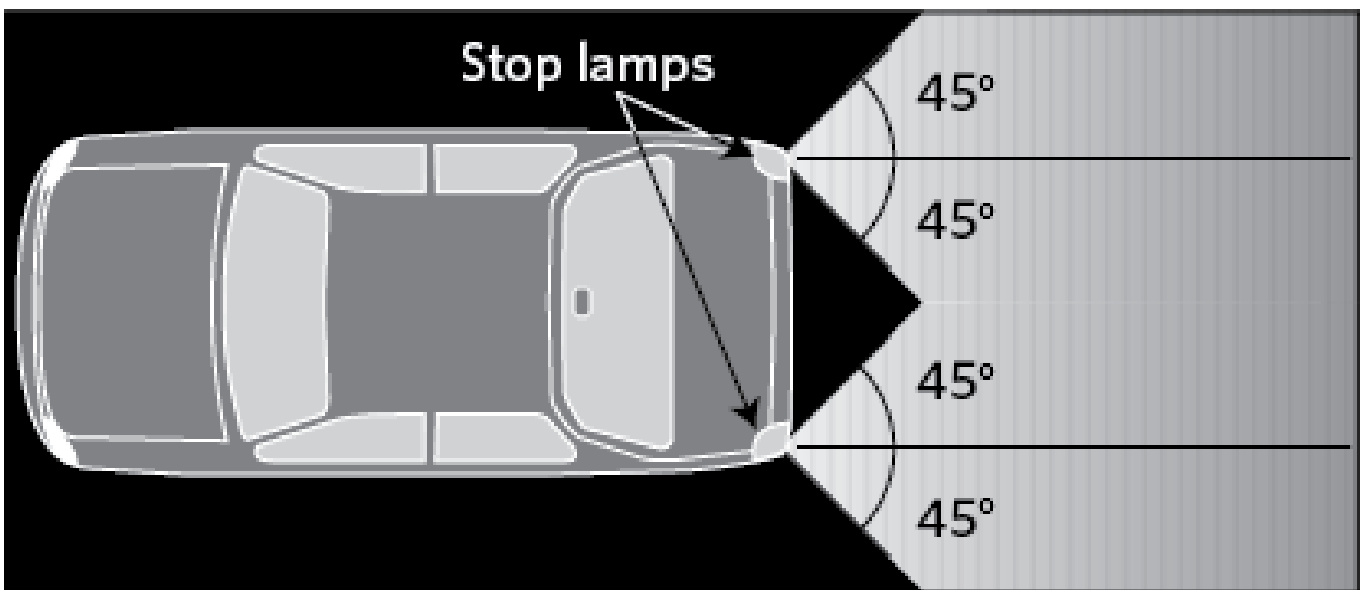

(b) Horizontal angles

Summary of legislation

Applicable legislation

- [Land Transport Rule: Vehicle Lighting 2004](#)

Mandatory and permitted equipment

1. A class LE vehicle:

a) first registered in New Zealand before 1 January 1978 may be fitted with one or two stop lamps.

b) first registered in New Zealand on or after 1 January 1978 must be fitted with one or two stop lamps

2. A group M or N vehicle:

a) first registered in New Zealand before 1 January 1978:

i. may be fitted with one, two or four stop lamps, or

ii. must be fitted with one, two or four stop lamps if its construction, equipment or loading prevents an arm signal given by the driver from being seen from behind the vehicle.

b) first registered in New Zealand on or after 1 January 1978 must be fitted with one or two pairs of stop lamps that emit a light that is visible from 100m.

3. An emergency vehicle may be fitted with an additional pair of lamps that must be symmetrically mounted as near the top corners of the bodywork of the vehicle as is practicable (top-mounted lamps).

4. A vehicle (eg a vintage or veteran vehicle) manufactured without lamps, or with lamps that cannot meet specified requirements, may obtain a WoF if:

a) the vehicle has a valid vehicle identity card with a lighting equipment endorsement, and

b) the vehicle meets the conditions of that endorsement.

5. A retrofitted pair of stop lamps must be symmetrically mounted as far towards each side of the vehicle as is practicable.

6. A retrofitted stop lamp, other than a top-mounted lamp, must be fitted at a height from the ground not exceeding 1.5m, or if this is not practicable due to the shape of the bodywork of the vehicle, not exceeding 2.1m.

7. A vehicle (eg a vintage or veteran vehicle) manufactured without lamps, or with lamps that cannot meet specified requirements, may obtain a WoF if:

a) the vehicle has a valid vehicle identity card with a lighting equipment endorsement, and

b) the vehicle meets the conditions of that endorsement.

Condition

8. A stop lamp must:

a) be in sound condition, and

b) not be obscured (if a mandatory lamp).

Performance

9. A stop lamp must operate in a way that is appropriate for the lamp and the vehicle.

10. The light emitted from a stop lamp must be diffuse light that is substantially red.

11. A required stop lamp must operate when a service brake is activated.

12. A required stop lamp must provide sufficient light output to fulfil its intended purpose.

13. A stop lamp must emit a steady light.

14. A retrofitted mandatory stop lamp must emit a light that is visible within the angles of 15° above and below the horizontal, and 45° inboard and outboard.

15. If a vehicle of American origin is fitted with combined stop and direction indicator lamps, the indicator lamps must override the stop lamps so that the stop lamps will operate as direction indicators.

16. Where a stop lamp comprises an array of light sources (eg LEDs), at least 75% of these must operate.

Modifications (Note 1)

17. A stop lamp that is affected by a modification must meet equipment, condition and performance requirements.

Page amended **2 December 2019** (see [amendment details](#)).

4-11 High-mounted stop lamps

Reasons for rejection

Mandatory and permitted equipment

1. A class MA vehicle first registered or manufactured **on or after 1 January 1990** is not fitted with one high-mounted stop lamp.
2. A vehicle is fitted with more than two high-mounted stop lamps.
3. A lamp is not fitted in a central high-mounted position.
4. A lamp fitted to a group M or N vehicle, except one that does not have a rear window, or that does not have a rear window visible from the rear, has an illuminated surface that is lower than 150mm below the bottom edge of the rear window.
5. A vehicle (eg a vintage or veteran vehicle) does not meet standard stop lamp requirements, and:
 - a) does not have a valid vehicle identity card with a lighting equipment endorsement, or
 - b) does not meet the conditions of the lighting equipment endorsement in its vehicle identity card.

Condition

6. A lamp is insecure.
7. A mandatory lamp (Note 2) is obscured, or contains moisture in the form of large droplets, runs or puddles.
8. A lens is missing, or has a hole, crack or other damage that allows moisture or dirt to enter.
9. A reflector is damaged or has deteriorated so that light output is reduced.

Performance

10. When the service brake is activated:
 - a) a mandatory (Note 2) lamp does not operate, or
 - b) a lamp does not remain steadily illuminated.
11. A lamp operates when the service brake is not activated.
12. A lamp emits a light that is not:
 - a) substantially red, or
 - b) diffuse, or
 - c) projected to the rear, or

d) bright enough to be visible from 100m in normal daylight, eg due to modification, deterioration, dirt or an incorrect light source

13. Where a lamp comprises an array of light sources (eg LEDs), fewer than 75% of these operate.

Note 1 Definitions

High-mounted stop lamp means a stop lamp that is designed to be fitted in a central, high-mounted position at the rear of a vehicle.

Stop lamp means a lamp that is designed to operate when the service brake is activated.

Note 2

Mandatory lamp – the vehicle must have one high-mounted stop lamp that meets the equipment, condition and performance requirements. Any other high-mounted stop lamp is a permitted lamp. The permitted lamp is not required to operate, but if it does operate, it must meet the equipment, condition and performance requirements, although it may be obscured.

Note 3

A vehicle originally manufactured with a high-mounted stop lamp arrangement that differs from what is required or permitted in this section may retain the original high-mounted stop lamps provided they remain fitted in their original position and perform as intended by the vehicle manufacturer.

Summary of legislation

Applicable legislation

- [Land Transport Rule: Vehicle Lighting 2004](#).

Mandatory and permitted equipment

1. A class MA vehicle first registered or manufactured **on or after 1 January 1990** must be fitted with one or two high-mounted stop lamps.
2. Any other vehicle may be fitted with one or two high-mounted stop lamps.
3. A lamp on a group M or N vehicle must be fitted in a central high-mounted position at the rear of the vehicle.
4. No part of a lamp's illuminated surface must be lower than 150mm below the bottom edge of the rear window, except where there is no rear window fitted or visible from behind the vehicle.
5. A vehicle (eg a vintage or veteran vehicle) manufactured without lamps, or with lamps that cannot meet specified requirements, may obtain a WoF if:
 - a) the vehicle has a valid vehicle identity card with a lighting equipment endorsement, and
 - b) the vehicle meets the conditions of that endorsement.

Condition

6. A high-mounted stop lamp must be in good condition.

7. At least one high-mounted stop lamp must not be obscured.

Performance

8. A high-mounted stop lamp must operate in a way that is appropriate for the lamp and the vehicle.

9. The light emitted from a high-mounted stop lamp must be diffuse light that is substantially red.

10. A high-mounted stop lamp must emit a steady light.

11. At least one unobscured lamp must operate when the vehicle's service brakes are activated.

12. Where a high-mounted stop lamp comprises an array of light sources (eg LEDs), at least 75% of these must operate.

Modifications

13. An overlay has been applied that reduces or distorts the light emitted from the lamp (eg a tinted cover).

14. A high-mounted stop lamp that is affected by a modification:

- a) must meet equipment, condition and performance requirements, and
- b) does not require LVV specialist certification.

Page amended **2 December 2019** (see [amendment details](#)).

4-12 Rear-reg.-plate illumination lamps

Reasons for rejection

Mandatory equipment

1. A vehicle is not fitted with at least one rear-registration-plate illumination lamp.

2. A vehicle (eg a vintage or veteran vehicle) does not meet standard rear-registration-plate illumination lamp requirements, and:

- a) does not have a valid vehicle identity card with a lighting equipment endorsement, or
- b) does not meet the conditions of the lighting equipment endorsement in its vehicle identity card.

Condition

3. A lamp is insecure.

4. A lens is missing, or has a hole, crack or other damage that allows moisture or dirt to enter.

5. A reflector, or lens, is damaged or has deteriorated so that light output is reduced.

Performance

6. The lamp emits a light that is not:

- a) substantially white, or
- b) steady, or
- c) diffuse.

7. The lamp does not illuminate the registration plate (eg either the lamp or plate have been moved, or the lamps orientation has been changed).

8. The light source of a lamp is visible from the rear of the vehicle.

9. An overlay has been applied that reduces or distorts the light emitted from the lamp (eg a tinted cover).

Note 1 Definitions

Rear-registration-plate illumination lamp means a lamp designed to illuminate the rear registration plate of a vehicle.

Modify means to change a vehicle from its original state by altering, substituting, adding or removing a structure, system, component or equipment, but does not include repair.

Repair means to restore a damaged or worn vehicle, its structure, systems, components or equipment to within safe tolerance of its condition when manufactured, including replacement with undamaged or new structures, systems, components or equipment.

Note 2

A vehicle originally manufactured with a rear-registration-plate illumination lamp arrangement that differs from what is required or permitted in this section may retain the original rear-registration-plate illumination lamps provided they remain fitted in their original position and perform as intended by the vehicle manufacturer.

Summary of legislation

Applicable legislation

- [Land Transport Rule: Vehicle Lighting 2004](#).

Mandatory equipment

1. At least one rear-registration-plate illumination lamp.
2. A vehicle (eg a vintage or veteran vehicle) manufactured without lamps, or with lamps that cannot meet specified requirements, may obtain a WoF if:
 - a) the vehicle has a valid vehicle identity card with a lighting equipment endorsement, and
 - b) the vehicle meets the conditions of that endorsement.

Performance

3. A rear-registration-plate illumination lamp must operate in a way that is appropriate for the lamp and the vehicle.
4. A lamp must emit a diffuse light that is substantially white.
5. A rear-registration-plate illumination lamp must emit a steady light.
6. The light source of the lamp must not be visible from the rear of the vehicle.
7. A lamp must illuminate the figures and letters of the plate so that they are visible from 20m during normal darkness.
8. Where a lamp comprises an array of light sources (eg LEDs), at least 75% of these must operate.

Modifications

9. A rear-registration-plate illumination lamp that is affected by a modification must meet equipment, condition and performance requirements.

Page amended 1 October 2021 (see [amendment details](#)).

4-13 Rear-reflectors

Mandatory and permitted equipment

1. A group M or N vehicle:
 - a) is not fitted with at least one red rearward-facing reflector on each side, or
 - b) is fitted with a red rearward-facing reflector that is not in a pair.
2. A class LE vehicle is not fitted with at least one red rearward-facing reflector.
3. A reflector is not positioned to the rear of the vehicle.
4. A retrofitted reflector is fitted at a height from the ground exceeding 1.5m (or 2.1m where fitting below 1.5m is not practicable due to the shape of the bodywork of the vehicle).
5. A retrofitted pair of reflectors is not:
 - a) symmetrically mounted, or
 - b) mounted as far towards each side of the vehicle as is practicable.

Condition

6. A mandatory reflector's ability to reflect light is affected by excessive:
 - a) fading, or
 - b) scratching or other damage.
7. A mandatory reflector is obscured.

Performance

8. The reflected light from a mandatory reflector is not visible from 100m.
9. A rearward-facing reflector on a vehicle reflects white light shining on it as anything other than red light (this does not apply to reflective material such as conspicuity/reflective tape).
10. The reflected light from a reflector is not red.
11. An overlay has been applied that reduces or distorts the light emitted from the lamp (eg a tinted cover).

Figure 4-13-1. Reflector vs reflective material



Note 1 Definitions

Reflector means a distinct item of lighting equipment that is designed to reflect incident light back towards the light source, but does not include reflective material (such as reflective tape).

Reflective material means any material that is designed to reflect incident light back towards the light source and includes reflective tape, but does not include a reflector.

Note 2

A vehicle originally manufactured with a rear reflector arrangement that differs from what is required or permitted in this section may retain the original rear reflectors provided they remain fitted in their original position and perform as intended by the vehicle manufacturer.

Summary of legislation

Applicable legislation

- [Land Transport Rule: Vehicle Lighting 2004.](#)

Mandatory and permitted equipment

1. A group M or N vehicle must be fitted with at least one pair of rearward-facing reflectors at a height from the ground not exceeding 1.5m, or if this is not practicable due to the shape of the bodywork of the vehicle, not exceeding 2.1m.
2. A class LE vehicle must be fitted with at least one rearward-facing reflector that reflects light that is visible from 100m.
3. A rearward-facing reflector must be positioned to the rear of the vehicle.
4. A reflector must be of an area that allows it to reflect light to improve the visibility of the vehicle to other road users, but it must not cause them undue dazzle or discomfort.
5. A retrofitted pair of reflectors must be symmetrically mounted as far towards each side of the vehicle as is practicable.

Condition

6. A mandatory reflector must be in good condition and not be obscured.

Performance

7. A reflector must operate in a way that is appropriate for the reflector and the vehicle.

8. A reflector must reflect white light as substantially red light.

9. A reflector must provide sufficient light reflection to fulfil its intended purpose.

Modifications

10. A rear reflector that is affected by a modification:

- a) must meet equipment, condition and performance requirements, and
- b) does not require LVV specialist certification.

Page amended 2 December 2019 (see [amendment details](#)).

4-14 Reversing lamps

Reasons for rejection

Permitted equipment

(see Note 2)

1. A vehicle is fitted with more than two reversing lamps at the rear of the vehicle.
2. A retrofitted pair of reversing lamps is not:
 - a) symmetrically mounted, or
 - b) mounted as far towards each side of the vehicle as is practicable.

Condition

(see Note 2)

3. A lamp is insecure.
4. A lens is missing, or has a hole, crack or other damage that allows moisture or dirt to enter.
5. A reflector is damaged or has deteriorated so that light output is reduced.

Performance

(see Note 2)

6. A lamp controlled by gear engagement continues to display a light to the rear when the reverse gear is disengaged.
7. A lamp controlled by a manual switch continues to display a light to the rear while the headlamps are switched on.
8. When engaged, a lamp emits light that is not:
 - a) substantially white (Note 3), or
 - b) steady, or

c) diffuse or a dipped beam.

9. Where a lamp comprises an array of light sources (eg LEDs), fewer than 75% of these operate.

Note 1 Definitions

Reversing lamp means a lamp designed to illuminate the area behind the vehicle while it is reversing and to warn other road users that the vehicle is reversing or about to reverse.

Note 2

A reversing lamp that does not comply with equipment, condition and performance requirements must be made to comply or be disabled so that it does not emit a light.

Note 3

Vehicles first registered in New Zealand before 27 February 2005 were allowed to use rear indicator lamps as reversing lamps. Although the light emitted is amber rather than white, this arrangement is still permitted for these vehicles.

Note 4

A vehicle originally manufactured with a reversing lamp arrangement that differs from what is required or permitted in this section may retain the original reversing lamps provided they remain fitted in their original position and perform as intended by the vehicle manufacturer.

Summary of legislation

Applicable legislation

- [Land Transport Rule: Vehicle Lighting 2004](#).

Permitted equipment

1. One or two reversing lamps fitted at the rear of the vehicle.
2. A retrofitted pair of reversing lamps must be symmetrically mounted as far towards each side of the vehicle as is practicable.

Condition

3. A reversing lamp must be in good condition.

Performance

4. A reversing lamp must operate in a way that is appropriate for the lamp and the vehicle.
5. A reversing lamp, when operated, must emit a diffuse light or a dipped beam of light that is substantially white (Note 3).
6. A reversing lamp must emit a steady light.

7. A reversing lamp may operate only when the reverse gear is engaged or the headlamps are turned off.
8. Where a reversing lamp comprises an array of light sources (eg LEDs), at least 75% of these must operate.

Modifications

9. A reversing lamp that is affected by a modification:
 - a) must meet equipment, condition and performance requirements, and
 - b) does not require LVV specialist certification.

4-15 Other lighting

Reasons for rejection

Permitted equipment

1. A cosmetic lamp (ie one not listed in Table 4-15-1) that is fitted to a vehicle:
 - a) has a part of its light-emitting surface positioned within 250mm of any mandatory lamp, or
 - b) is not mounted in a fixed position, or
 - c) is positioned so that its light-emitting surface is visible within the shaded areas in Figure 4-15-1.
2. A work lamp that is fitted to a vehicle is wired in such a way that the switch or circuit for any mandatory or optional lamp controls it.

Performance

3. When switched on, a cosmetic lamp with a light-emitting surface not visible within the shaded areas in Figure 4-15-1 emits a light that:
 - a) is not diffuse, or
 - b) flashes or otherwise varies in intensity or colour, or
 - c) revolves, rotates or otherwise moves, or
 - d) is too bright and likely to dazzle other road users, or
 - e) is likely to cause confusion about the orientation of the vehicle, or
 - f) is red when seen directly from the front, or
 - g) is not red or amber when seen directly from the rear.
4. A forward-facing reflector on a vehicle reflects white light shining on it as anything other than white or amber light.
5. A side-facing reflector on a vehicle reflects white light shining on it as anything other than white or amber light.

Note 1

A rear or side cosmetic lamp that does not comply with requirements for condition or performance must be made to comply, or be disabled so that it does not emit a light.

Note 2 Definitions

Lamp means a device designed to emit light, and includes an array of separate light sources that appear as a continuous illuminated surface.

Work lamp means a high-intensity lamp that is not necessary for the operation of the vehicle but is designed to illuminate the area or scene and include scene lamps, spot lamps and alley lamps.

Scene lamp means a work lamp designed to provide a fixed or movable beam of light to illuminate the area around the vehicle or the vehicle itself.

Alley lamp means a work lamp designed primarily to provide a fixed or movable beam of light to the side of the vehicle it is fitted to.

Reflective material (or **retroreflective material**) means any material that is designed to reflect incident light back towards a light source or in a specific direction; but does not include a reflector.

Cosmetic lamp means any lamp that is not listed in Table 4-15-1.

Note 3

A forward-facing cosmetic lamp that does not comply with the equipment, condition and performance requirements must be made to comply or be removed from the vehicle.

Table 4-15-1. Lamps that are not cosmetic lamps

Lamps covered in the VIRM	Other lighting equipment not requiring inspection
Headlamps Stop lamps High-mounted stop lamps Direction indicator lamps Position lamps (includes side-marker lamps and end-outline marker lamps) Rear-registration-plate illumination lamps Rear reflectors Fog lamps Daytime running lamps Cornering lamps Reversing lamps PSV interior lamps Work lamps	Interior lamps <i>Designed to illuminate the interior of the vehicle for the convenience of passengers</i> Flashing or revolving beacons Illuminated vehicle-mounted signs <i>Includes PSV destination signs, taxi signs and variable message signs operated by enforcement officers, under a traffic management plan or permitted by other legislation</i> A light source that is a necessary part of equipment required or permitted by any enactment to be fitted to a vehicle <i>Includes LEDs that indicate status on eRUC labels</i>

Figure 4-15-1. Visibility angles for cosmetic lamps

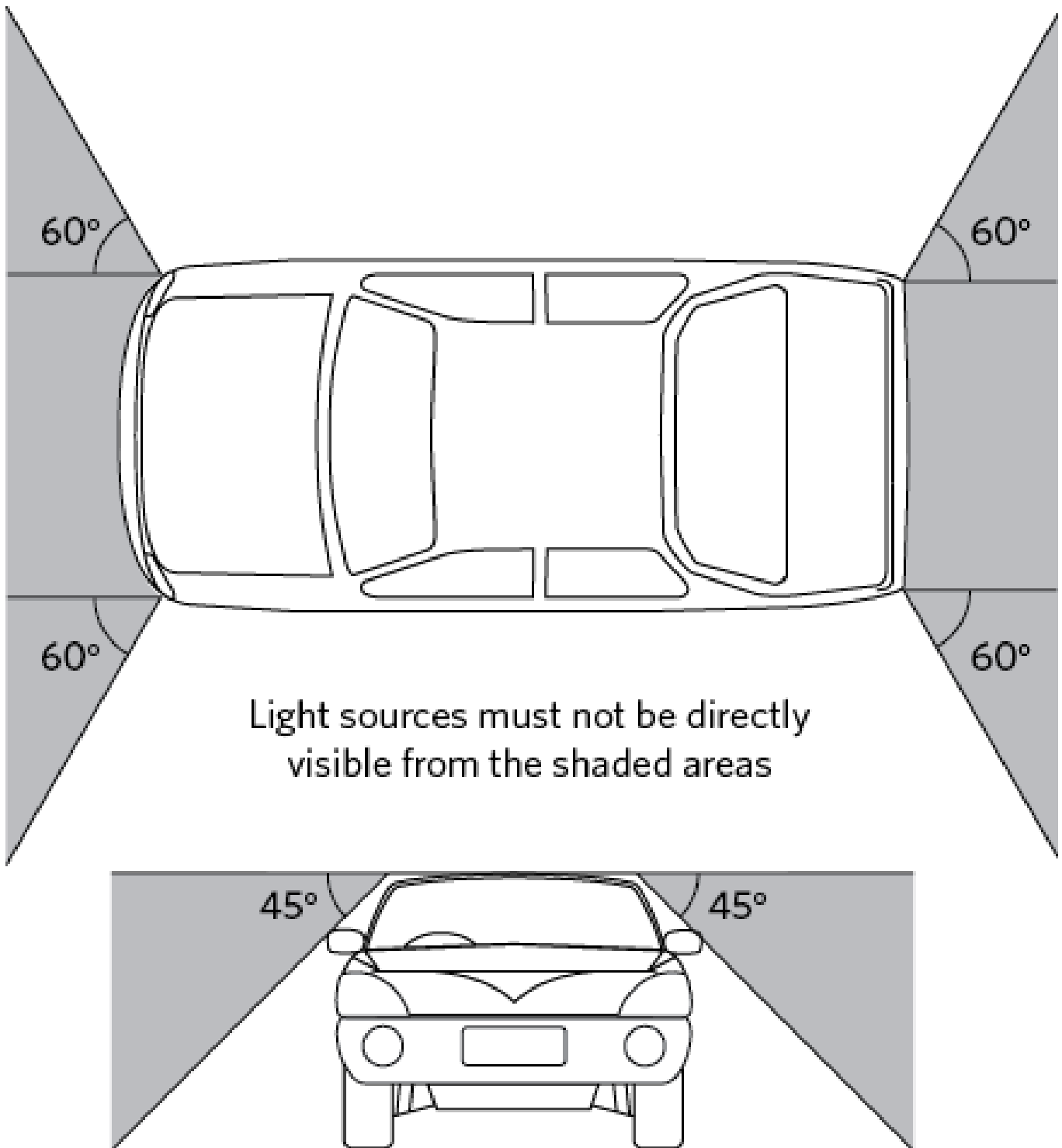

Summary of legislation

Applicable legislation

- [Land Transport Rule: Vehicle Lighting 2004.](#)

Permitted equipment

1. A vehicle may be fitted with one or more lamps not specified in Table 4-15-1, provided they are fitted so that light sources are not visible in those regions specified in Figure 4-15-1.
2. A **cosmetic** lamp must be fitted in a fixed position on the vehicle and positioned so that no part of the light source is situated within 250mm of a mandatory lamp.
3. A work lamp fitted to a vehicle must be wired in such a way that the switch or circuit for any mandatory lamp does not control it.
4. A vehicle may be fitted with reflective material to improve the visibility of the vehicle to other drivers and other road users, but the material must not dazzle, confuse or otherwise endanger their safety.

Performance

5. A **cosmetic** lamp must:
 - a) only emit light that is diffuse, and
 - b) not emit light that flashes or otherwise varies in intensity or colour, and
 - c) be fitted in a way, and be of a luminance that ensures, that it does not dazzle, confuse or distract other road users, and
 - d) not emit a light that revolves, rotates or otherwise moves, and
 - e) not cause confusion as to the orientation of the vehicle, and
 - f) not emit a red light that is directly visible from the front of the vehicle, and
 - g) not emit a light other than red or amber if the light is directly visible from the rear of the vehicle.
6. A forward-facing reflector on a vehicle must reflect white light shining on it as white or amber light.
7. A side-facing reflector on a vehicle must reflect white light shining on it as white or amber light.

Page amended **1 November 2018** (see [amendment details](#)).

4-17 PSV interior lighting

Reasons for rejection

1. An interior light for the purpose of illuminating a doorway, aisle or step:
 - a) does not function, or
 - b) interferes with the driver's vision when the doors are closed.

Summary of legislation

Applicable legislation

- [Land Transport Rule: Passenger Service Vehicles 1999](#).

Condition and performance

1. Interior lights must be positioned so that they adequately illuminate doorways, aisles and steps, but without interfering with the driver's vision when the doors are closed.

5 Vision

5-1 Glazing

Reasons for rejection

Mandatory equipment

Glazing markings (windcreens and flat glass only) – visual inspection

- Only windcreens and flat glass are required to be inspected for standards markings at in-service inspection. Flat glass is any glazing that is flat edge to edge (like typical housing window glass) in every direction ie a straight edge would sit flush on the glass in every possible position.
1. A glazing marking is not permanent, except for glazing marked by a vendor or installer, and fitted in a vehicle before 1 January 1997, which may be marked by means of a self-adhesive label.
 2. A glazing marking required in Table 5-1-1 or Table 5-1-2 is missing, except for:
 - a) plastic glazing behind the driver's seat in a soft-top convertible, or
 - b) hard plastic material behind the driver's seat in a vehicle manufactured before 1 January 1991, or
 - c) wire glass fitted to a window behind the driver's seat of a dangerous goods vehicle, or
 - d) markings on any isolation shield (see Table 5-1-6) (Note 7).
 3. The glazing has an incorrect marking for the location in which it is fitted.
 4. Glazing that is marked by a vendor or installer does not contain (Table 5-1-3 and Figure 5-1-3):
 - a) wording, characters or symbols that indicate the approved vehicle standard, and
 - b) the type of glazing, and
 - c) the thickness of the glazing in millimetres, or, in the case of laminated glass only, the thickness of the intervening layer of plastic, and
 - d) the identity of the vendor or installer of the glazing.

Glazing condition

5. A piece of glazing is not mechanically sound, or is not securely affixed to the vehicle.
6. A windscreen or front side window is so dirty or obstructed that the driver's vision is impaired.
7. A windscreen has damage that prevents the wiper blades from working properly.
8. A windscreen has scratches, discolouration or other defects that unreasonably impair the driver's vision or compromise the strength of the windscreen.

Condition within the critical vision area (CVA)

9. The critical vision area (CVA) of a windscreen (Figure 5-1-4) is damaged (apart from scratching, surface pitting, small stone marks and certified visible repairs that do not affect the driver's vision).

Condition outside the CVA

10. A windscreen has damage (Note 2) of the types and exceeding the dimensions in Table 5-1-5.

11. Any damage that extends through more than one layer of glass.

Glazing performance

12. The overall visible light transmittance (VLT) (Note 3) of a windscreen is less than 70%.

13. The overall VLT of a front side window is less than 35% (see also Figure 5-1-6 for minimum VLT limits for modified glazing (tinted overlays) for different vehicle classes).

14. Glazing has a mirrored effect sufficient to dazzle other road users (unless it is OE and has an approved standard marking).

Permitted modifications

15. A modification that affects glazing is not within the limits in Table 5-1-6.

Glazing removal

16. OE glazing that affects the structural integrity of the vehicle (eg bonded glazing) has been permanently removed but the vehicle has not been certified to the LVV Code and is not fitted with a valid LVV certification plate, the operator is not able to produce a valid modification declaration or authority card, or the vehicle has not been certified to an accepted overseas system as described in [Technical bulletin 13](#).

Condition of modified glazing

17. Glazing has scratches or other defects that unreasonably impair vision or compromise the strength of the glazing.

Performance of modified glazing

18. A modification:

- a) unreasonably impairs the driver's vision through the windscreen or a front side window, or
- b) adversely affects the strength or mechanical performance of the glazing or the vehicle.

Windscreen repair

19. A windscreen that has been rejected for a WoF or CoF has been repaired and re-presented without the required documentation (Note 6).

Note 1 - Definitions

Windscreen means all glazing extending across the front of a vehicle that is not parallel to the vehicle's longitudinal centreline, but does not include a wind deflector. No fitting of overlays or stickers are permitted to the windscreen except those previously mentioned.

Laminated glass means glazing consisting of two or more pieces of sheet glass, plate glass or float glass bonded together by one or more intervening layers of plastic material.

Overlay means a transparent, translucent or opaque self-adhesive or clinging film that is applied to large areas, or the whole, of a piece of glazing, including anti-glare band overlays, stoneguard overlays.

Sticker means a self-adhesive or clinging film, with or without print on it, that is applied for purposes such as, but not limited to, advertising, identification, information, or for aesthetic or legal reasons.

Anti-glare band overlay means a tinted overlay that is transparent and that is applied along the top edge of the windscreen for the purpose of reducing glare from the sun.

Stoneguard overlay means a clear overlay that is transparent and that is applied along the bottom edge of the windscreen for the purpose of preventing damage to the windscreen from stones and other debris thrown up by other vehicles.

Note 2

Damage includes any unrepaired damage and attempted visible repairs **that unreasonably impair the driver's vision.**

Note 3

Visible light transmittance (VLT) is the proportion of visible light that passes through glazing, measured perpendicular to the glazing. Overall VLT is the VLT of the glazing together with any overlays.

Note 4

Any OE opaque edging (usually black) is not considered part of the windscreen when determining the boundaries of the CVA, or the areas permitted for stickers, print on an anti-glare band, or radio antennae.

Note 5

Perforated overlays are usually made from printed-on materials. They are therefore not transparent and may be fitted only where stickers are allowed.

Note 6

When a windscreen has been rejected for a WoF or CoF, repaired, and then re-presented for inspection, the repair must be certified to AS/NZS 2366: 1999, AS 2366-1990 or NZS 5470: 1993. Proof of certification is the receipt issued in accordance with the relevant standard by the repairer. For AS/NZS 2366: 1999, the windscreen repair invoice must include:

- a) invoice number
- b) date of repair
- c) date of invoice (if different from date of repair)
- d) trading name and address of repairer
- e) name or identification of person performing the repair
- f) make of vehicle
- g) registration number of vehicle, or if registration number is unavailable then the vehicle identification number (VIN) or chassis number

h) details of work carried out

i) type and location of repaired damage on the windscreen (it is recommended that this be marked on a schematic windscreen on the invoice form)

j) in the case of repairs performed to this standard, a statement that the repairs have been made in accordance with and comply with AS/NZS 2366.1 using a repair system that complies with AS/NZS 2366.2

k) any guarantees or warranties given.

Note 7

NZTA makes no representations about the effectiveness of these installations, whether they are required, or whether they are sufficient for the purposes of meeting health and safety or other requirements. It takes no responsibility for the installation and use of isolation shields.

Note 8

A tolerance of 5% is permitted for the visible light transmittance (VLT) reading, to compensate for variations in tint film and light meters.

Table 5-1-1. Required markings for windscreens

- see Note 1

Date of manufacture					
Vehicle class	before 1/1/60	1/1/60–1/7/86	1/7/86–1/1/91	1/1/91–1/7/97	from 1/7/97
MA, MB, MC, NA	–	Safety glass with approved trade name or approved standard	Laminated glass with approved standard	Laminated glass with approved standard	Laminated glass with approved standard
MD1, MD2	–	Safety glass with approved trade name or approved standard	Safety glass with approved standard	Safety glass with approved standard	Laminated glass with approved standard
Low volume vehicles	–	–	–	LVV Code	LVV Code

Table 5-1-2. Required markings for other glazing

Vehicle class	Date of manufacture		
	before 1/2/77	1/2/77–1/1/91	from 1/1/91
MA, MB, MC, NA, MD1 ¹ , MD2 ¹	–	Safety glass with approved trade name or approved standard	Safety glass with approved standard
Low volume vehicles	–	–	LVV Code





¹ Curved scenic skylights above the cant rail, curved windows at front and rear corners, skylights, louvres and interior partitions may be made of a transparent material of a kind that does not shatter. This material is not usually marked.

Table 5-1-3. Approved trade names for glazing

Armourfloat	Hankuk Glass Safety Heat	Plexite	Temperlite
Armourplate	Line	Safetyflex	Temperlite Santa Marina
Blindex	HMC Glass Safety Hankuk	Safety MGB (Meloplate)	Thorex Connex
Duolite Safety	TF5	Safety MGB (Melite Safety	Triplex
Duplicate Safety	HMC Glass Safety Hankuk	Plate)	Triplex Plate
Flolite	TV5	Sekurit	Tuflite
Ford Indestructo	Indestructo	Sigla	Tyneside
Ford Safety Glass	Nippon Safety	Spectrofloat Splintex	Veracetex
Ford Silver Arrow	NM Laminated Safety Glass	Sunmat	
Glacetex	FHP	Suntex Safety Glass	
	Peerless		

Table 5-1-4. Glossary of codes for safety glass (including laminated glass)

- see Note 1, Note 4, Figure 5-1-1

L	laminated glass
F	float glass
P	plate glass
LF	laminated float
LP	laminated plate
V	toughened, VLT <70%, when near the  mark
/	toughened, when near the  mark
// or ///	laminated, when near the  mark
TS	toughened glass
TP	toughened plate
T	toughened or tempered
Z	zone tempered
HP	high performance laminated safety glass
WHP	complies with impact test (windscreen high performance laminated safety glass)
DOT	Department of Transport (USA)
AS  1 or AS up-arrow 2	the glass, in the direction of the arrow, complies with the 70% light transmission requirement
ANSI	American National Standards Institute

FMVSS codes	
AS1	for use anywhere in the vehicle
AS2	for use anywhere in the vehicle other than windscreen
AS3	for rear and rear side windows only
AS4 and AS5	for glazing not used for driver's vision (eg the rear window of heavy truck cabs or convertible tops, windows/doors in motorhome bodies, ute canopies, rear windows on buses, roof glazing etc)
Glazing cut from mother sheet	
L.76WHP	laminated, 0.76 mm interlayer, suitable for all locations
L.38	laminated, 0.38 mm interlayer, must not be used for windscreens
PCZ26.1	polycarbonate, meets requirements of ANSI Z26, must not be used for windscreens

Table 5-1-5. Types and maximum sizes of windscreen damage (outside the CVA)

- see Note 2, Figure 5-1-5









CRATER  Maximum diameter 5 mm	HORSESHOE  Maximum diameter 25 mm	STAR  Maximum diameter 30 mm	BULLSEYE  Maximum diameter 20 mm	CRACK  Maximum diameter 100 mm
COMBINATION SAME TYPE  Diameter of the smallest circle around all incidences is measured and maximum diameter applied.	COMBINATION DIFFERENT TYPES  Each type measured and maximum diameter applied separately.	COMBINATION SAME + DIFFERENT  Diameters of the smallest circles around all incidences of same types are measured and maximum diameter applied.		

Table 5-1-6. Permitted modifications

Fitting of or modification to:	Modification permitted provided that:
<p>Isolation shields (to separate vehicle occupants for the purpose of medical isolation) (Note 7)</p>	<p>The shield:</p> <ul style="list-style-type: none"> • is constructed from a transparent flexible thin film (minimum 80% VLT), and • does not interfere with the driver’s vision (including through the front side windows, and rear-view mirrors), and • does not interfere with the operation of airbags, and • does not interfere with the driver’s ability to reach vehicle controls (including lights, warning devices, etc.), and • is fastened to the vehicle using flexible/breakaway fixings that are unlikely to injure a vehicle occupant, and • can be quickly and easily removed to allow for emergency access or exit of the vehicle. <p>(Note: the partition/shield should be able to be removed, or broken, with a reasonable push or strike to allow both the driver and passenger/s to use an alternative exit in the event of an emergency.)</p>
<p>Overlays (Note 1):</p> <p>See below for overlays on windscreens, front side windows, rear and rear side windows, and sun roofs</p>	<ul style="list-style-type: none"> • overlays do not: <ul style="list-style-type: none"> – have any bubbling or other defect that could unreasonably impair vision, or – have a mirrored effect that is sufficient to dazzle other road users, or – affect the performance of any high-mounted stop lamp fitted to the vehicle.
<p>Windscreens:</p>	

Fitting of or modification to:	Modification permitted provided that:
Stickers (Note 1)	<ul style="list-style-type: none"> • stickers are wholly within 100mm of the top or bottom edge, or 50mm of the side edges (Note 4), unless required or permitted by legislation, eg: <ul style="list-style-type: none"> – a licence label – a road user licence label – a WoF label – an alternative fuel sticker – a current parking permit or other document issued by the local authority – learner L-plates (in sticker format) provided the driver's vision is not unreasonably affected.
Anti-glare band overlay (Note 1)	<ul style="list-style-type: none"> • the overlay is transparent, and • the overlay does not extend below the bottom edge of the vehicle's OE sun visors when they are folded down as far as possible towards the windscreen, and • the overlay does not contain print below a line that is 100 mm below and parallel to the top edge of the windscreen (Note 4).
Clear or transparent stoneguard overlay (Note 1)	<ul style="list-style-type: none"> • the vehicle is not of class MA or MC, and • the overlay is applied only to the bottom edge of the windscreen, and • the top edge of the overlay does not extend any higher than the highest point of the steering wheel.
Radio antennae	<ul style="list-style-type: none"> • antennae are wholly within 100mm of any edge (Note 4).
Front side windows:	
Transparent overlays (Note 5)	<ul style="list-style-type: none"> • the overall visible light transmittance (VLT) is not reduced to below 35% (Note 8).
Stickers	<ul style="list-style-type: none"> • stickers are wholly within 100mm of the bottom edge, or 50 mm of any other edge, unless required or permitted by legislation.

Fitting of or modification to:	Modification permitted provided that:
Radio antennae	<ul style="list-style-type: none"> • antennae are wholly within 100mm of any edge.
Window ports or hatches	<p>The hatch is fitted in a class ME vehicle; and</p> <ul style="list-style-type: none"> • The glazing in the hatch either meets an approved standard OR is made of a shatter proof polycarbonate or acrylic material, and • the glazing has a VLT of not less than 35% (Note 8), AND • the hatch and its frame: <ul style="list-style-type: none"> ◦ does not unreasonably interfere with the driver's vision, and ◦ is minimised in size and located to have as little impact on vision as possible (Note 1), and ◦ is rigid, sturdy, secure and water tight, and ◦ the original glazing maintains the correct and original compliant markings <p>Note: A typical compliant hatch will have a frame with a thickness ?40mm and a total area ?0.12m²</p>
<p>Rear and rear-side windows (behind the driver's seat) –</p> <p>class MA vehicles except stretch limousines and body transfer vehicles:</p>	
Transparent overlays (Note 5)	<ul style="list-style-type: none"> • the overall visible light transmittance (VLT) is not reduced to below 35% (Note 8), and • the vehicle is equipped on both sides with external rear-view mirrors.
Stickers	<ul style="list-style-type: none"> • the stickers are wholly within 100mm of any edge unless they are: <ul style="list-style-type: none"> ◦ required or permitted by legislation ◦ required for motorsport purposes (such as competition numbers or competitor names), and the vehicle has a valid motorsport authority card .
Radio antennae	<ul style="list-style-type: none"> • antennae are wholly within 100mm of any edge.
<p>Rear and rear-side windows (behind the driver's seat) –</p> <p>any vehicle class except MA, but including stretch limousines and body transfer vehicles:</p>	
Overlays and other modifications	<ul style="list-style-type: none"> • the vehicle is equipped on both sides with external rear-view mirrors.

Fitting of or modification to:	Modification permitted provided that:
Stickers	<ul style="list-style-type: none"> stickers may be applied anywhere on the glazing but, if not wholly within 100mm of any edge (Note 4), the vehicle must be equipped on both sides with external rear-view mirrors.
Radio antennae	<ul style="list-style-type: none"> in-service requirements for condition and performance are met.
Fitting of or modification to:	Modification always permitted:
Monsoon shields	<ul style="list-style-type: none"> in-service requirements for condition and performance must be met.
Electric demisters	
Sunroofs (overlays and stickers applied anywhere on the glazing, radio antennae, and electric demisters)	
Any modification for the purposes of law enforcement or the provision of emergency services	

Figure 5-1-1 Approved standards markings



Procedure – CR1

- A. JAPANESE IMPORTED COMMERCIAL VEHICLES ONLY – including Japanese imported heavy trailers:**
Please send items A1 and A2 to: →

A1. A completed Chassis Rating Request Form (form CR2 (powered vehicles) or CR3 (trailers)) below or overleaf. This must be completed using details taken directly from the vehicle.

NZ Transport Agency
Private Bag 6995
Wellington 6141
Rating type A
Fax: 04 496 6981

A2. A copy of the Japanese de-registration or export certificate.

- B. NON-JAPANESE IMPORTS – Including heavy trailers**
Please send items B1 and B2 (together) to: →

B1. Evidence of the vehicle manufacturer's chassis Ratings*, from one of the following sources:

- (a) **[North American, United Kingdom or European vehicles]** A certified** copy or photograph of the manufacturer's chassis rating plate, or (overseas) loading certificate located on the vehicle, or;

- (b) **[Other vehicles]**

A letter or other document detailing the chassis ratings* as applicable (Maximum axle and/or axle-set masses, GVM, GCM, MTM unbraked, MTM braked) from the vehicle's manufacturer, or from the manufacturer's representative in New Zealand.

NZ Transport Agency
Private Bag 6995
Wellington 6141
Rating type A
Fax: 04 496 6981

B2. A completed Chassis Rating Request Form – As in A1 above.

- C. MODIFICATIONS TO IMPORTED HEAVY VEHICLES – including heavy trailers.**

Vehicles which have been modified after manufacture, but have not been certified in their country of origin, must be certified by a NZTA recognised category HVEC engineer. The NZTA (0800 699 000) has the contact details of such engineers in various regions of New Zealand.

* *As applicable to the vehicle concerned, means the: maximum axle and/or axle-set masses, gross vehicle mass (GVM), gross combination mass (GCM), maximum towed mass unbraked (MTM unbraked), maximum towed mass braked (MTM braked).*

** *A certified copy is a paper copy of everything off the plate, certified*



Figure 5-1-2. Typical laminated glazing markings (Note 1)





<p>DOT 266 AS1 M 4 7 1 NZS 5443 LF AS 2080 Lic 2004 W.H.P Lic 210 BS 857-2:1967  PILKINGTON New Zealand</p>	<p>LAMINATED F WHP  BS 857 Kinonglas-Kristal-FIRA/F BFB-HI DOT 31 / M 75.4 / AS 1 DGM 36593 VSP D 396</p>	<p> STADIP-V 43R-001009 M94 AS1-DOT211 E-00048 H8</p>	<p>NISSAN LAMIPANE DOT 23  LP AS1 NSG.M491</p>
---	--	---	--

Figure 5-1-3. Typical markings required on glazing cut from mother sheet

<p>a. Stickers</p>  <p><i>Note: These adhesive stickers valid only on glass cut prior to 1/1/97</i></p>	<p>b. Etched markings</p>  <p><i>Note: This labelling is required on all glass cut after 1/1/97</i></p>
--	---

Figure 5-1-4. Windscreen critical vision area (CVA)



To be measured from the inside of the vehicle from the point where the glass is visible (ie after any seals)

Stickers are allowed within the critical vision area so long as they are within 100mm from the top or bottom edge of the windscreen (see Table 5-1-6).

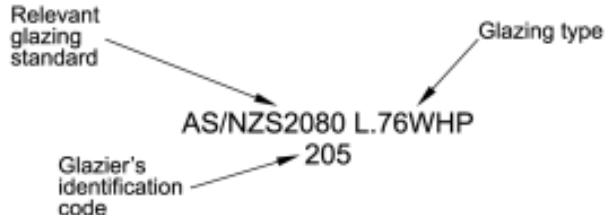
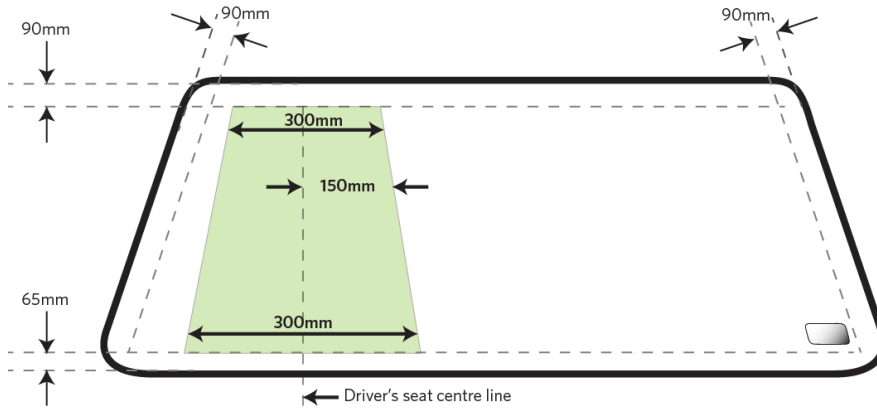
Figure 5-1-5. Actual maximum sizes of types of windscreen damage

COMBINATION DAMAGE	
<p>Combination: same type</p> <p>Diameter of the smallest circle around all incidences is measured and maximum diameter applied.</p> <p>Example: Two craters: Maximum diameter 5 mm for both craters together.</p>	<p>Combination: same + different types</p> <p>Each type is measured and maximum diameter applied separately.</p> <p>Example: Two craters + crack: Maximum diameter 5 mm for two craters; 100 mm for the crack, whichever applies.</p>
<p>Combination: different types</p> <p>Each type measured and maximum diameter applied.</p> <p>Example: Bullseye + crack: Maximum diameter 20 mm for the bullseye; 100 mm for the crack, whichever applies.</p>	

Note Due to different screen resolutions and sizes the above image may not be shown at actual size.

Figure 5-1-6. Minimum VLT limits for modified glazing (tinted overlays) for different vehicle classes

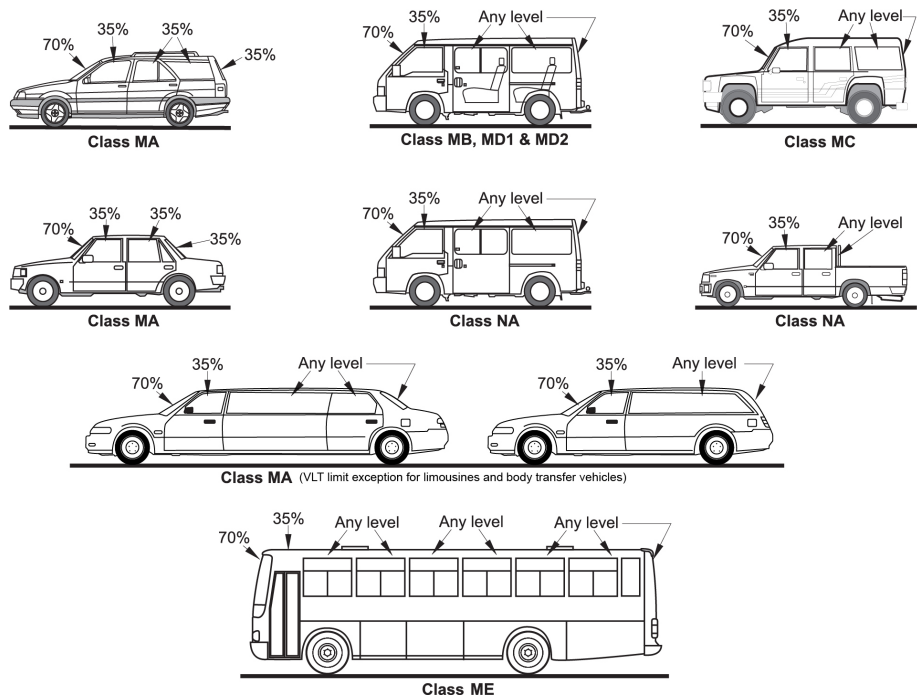

Note The minimum VLT for any windshield is 70% but no overlays may be fitted.

Summary of legislation

Applicable legislation

- [Land Transport Rule: Glazing, Windscreen Wipe and Wash, and Mirrors 1999.](#)

Mandatory equipment

Glazing markings

1. Windcreens and other glazing must be permanently and indelibly marked as complying with an approved trade name or approved vehicle standard as shown in Table 5-1-1 and Table 5-1-2 unless excluded as below:

- glazing marked by a vendor or installer, and fitted in a vehicle before 1 January 1997, may be marked by means of a self-adhesive label
- plastic glazing behind the driver's seat in a soft-top convertible need not be marked
- hard plastic material behind the driver's seat in a vehicle manufactured before 1 January 1991 need not be marked.

2. Glazing marked by the vendor or installer must contain wording, characters or symbols that indicate the approved vehicle standard, and the:

- type of glazing, and
- thickness of the glazing in millimetres or, in the case of laminated glass only, the thickness of the intervening layer of plastic, and

c) identity of the vendor or installer of the glazing.

Permitted glazing

3. Wire glass may be used in any window behind the driver's seat, if required or allowed under any legislation.

4. Vehicles of class MD1 or MD2 may be fitted with the following, which may be made of a transparent material of a kind that does not shatter:

- a) curved scenic skylights above the cant rail
- b) curved windows at the front and rear corners
- c) skylights
- d) louvres
- e) interior partitions.

Glazing condition

5. Glazing must be mechanically sound, strong, and securely affixed to the vehicle.

6. A windscreen and front side windows must be clean and free of obstruction to ensure the driver has sufficient vision through the glazing to operate the vehicle safely.

7. A windscreen must not have scratches and other defects that:

- a) unreasonably impair vision, or
- b) compromise its strength.

8. A laminated windscreen must not show signs of discolouration that could unreasonably impair the driver's vision.

9. Glazing in roof panels may be tinted.

Glazing performance

10. A windscreen visible light transmittance (VLT) must be at least 70%.

11. Front side windows VLT must be at least 35%.

12. Glazing must not have a mirrored effect sufficient to dazzle other road users.

Permitted modifications

13. A modification that affects glazing is permitted if within the limits in Table 5-1-6.

Glazing removal

14. Permanent removal of OE-specified glazing that affects the structural integrity of the vehicle (eg bonded glazing) must be certified in accordance with the Low Volume Vehicle Code.

Condition of modified glazing

15. Overlays must not have any bubbling or other defects that could unreasonably impair vision.

16. Glazing must not have any scratches or other defects that unreasonably impair vision or compromise the strength of the glazing.

Performance of modified glazing

17. Modifications must not:

- a) unreasonably impair vision through a windscreen or a front side window, or a rear or rear side window in the case of MA vehicles other than stretch limousines or body transfer vehicles, or
- b) adversely affect the strength or mechanical performance of the glazing or the vehicle.

Windscreen repair

18. Windscreens: a repair to a windscreen carried out on or after 1 January 1997 must comply with whichever of the following standards is applicable at the date of repair:

- a) New Zealand standard 5470: 1993, Code of Practice for Automotive Windscreen Repair (superseded by Australian Standard/New Zealand standard 2366: 1999, Windscreen Repairs), or
- b) Australian standard 2366-1990, Repair of Laminated Glass Windscreens fitted to Road Vehicles (superseded by Australian Standard/New Zealand standard 2366: 1999, Windscreen Repairs).

Page amended **1 April 2023** (see [amendment details](#)).

Page updated **4 October 2023** (see [details](#)).

5-2 Sun visors

Reasons for rejection

Mandatory equipment

1. A sun visor for the driver's use is not fitted to a vehicle (other than of class LE) which can practicably be fitted with a sun visor (Note 1).

Condition

2. A sun visor:

- a) is insecurely mounted, or
- b) for the driver, cannot be adjusted from the normal driving position, or
- c) cannot maintain its adjusted position, or
- d) has been modified or has deteriorated, and the likelihood of injury to vehicle occupants has not been minimised.

Performance

3. A driver's sun visor does not effectively aid the driver's vision by intercepting the glare from the sun.

Note 1 Definitions

Sun visor means any attachment mounted above the inside of the windscreen and provided for the purpose of shielding the eyes of the driver and other front seat passengers from solar glare.

Modify means to change a vehicle from its original state by altering, substituting, adding or removing a structure, system, component or equipment, but does not include repair.

Repair means to restore a damaged or worn vehicle, its structure, systems, components or equipment to within safe tolerance of its condition when manufactured, including replacement with undamaged or new structures, systems, components or equipment.

Summary of legislation

Applicable legislation

- [Land Transport Rule: Vehicle Equipment 2004](#)
- [Land Transport Rule: Interior Impact 2002](#).

Mandatory equipment

1. A vehicle other than of class LE must be fitted with a sun visor for the driver's use if it is reasonable and practicable to do so (Note 1).

Permitted equipment

2. A vehicle of class LE may be fitted with a sun visor.
3. Additional sun visors may be fitted in other positions.

Condition

4. The condition of a sun visor must be such that the likelihood of injury to occupants is minimised.

Performance

5. A driver's sun visor must be effective.

Modification

6. A sun visor that is not OE or that has been affected by a modification (Note 1):
 - a) must meet the requirements for equipment, condition and performance, and
 - b) does not require LVV specialist certification.

5-3 Windscreen wipe and wash

Reasons for rejection

Mandatory equipment

1. A vehicle that has a windscreen is not fitted with a windscreen wipe system.
2. A vehicle manufactured on or after 1 January 1992 is not fitted with a windscreen wash system.
3. A vehicle manufactured on or after 1 January 1960 is fitted with wipers that are not power driven.

Condition

Windscreen wipe system

4. The wiper operating device is missing.
5. A wiper arm or wiper blade is:
 - a) missing, or
 - b) insecure, or
 - c) damaged so as to affect the performance of the wipers.
6. The wiper operating mechanism is:
 - a) missing, or
 - b) insecure, or
 - c) damaged so as to affect the performance of the wipers.

Windscreen wash system

7. A wash system component is missing or insecure.
8. The wash operating device is missing.

Performance

Windscreen wipe system

9. A windscreen wiper does not wipe the windscreen effectively, preventing adequate forward vision by the driver.
10. The wipe operating device is unable to activate the wipe system.

Windscreen wash system

11. A windscreen wash nozzle does not discharge washer liquid directly onto the windscreen.
12. The wash operating device is unable to activate the wash system.

Modifications

13. A modification affects a windscreen wipe system, and:
 - a) is not excluded from the requirements for LVV specialist certification (Table 5-3-1), and
 - b) is missing proof of LVV specialist **or accepted overseas** certification, ie:
 - i. the vehicle is not fitted with a valid LVV certification plate, or
 - ii. the operator is not able to produce a valid modification declaration or authority card, **or**
 - iii. the vehicle has not been certified to an accepted overseas system as described in **Technical bulletin 13**.

Table 5-3-1. Modifications that do not require LVV certification

Fitting of or modification to:	LVV certification is never required:
Removal of a windscreen wash system from a vehicle manufactured before 1/1/1992	• in-service requirements for condition and performance must be met.
Any modification for the purposes of law enforcement or the provision of emergency services	

Summary of legislation

Applicable legislation

- [Land Transport Rule: Glazing, Windscreen Wipe and Wash, and Mirrors 1999](#).

Mandatory equipment

1. A vehicle manufactured before 1 January 1992 that is fitted with a windscreen must have a windscreen wipe system.
2. A vehicle manufactured on or after 1 January 1992 that is fitted with a windscreen must have a windscreen wipe and wash system.
3. Windscreen wipers must be power driven, unless they follow OE specifications in a vehicle manufactured before 1 January 1960.

Permitted equipment

4. A vehicle may be fitted with a wash system when this is not required.

Condition

5. A vehicle's windscreen wipe system must be efficient and within the vehicle manufacturer's operating limits.

Performance

6. The equipment fitted must be capable of keeping an adequate area of the windscreen clean and clear so that the vehicle may be operated safely under all reasonably foreseeable conditions.

Modifications

7. An OE windscreen washing system may be removed from a vehicle manufactured before 1 January 1992.
8. A modification to the windscreen wipe system must be inspected and certified by an LVV specialist certifier unless the vehicle:
 - a) is excluded from the requirement for LVV specialist certification (Table 5-3-1), and
 - b) has been inspected in accordance with the requirements in this manual, including those for equipment, condition, and performance.

5-4 Rear-view mirrors

Reasons for rejection

Rear-view mirror includes a camera monitor system that uses cameras that are mounted in order to have the same or a similar view as a rear-view mirror and that displays the images viewed by the camera on a monitor inside the vehicle that is visible to the driver.

Mandatory equipment

1. A mandatory rear-view mirror identified in Table 5-4-1 is missing.

Condition

2. A rear-view mirror:

- a) is not mounted securely, or
- b) cannot be adjusted, or
- c) cannot maintain its adjusted position, or
- d) is corroded or dirty, or
- e) is damaged so that it increases the risk of injury to vehicle occupants.

Performance

3. A rear-view mirror:

- a) does not provide a clear view to the rear of the vehicle, or
- b) is not sufficiently isolated from vibrations.

Modifications

4. A modification affects rear-view mirrors, and:

- a) is not excluded from the requirements for LVV specialist certification (Table 5-4-2), and
- b) is missing proof of LVV specialist **or accepted overseas** certification, ie:
 - i. the vehicle is not fitted with a valid LVV certification plate, or
 - ii. the operator is not able to produce a valid modification declaration or authority card, **or**
 - iii. **the vehicle has not been certified to an accepted overseas system as described in [Technical bulletin 13](#).**

Note 1

A vehicle with overlays on the rear side windows and rear screen must be fitted with a left-hand and a right-hand exterior mirror.

Table 5-4-1. Mandatory requirements for rear-view mirrors

For **left-hand drive** vehicles, read R/H side instead of L/H side, and L/H side instead of R/H side.

Vehicle class	Year of manufacture	
	Before 1 January 2000	From 1 January 2000
MA, MB, MC	External R/H side or interior	External R/H side and interior
NA	External R/H side or interior	External R/H side and interior or external L/H side
MD1, MD2	External R/H side and external L/H side	External R/H side and external L/H side

Table 5-4-2. Modifications that do not require LVV certification

Fitting of or modification to:	LVV certification is never required:
Additional or substituted rear-view mirrors , or removal of a non-mandatory mirror	<ul style="list-style-type: none">• in-service requirements for condition and performance must be met.
Any modification for the purposes of law enforcement or the provision of emergency services	

Summary of legislation

Applicable legislation

- [Land Transport Rule: Glazing, Windscreen Wipe and Wash, and Mirrors 1999.](#)

Mandatory equipment

1. A vehicle must be fitted with one or more of the rear-view mirrors listed in Table 5-4-1.

Permitted equipment

2. Additional rear-view mirrors may be fitted.

Condition

3. A rear-view mirror must be:
 - a) securely attached so that the risk of injury is minimised, and
 - b) mounted so that vibration does not inhibit the driver's required clear view to the rear, and
 - c) sufficiently adjustable, and able to maintain its position.

Performance

4. A rear-view mirror must provide a clear view to the rear of:

- a) the motor vehicle itself, and
- b) the vehicle's load, and
- c) any towed trailer and its load.

5. A rear-view mirror must be sufficiently isolated from vibrations.

Modifications

6. The fitting of additional rear-view mirrors, or a modification that affects rear-view mirrors, must be inspected and certified by an LVV specialist certifier, unless the vehicle:

- a) is excluded from the requirement for LVV specialist certification (Table 5-4-2), and
- b) has been inspected in accordance with the requirements in this manual, including those for equipment, condition and performance.

Page amended **1 May 2021** (see [amendment details](#)).

5-5 PSV driver's vision

Reasons for rejection

Condition and performance

1. The driver's view through the windscreen or front side window is obstructed.
2. A passenger seat is positioned so that its occupant obstructs the driver's view through the windscreen or front side windows.
3. The interior of the vehicle, except a stretch limousine, cannot be **clearly** seen by the driver either:
 - a) directly, or
 - b) indirectly using mirrors or closed-circuit cameras (Note 1).
4. **A person in the exterior vicinity of any door used by passengers cannot be clearly seen by the driver either:**
 - a) directly, or
 - b) indirectly using existing rear-view mirrors, additional mirrors, **or closed-circuit cameras**.
5. **A required closed-circuit camera has a screen that does not operate.**

Note 1

The indirect view may be provided using rear-view mirrors ([section 5-4](#)), additional mirrors, or closed-circuit cameras.

Summary of legislation

Applicable legislation

- [Land Transport Rule: Passenger Service Vehicles 1999](#).

Performance

1. The vehicle must provide the driver with a direct or indirect (Note 1) **clear** view of:
 - a) the interior of the vehicle (except for stretch limousines), and
 - b) **any person in the exterior vicinity of any door used by passengers**.
2. Seats must not be positioned where their occupants will obstruct the driver's view through the windscreen or front side windows.
3. **A closed-circuit camera system may be fitted to provide the driver with an indirect view on a television screen.**

Page amended **1 October 2012** (see [amendment details](#)).

5-6 PSV demisters

Reasons for rejection

Mandatory equipment

1. The windscreen **and** side window used by the driver is not equipped with demisting equipment.

Condition and performance

2. The demisting equipment:
 - a) does not operate, or
 - b) is ineffective, eg the air is not hot enough or there is insufficient volume, or
 - c) cannot be operated from the driver's seat.

Summary of legislation

Applicable legislation

- [Land Transport Rule: Passenger Service Vehicles 1999](#).

Mandatory equipment

1. The front windscreen and side windows used by the driver must be equipped with effective demisting equipment, adjustable from the driver's seat.

Page updated 18 July 2023 (see [details](#)).

6 Entrance and exit

6-1 Door and hinged panel retention systems

Reasons for rejection

Mandatory equipment

1. A motor vehicle fitted with doors used by the driver or passengers for entrance and exit of the motor vehicle does not have a door retention system.
2. A vehicle for transporting prisoners which does not have doors in the prison compartment that can be opened from the inside, has no alternative exit that can be operated by an authorised person in an emergency.

Equipment condition

3. A hinge for a door or other hinged panel is not securely attached to both the vehicle body and to the door or other hinged panel due to loose connections, corrosion or other damage (Note 1).
4. A latch, catch, striker or any other part of a door or hinged panel retention system is not securely attached, or is in poor condition, due to a loose connection, corrosion or other damage (Note 1).
5. A door used for entrance and exit of the driver or passengers cannot be opened from the inside, unless the vehicle is designed or adapted to transport prisoners and the door is inoperable from the inside of the prison compartment.
6. A child safety lock or similar safety device cannot be deactivated.
7. There is corrosion damage within 150 mm of the hinge of a door or other hinged panel (see Figure 6-1-1).
8. There is corrosion damage within 150 mm of the latch of a door or other hinged panel (see Figure 6-1-1).

Equipment performance

9. A door used for entrance and exit of the driver or passengers does not open or close easily.
10. A door or other hinged panel does not remain secure in a closed or locked position.

Modifications

11. A modification (Note 2) affects door or hinged panel retention systems, and:
 - a) is not excluded from the requirements for LVV specialist certification (Table 6-1-1), and
 - b) is missing proof of LVV specialist or accepted overseas certification, ie:
 - i. the vehicle is not fitted with a valid LVV certification plate, or
 - ii. the operator is not able to produce a valid modification declaration or authority card, or
 - iii. the vehicle has not been certified to an accepted overseas system as described in [Technical bulletin 13](#).

Note 1

Corrosion damage is where the metal has been eaten away, which is evident by pitting. The outward signs of such corrosion damage is typically displayed by the lifting or bubbling of paint. In extreme cases, the area affected by the

corrosion damage will fall out and leave a hole.

Note 2 Definitions

Modify means to change a vehicle from its original state by altering, substituting, adding or removing a structure, system, component or equipment, but does not include repair.

Repair means to restore a damaged or worn vehicle, its structure, systems, components or equipment, including replacement with undamaged or new structures, systems, components or equipment.

Child safety lock (also known as a kiddi-lock) means a safety device installed during the manufacture of the vehicle to prevent a door from being opened from the inside of the vehicle.

Tables and images

Table 6-1-1 Modifications that do not require LVV certification

Fitting of or modification to:	LVV certification is not required provided that:
Exterior door handles (on doors normally used for entry and exit of occupants)	<ul style="list-style-type: none"> • the modification is minor (eg removal of key locks), and • door handles remain fitted and in serviceable condition. <p>Note</p> <p>The fitting of a door opening/closing mechanism (which may include the removal of exterior door handles) that differs from original must be LVV certified.</p>
Fitting of or modification to:	LVV certification is never required:
Any modification for the purposes of law enforcement or the provision of emergency services	<ul style="list-style-type: none"> • in-service requirements for condition and performance must be met.

Figure 6-1-1 Hinge and latch anchorages

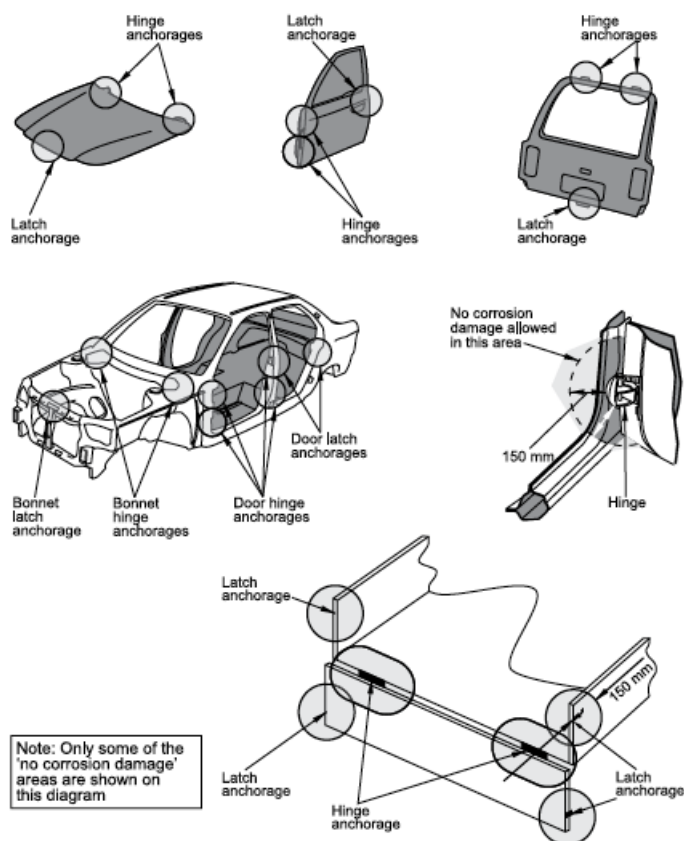

No corrosion damage is allowed within 150mm of a circle around the outside of hinge or latch components.

See also figures for corrosion limits to structure ([section 3-1](#)), seatbelt anchorages ([section 7-5](#)), and front or rear suspension anchorages ([section 9-1](#)).

Summary of legislation

Applicable legislation

- [Land Transport Rule: Door Retention Systems 2001](#)
- [Land Transport Rule: Vehicle Standards Compliance 2002, section 7.4.](#)

Mandatory equipment

1. A motor vehicle fitted with doors used by the driver or passengers for entrance and exit of the motor vehicle must have a door retention system.

Permitted equipment

2. The door retention system on doors to the rear of the driver's seat may incorporate safety devices installed during the manufacture of the vehicle to prevent the doors from being opened from the inside of the vehicle (eg child safety locks).

3. A vehicle designed or adapted to transport prisoners is not required to be fitted with a mechanism for opening a door from the inside if the prison compartment has an alternative exit that can be operated by an authorised person in an emergency.

Equipment condition

4. A door retention system and its mountings must be safe and structurally sound.
5. A door used for the entrance and exit of the driver or passengers must be operable by any occupant seated by the door from inside the motor vehicle, unless it is permitted equipment designed or adapted to operate otherwise.
6. The vehicle must be designed and constructed using components and materials that are fit for their purpose, and within safe tolerance of their state when manufactured or modified.

Equipment performance

7. A door retention system must be in good working order.
8. A door used for entrance and exit must open and close easily.
9. A door used for entrance and exit must remain secure in a closed position during the operation of the motor vehicle.

Modifications

10. A modification that affects door or hinged panel retention systems must be inspected and certified by a low volume vehicle specialist certifier, unless the vehicle:
 - a) is excluded from the requirement for LVV specialist certification (Table 6-1-1), and
 - b) has been inspected in accordance with the requirements in this manual, including those for equipment, condition and performance.

Page amended **2 December 2019** (see [amendment details](#)).

6-2 PSV doors and doorways

Reasons for Rejection

Mandatory equipment

General

1. Refer to [section 6-1](#).
2. A PSV does not have at least one doorway for passenger entry or exit on the left-hand side of the vehicle, unless it is:
 - a) an outdoor-access vehicle, or
 - b) a vehicle fitted with equipment for people with special mobility requirements.
3. An outdoor-access vehicle does not have at least one doorway for passenger entry or exit on the left-hand side or in the rear of the vehicle.
4. On a motor vehicle that entered service as a PSV on or after 1 July 2000, a door, except for a left-front door alongside and within direct line of sight of the driver, does not have a device that warns the driver if the door is not closed properly when the vehicle is stationary or driven away.

Power-operated doors

5. A motor vehicle that entered service as a PSV before 1 July 2000 that has a door which is controlled from the driver's seat does not have either:

- a) a sign by the door, in letters at least 10 mm high, which states: In an emergency use door control by the driver's seat, or
- b) emergency controls which:
 - i. are fitted on or next to the door, both inside and outside the vehicle, or
 - ii. have easy-to-understand operating instructions fitted next to them, both inside and outside the vehicle.

6. A motor vehicle that entered service as a PSV on or after 1 July 2000 that has a door which is controlled from the driver's seat does not have emergency controls which:

- a) can be operated in an emergency when the PSV is stationary, or
- b) are fitted on or next to the door, both inside and outside the vehicle, or
- c) have easy-to-understand operating instructions fitted next to them, both inside and outside the vehicle.

Condition and performance

General

7. Refer to [section 6-1](#).

8. A door locks automatically when it is closed.

9. A small passenger service vehicle (Note 2) has a speed-sensitive or other automatic central-locking device that causes any door to stay locked while the vehicle is stationary.

10. A safety device installed during the manufacture of the vehicle to prevent the doors from being opened from inside the vehicle, eg a child safety lock (Note 1), has not been removed or permanently deactivated, and

- a) an approved sign (Figure 6-2-1) is not displayed adjacent to the exterior handle of each rear side door, or
- b) the approved sign is not clearly legible, or
- c) in the case of a class MD2 vehicle, a valid exemption cannot be produced.

11. A door that is not controlled by the driver cannot be opened from outside the vehicle.

12. A doorway provided for passenger entry or exit is obstructed.

13. A device to warn the driver that the door is not closed properly:

- a) does not function correctly, or
- b) is not effective.

14. A door or doorway is in such a condition that it is likely to injure passengers entering or leaving the vehicle.

15. An emergency door control sign or operating instruction is not clearly legible.

16. An emergency door control:

- a) cannot be operated when the PSV is stationary, or
- b) does not allow the door to be operated manually in the event of a power failure, or

c) has a component that has significantly deteriorated so that its operation in an emergency is likely to be compromised.

Power-operated doors

17. A power-operated door is such that it is likely to injure or trap a person eg by excessive opening or closing force, or damage or deterioration (Note 3).

Modification

18. Refer to [section 6-1](#).

19. A door or doorway was modified since the last CoF inspection and there is no written confirmation that items affected by the modification comply with the requirements for [entry certification](#).

Note 1

Child safety lock (also known as a kiddi-lock) means a safety device installed during the manufacture of the vehicle to prevent a door from being opened from the inside of the vehicle.

Note 2

Small passenger service vehicle means a vehicle used or available for use in a passenger service for the carriage of passengers that is designed or adapted to carry 12 or fewer persons (including the driver).

Note 3

A power-operated door may be deemed acceptable in terms of potential injury or entrapment of a person due to excessive closing force if:

a) the door is located at the left-front of the vehicle within the **driver's clear view from his seat** (without using mirrors or CCTV), and is opened and closed by means of a driver-operated control, or

b) the door automatically opens when it meets an obstruction, and remains open until being closed using the driver-operated control, or

c) in the event that the door closes onto part of a person, the person can readily extract the trapped part. **For compressed air- or vacuum-operated doors only** see [Technical Bulletin 5: Door test procedure: Compressed air- or vacuum-operated doors](#).

Figure 6-2-1. Approved child safety lock sign (white text on red background)

A red rectangular sign with rounded corners and a white border. The text is white and reads: "WARNING: Door cannot be opened from inside if child safety lock is on."/>

WARNING: Door cannot be opened from inside if child safety lock is on.

Summary of legislation

Applicable legislation

- [Land Transport Rule: Passenger Service Vehicles 1999](#).

Mandatory equipment

General

1. Refer to [section 6-1](#).
2. A PSV must have at least one doorway for passenger entry or exit on the left-hand side of the vehicle, unless it is:
 - a) an outdoor-access vehicle, and a doorway for passenger entry or exit is provided in the rear, or
 - b) a vehicle fitted with equipment for people with special mobility requirements.
3. On a motor vehicle that entered service as a PSV on or after 1 July 2000, a door, except a left-front door alongside and within direct line of sight of the driver, must have a device that warns the driver if the door is not closed properly.

Power-operated doors

4. A motor vehicle that entered service as a PSV before 1 July 2000 that has a door which is controlled from the driver's seat must have:
 - a) a sign by the door, in letters at least 10 mm high, which states: In an emergency use door control by the driver's seat, or
 - b) emergency controls which:
 - i. can be operated in an emergency when the PSV is stationary, and
 - ii. are fitted on or next to the door, both inside and outside the vehicle, and
 - iii. have easy-to-understand operating instructions fitted next to them, both inside and outside the vehicle.

5. A motor vehicle that entered service as a PSV on or after 1 July 2000 that has a door which is controlled from the driver's seat must have emergency controls which:

- a) can be operated in an emergency when the PSV is stationary, and
- b) are fitted on or next to the door, both inside and outside the vehicle, and
- c) have easy-to-understand operating instructions fitted next to them, both inside and outside the vehicle.

Performance

General

6. A door and its operation must meet the requirements of [section 6-1](#), except:

- safety devices installed during the manufacture of the vehicle to prevent the doors from being opened from the inside of the vehicle (eg a child safety lock (Note 1)) must be removed or permanently deactivated (unless the vehicle is a small passenger service vehicle (Note 2) and a sign approved by NZTA is displayed at the outer door handle), and
- doors that are not controlled by the driver must be able to be opened from both inside and outside the vehicle when someone is in the vehicle except when the occupant has locked the doors, and
- a door must be operable by any occupant next to the door, from inside the vehicle.

7. A doorway provided for passenger entry or exit must be clear of obstruction.

8. A door must not lock automatically when it is closed.

9. Speed-sensitive or other automatically operating central-locking devices fitted to a small passenger service vehicle (Note 2) must not automatically cause any door to be locked while the vehicle is stationary.

Power-operated doors

10. A power-operated door must be maintained so that the opening and closing force of the door, or its method of operation, is unlikely to injure or trap any person (Note 3).

Modification

11. If a PSV doorway has been modified since it was last certified for operation in-service and the modification has affected the door's operation or the doorway dimensions, the doorway must comply with the requirements for [entry certification](#).

Page amended **1 November 2014** (see [amendment details](#)).

6-3 PSV entry and exit steps, ramps and hoists

Reasons for rejection

Mandatory requirement

1. A wheelchair ramp or hoist fitted to a PSV that entered service as a PSV in New Zealand on or after 1 July 2000, or a wheelchair ramp or hoist fitted to a PSV on or after 1 July 2000, does not have evidence of LVV specialist certification, that is the vehicle is not fitted with a valid LVV certification plate.

2. A wheelchair hoist fitted to a PSV that entered service as a PSV in New Zealand on or after 1 July 2000, or a wheelchair hoist fitted to a PSV on or after 1 July 2000, does not have evidence that it is load-rated for 300kg or more.

Condition and performance

3. An entry and exit step or ramp:

- a) does not have a slip-resistant tread surface, or
- b) does not provide safe entry or exit for occupants, eg:
 - i. the tread surface is slippery or has significantly deteriorated, or
 - ii. the structure or its attachment is loose or significantly deteriorated.

4. A ramp or retractable step does not:

- a) operate correctly, or
- b) remain secure in its retracted position or when in use.

Wheelchair hoists (Note 1)

5. A wheelchair hoist:

- a) does not operate correctly, or
- b) is not securely fitted to the vehicle, or
- c) has a component which is missing, insecure or has significantly deteriorated, or
- d) if power-operated, does not incorporate a braking function that actuates when the control device is released, or
- e) when powered down, does not have a device that prevents jacking of the vehicle, or
- f) if side-mounted, does not have a means of warning the driver when the hoist is not stowed, or
- g) has moving parts which touch the vehicle during the raising/lowering cycle, or
- h) platform does not provide safe parking for the wheelchair, or
- i) is not fitted with a constraint to prevent the wheelchair rolling off the platform, or
- j) platform cannot be manually deployed and lowered.

Wheelchair ramps (Note 2)

6. On a vehicle fitted with a wheelchair ramp that entered passenger service in New Zealand on or after 1 July 2000, or on a PSV fitted with a wheelchair ramp on or after 1 July 2000, a wheelchair ramp and its fitting to a PSV:

- a) does not, from the driving position, allow an unobstructed view of :
 - i. the exterior and interior of the doorway used for entry and exit, or
 - ii. the wheelchair parking position, or
 - iii. the ramp, unless where the ramp is power operated and cannot be seen clearly by the driver, or
- b) if it is power operated and cannot be clearly seen by the driver, does not stop or retract if it meets an obstruction before it is fully extended, or
- c) does not have on the ramp side edges:

i. a safety ridge, or

ii. a conspicuous stripe at least 20 mm wide, or

d) does not have adequate illumination of the fully extended ramp to enable safe use during the hours of darkness, or

e) if it is power operated, the ramp:

i. has no audible warning while the ramp is extending or retracting, or

ii. has no safety system to prevent the vehicle from moving off while the ramp is extended, or

iii. cannot be manually deployed and lowered in the event of a power failure.

7. A wheelchair ramp:

a) if side-mounted, has no device that warns the driver when the ramp is not stowed, or

b) has a moving part which touches the vehicle during the raising/lowering cycle.

Modification

8. An entry and exit step or ramp, or a wheelchair hoist or ramp, was modified since the last CoF inspection and there is no written confirmation that items affected by the modification comply with the requirements for [entry certification](#).

Note 1

Wheelchair hoist means an appliance attached to the vehicle which is used for raising or lowering wheelchairs and their occupants into or out of the vehicle.

Note 2

Wheelchair ramp means an inclined platform that is either permanently or temporarily attached to the vehicle to allow wheelchairs and their occupants into or out of the vehicle.

Summary of legislation

Applicable legislation

- [Land Transport Rule: Passenger Service Vehicles 1999](#)
- AS 3856.1–1991
- AS 3856.2–1991
- AS/NZS 3856.1–1998
- AS/NZS 3856.2–1998.

Mandatory requirement

1. On a vehicle fitted with a wheelchair ramp that entered passenger service in New Zealand on or after 1 July 2000, or on a PSV fitted with a wheelchair ramp on or after 1 July 2000, a wheelchair ramp and its fitting to a PSV must be certified by an LVV specialist certifier.

2. On a vehicle fitted with a wheelchair hoist that entered passenger service in New Zealand on or after 1 July 2000, or on a PSV fitted with a wheelchair hoist on or after 1 July 2000, a wheelchair hoist and its attachment to a PSV must be certified by an LVV specialist certifier.

3. On a vehicle fitted with a wheelchair hoist that entered passenger service in New Zealand on or after 1 July 2000, or on a PSV fitted with a wheelchair hoist on or after 1 July 2000, a wheelchair ramp or hoist must display a load rating of at least 300kg.

Condition and performance

4. The step-tread surfaces of entry and exit steps and ramps must be of a slip-resistant material.
5. Entry and exit steps and ramps must provide safe entry or exit for the occupants of a PSV.
6. External steps and ramps must be constructed so that they are not likely to injure any person.

Wheelchair hoists (Note 1)

7. The vehicle must be safe to be operated.
8. The components and materials must be fit for their purpose and within safe tolerance of their state when manufactured or modified.

Wheelchair ramps (Note 2)

9. On a vehicle fitted with a wheelchair ramp that entered passenger service in New Zealand on or after 1 July 2000, or on a PSV fitted with a wheelchair ramp on or after 1 July 2000:

- a) there must be an unobstructed view from the driving position, either directly or indirectly of:
 - i. the exterior and interior of the doorway used for entry and exit, and
 - ii. the wheelchair parking position, and
 - iii. the ramp, except where the ramp is power operated and cannot be seen clearly by the driver, it must be fitted with a sensor so that the ramp stops or retracts if it meets an obstruction before it is fully extended, and
- b) ramps must have a slip-resistant surface, and
- c) ramps must have:
 - i. a safety ridge along the side edges, or
 - ii. a conspicuous stripe, at least 20mm wide, along the side edges, and
- d) there must be adequate illumination of the fully extended ramp to enable safe use during the hours of darkness, and
- e) power-operated ramps must:
 - i. be fitted with a device that gives audible warning while the ramp is extending or retracting, and
 - ii. have a safety system to prevent the vehicle from moving off while the ramp is extended, and
 - iii. be able to be operated in the event of power failure.

Modification

10. An entry and exit step or ramp, or a wheelchair hoist or ramp, fitted to or modified on a light PSV since it was last certified for operation in-service, must meet the requirements for [entry certification](#).

Page amended **1 November 2017** (see [amendment details](#))

Page updated **9 May 2018** (see [details](#))

6-4 PSV emergency exits

Reasons for rejection

Mandatory equipment

Emergency exits (Note 3)

1. The compartment (Note 2) of a heavy PSV does not have at least (Note 6):
 - a) two emergency exits, if the compartment accommodates 26 or fewer persons, or
 - b) three emergency exits, if the compartment accommodates 27 or more persons, or
 - c) four emergency exits, if the compartment accommodates 36 or more persons and the vehicle entered service as a PSV in New Zealand on or after 1 September 1999.

Signs and markings (Note 1)

2. A dedicated emergency exit does not have at least one of the following:
 - a) a coloured band on the inside frame, at least 20mm wide, which contrasts with the background
 - b) signs on the exit, both inside and outside the PSV, with the words EMERGENCY EXIT in letters that are at least 75mm high.
3. A clear instruction sign for opening the exit:
 - a) is not displayed on or next to every dedicated emergency exit and power-operated passenger entry and exit door, both inside and outside the PSV, or
 - b) does not include the word "Emergency" in letters that are at least 10mm high, or
 - c) does not have words or drawings that identify the exit, and that clearly identify and describe or illustrate its operating mechanism.

Dedicated emergency exits (Note 4)

4. A breakable-glass dedicated emergency exit does not have a device (eg a hammer) that is capable of breaking the glass fitted in a prominent position on or next to the glass, inside the PSV.
5. The glazing of a breakable-glass dedicated emergency exit:
 - a) is laminated, or
 - b) is not made of readily breakable, toughened safety glass (refer to [section 5-1](#) of this manual for markings), or
 - c) has been modified, covered or treated in a way which might adversely affect the breakability or the removal of the glass, eg it has a vinyl overlay (Note 7).
6. A chain or similar device used to retain a dedicated emergency exit is not easily breakable or detachable.
7. A seat which is designed to tilt out of the way to provide access to a dedicated emergency exit does not have:
 - a) a single-action tilting mechanism, or
 - b) a tilting mechanism that has an automatic locking device which locks the seat in the tilted position, or

c) operating instructions.

Performance

Dedicated emergency exits (Note 4)

8. The removal of a readily removeable glass-breaking device (eg a hammer) does not generate an audible or visible warning to the driver that the hammer has been removed or tampered with.
9. A dedicated emergency exit, including its control mechanisms or associated equipment:
 - a) is likely to injure or trap any person, if it is operated according to the operating instructions, or
 - b) does not open easily from both inside and outside the vehicle when stationary, or
 - c) has sharp edges on the frame, or
 - d) has security locks or similar devices that do not give audible and visible warning to the driver when the exit is locked and the engine is running.
10. Internal access to a dedicated emergency exit is obstructed.
11. A hinged or hatch-type dedicated emergency exit does not open easily from both inside and outside the PSV (Note 5).
12. The opening of a hinged or hatch-type dedicated emergency exit does not generate an audible warning to the driver that the opening mechanism is activated, with the exception of:
 - a) an emergency hatch in the floor of the upper deck of a double-decked vehicle
 - b) an emergency roof hatch, if its internal opening device is sealed in such a way that it is clearly apparent if the seal has been opened
 - c) an emergency window, if its internal opening device is sealed in such a way that it is clearly apparent if the seal has been opened.

Modification

13. An emergency exit was modified (including fitting or removal) since the last CoF inspection and there is no written confirmation that items affected by the modification comply with the requirements for [entry certification](#).

Note 1

These requirements are for heavy PSV emergency exit signs. Section 7-10 covers signs and instructions generally.

Note 2

Compartment, for the purposes of emergency exits, means:

- a) the separated driver's compartment
- b) the upper and lower passenger compartments of a double-decked vehicle
- c) the front and rear sections of the passenger compartment of an articulated bus
- d) the passenger compartment of a single-decked non-articulated bus.

Note 3

Emergency exit means:

- a) a door used for the entry and exit of the occupants and, for this purpose, a door of double width is a single emergency exit
- b) the access between the front and rear sections of an articulated bus
- c) the stairway from the upper deck to the lower deck
- d) a dedicated emergency exit.

Note 4

Dedicated emergency exit means any doorway, window, hatch or other opening that is designed and constructed solely to provide a means of leaving the vehicle in the event of an emergency.

Note 6

A sliding or similar type of dedicated emergency exit, which is likely to jam even with slight distortion of the vehicle body, must not be taken into account when counting the number of required emergency exits

Note 7

An overlay may be fitted providing it has a gap of at least 4mm between the overlay material and the window edge where it meets the rubber seal or the edge of the adhesive. The gap must be around the entire perimeter of the exit and around a burst device.

Summary of legislation

Applicable legislation

- [Land Transport Rule: Passenger Service Vehicles 1999](#).

Mandatory equipment

Emergency exits (Note 3)

1. The compartment (Note 2) of a heavy PSV must have at least:
 - a) two emergency exits, if the compartment accommodates 26 or fewer persons, or
 - b) three emergency exits, if the compartment accommodates 27 or more persons, or
 - c) four emergency exits, if the compartment accommodates 36 or more persons and the vehicle entered service as a PSV in New Zealand on or after 1 September 1999.

Signs and markings (Note 1)

2. A dedicated emergency exit must have:

- a) a coloured band on the inside frame, at least 20 mm wide, which contrasts with the background, or
- b) signs on the exit, both inside and outside the PSV, with the words EMERGENCY EXIT in letters that are at least 75mm high.

3. A clear instruction sign for opening the exit must be displayed:

- a) both inside and outside the vehicle on or next to every:
 - i. power-operated passenger entry and exit door, and
 - ii. dedicated emergency exit, and
- b) the clear instruction sign must include:
 - i. the word "Emergency" in letters that are at least 10 mm high, and
 - ii. words or drawings that identify the exit, and clearly identify and describe or illustrate its operating mechanism.

Dedicated emergency exits (Note 4)

4. A breakable-glass dedicated emergency exit must have a device that is capable of breaking the glass to enable the safe exit of passengers:

- a) is provided in a prominent position on or next to the glass, on the inside of the vehicle, and
- b) if the device is readily removeable there must be an audible or visual alarm system that alerts the driver if the device is removed or tampered with.

5. Seats which are designed to tilt out of the way to provide access to a dedicated emergency exit must have:

- a) a single-action tilting mechanism, and
- b) a tilting mechanism that has an automatic locking device which locks the seat in the tilted position, and
- c) operating instructions.

6. A chain or similar device used to retain the dedicated emergency exit must be easily breakable or detachable.

7. The glazing of a breakable-glass dedicated emergency exit must:

- a) not be laminated, and
- b) be made of readily breakable, toughened safety glass (refer to section 5-1 of this manual for markings), and
- c) not be modified, covered or treated in a way which might adversely affect the breakability or the removal of the glass.

Performance

Dedicated emergency exits (Note 4)

8. A dedicated emergency exit, its control mechanisms and associated equipment must comply with the following requirements:

- a) its operation must be unlikely to injure or trap any person, if it is operated according to the operating instructions, and
- b) it must open easily from both inside and outside the vehicle when stationary, and

c) the frame must not have sharp edges, and

d) security locks or similar devices, if fitted, must have a device which gives audible and visible warning to the driver when the exit is locked and the engine is running.

9. Internal access to a dedicated emergency exit must not be obstructed.

10. A dedicated emergency exit must open easily from both inside and outside the PSV.

11. A dedicated emergency exit must have an audible alarm system to warn the driver if the opening mechanism is activated, with the exception of:

a) a breakable-glass dedicated emergency exit

b) an emergency hatch in the floor of the upper deck of a double-decked vehicle

c) an emergency roof hatch or emergency window, if its internal opening device is sealed in such a way that it is clearly apparent if the seal has been opened.

Modification

12. If an emergency exit or dedicated emergency exit is modified (including fitting or removal) on a heavy PSV since it was last certified for operation in-service, the emergency exit or dedicated emergency exit must meet the requirements for [entry certification](#).

Page amended **1 October 2023** (see [amendment details](#)).

7 Vehicle interior

7-1 Seats and seat anchorages

Reasons for rejection

Mandatory equipment

1. The vehicle is not fitted with a driver's seat.
2. A seat is not attached to the vehicle structure by seat anchorages.

Condition and performance

3. A seat frame or seat structure has been weakened, eg due to damage, corrosion or excessive wear.
4. The adjustment mechanism of a driver's seat:
 - a) does not operate, or
 - b) is worn, causing excessive movement of the seat.
5. The attachment of the seat to the seat anchorage is loose or weakened by damage.
6. The attachment of the seat anchorage to the vehicle structure is loose or weakened by damage.
7. There is corrosion damage within 150mm of a seat anchorage (Note 4).
8. There is corrosion damage within 300mm of the anchorage of a seat with integrated seatbelt anchorages (Note 4).

9. A driver's seat is in such a condition that it does not allow the driver to have proper control of the vehicle.

Modification

10. A modification (Note 3) carried out after 1 March 1999 affects a seat or seat anchorage, and:

- a) is not excluded from the requirements for LVV specialist certification (Table 7-1-1), and
- b) is missing proof of LVV specialist or accepted overseas certification, ie:
 - i. the vehicle is not fitted with a valid LVV certification plate, or
 - ii. the operator is not able to produce a valid modification declaration or authority card , or
 - iii. the vehicle has not been certified to an accepted overseas system as described in [Technical bulletin 13](#)

Note 2

Corrosion damage is where the metal has been eaten away, which is evident by pitting. The outward sign of such corrosion damage is typically displayed by the lifting or bubbling of paint. In extreme cases, the area affected by the corrosion damage will fall out and leave a hole.

Note 3 Definitions

Modify means to change a vehicle from its original state by altering, substituting, adding or removing a structure, system, component or equipment, but does not include repair.

Repair means to restore a damaged or worn vehicle, its structure, systems, components or equipment to within safe tolerance of its condition when manufactured, including replacement with undamaged or new structures, systems, components or equipment.

Seat means an assembly, or part of an assembly, intended to seat at least one person, which may or may not be integral to the structure of the vehicle, and includes components, such as rails and runners, that attach to the seat anchorages.

Seat anchorages means the parts of the vehicle structure to which a seat is attached.

Note 4

Where the inspector is presented with a Nissan Terrano or Nissan Mistral vehicle of the type that is fitted with a two-layer (double skin) floor panel, the inspection procedure in [Technical bulletin 2](#) must be followed.

Note 5

Where a seat with an integrated airbag is fitted with a seat cover that is not airbag compatible, this modification is allowed (a pass), but the inspector should advise the operator, for example by putting a note on the checksheet , that the seat airbag may not work properly in a crash. Airbag compatible seat covers are now readily available.

Note 6

- Where a manufacturer fitted or LVV certified seat has been removed, a seatbelt is not required for that position, so any remaining seatbelt or seatbelt anchorage components are not required to be inspected.
- Where an LVV certified seat has been temporarily removed, meaning that the information on the LVV plate differs from the vehicle, this is not on its own a reason for rejection.
- Where seatbelt or seatbelt anchorage components remain fitted, and the vehicle is such that the removed seats can be readily re-fitted and used with the seatbelts, the vehicle inspector must:
 - identify which seats were missing when the vehicle was presented for inspection, and
 - advise the vehicle operator that the remaining seatbelt components have not been checked, and that if the missing seats are re-fitted at a later stage, it is the vehicle operators' responsibility to ensure that these seats and seatbelts are compliant prior to using them.

If the inspector chooses to inspect any remaining seatbelt components, then they should identify that to the vehicle operator. Any defects should be noted on the checksheet, but must not be failed. The same information as noted above must be recorded on the checksheet to make it clear that the responsibility lies with the vehicle operator if seats are re-fitted.

Table 7-1-1. Modifications that do not require LVV certification

Fitting of or modification to:	LVV certification is not required provided that:
<p>Aftermarket 'Retro' brand child seats designed for children 5–12 years old (up to 38kg)</p>	<ul style="list-style-type: none"> • the seat is identified as complying with the Australian Federal Code of Practice VSB-5A (category 2 and 3) and installed by Auckland Auto Trimmers or their agents before 1 June 2012.
<p>Seats – modification or replacement or installation of a seat anchorage after 1 March 1999</p>	<ul style="list-style-type: none"> • The seat is of stressed type (Note 7) and is an unmodified OE seat sourced from the same make and model vehicle, and <ul style="list-style-type: none"> ○ the seat is directly bolted to the original OE seat mounts and, ○ no additional components or modifications are required for the fitting of the seat, and ○ no airbag has been removed or disabled (see info sheet 07-2009 https://www.lvvta.org.nz/documents/infosheets/LVVTA_Info_07-2009_Removal_of_Side_Airbag-equipped_Seats.pdf). • the seat of unstressed type (see note 1) and is either an unmodified OE seat from another vehicle or of a known and reputable aftermarket brand, and <ul style="list-style-type: none"> ○ no airbag has been removed or disabled, and ○ the seat is fitted to unmodified OE seat anchorages, and ○ the seatbelt anchorage or operation is not affected or moved, and ○ the seat components (including brackets, runners and rails) are compatible with each other, i.e. they are either OE components from a production vehicle or of a known and reputable aftermarket brand, and are not fitted together by welding, and ○ the relationship between seat, seat occupant, front airbag and location of the seatbelt anchorages is not affected. <p>Note LVV certification is not required where the only modification is the removal of seats and/or seatbelts. However, a class change, and a new load rating may be required in some cases.</p>

Fitting of or modification to:	LVV certification is not required provided that:
Campervan conversions	<ul style="list-style-type: none"> • The conversion was completed before 1/3/1999, or • The conversion was completed on or after 1/3/1999, and <ul style="list-style-type: none"> ◦ no modifications were carried out to the vehicle rear wall, and ◦ modifications to the roof meet the following requirements: <ul style="list-style-type: none"> ▪ Only a single layer of sheet metal may be cut per roof opening, and ▪ any bracing or structural elements have not been modified, and ▪ no modifications are within 150mm of a seatbelt anchorage. and ◦ no seats or seatbelt anchorages were retrofitted, or • There is evidence of certification of the modification from the company that carried out the modification, i.e. a secondary certification plate or label in the case of a motorhome conversion (see Technical bulletin 13). <p>See also Table 3-1-1 and Table 7-5-1</p>
Fitting of or modification to:	LVV certification is never required:
Seat pads or covers (see (Note 5) for seats with integrated airbags)	<ul style="list-style-type: none"> • in-service requirements for condition and performance must be met.
Any modification for the purpose of law enforcement or the provision of emergency services	

Note 7

A stressed type seat is a seat to which a seatbelt is directly mounted to any of the components that make up the seat and seat frame. An unstressed seat has no seatbelt attachment point on either the seat or the seat frame (i.e. the seat belt is attached to a different part of the vehicle structure).

Summary of legislation

Applicable legislation

- [Land Transport Rule: Seats and Seat Anchorages 2002](#).

Mandatory equipment

1. A motor vehicle must be fitted with a driver's seat.
2. A seat in a motor vehicle must be fitted to the vehicle structure by means of seat anchorages.

Condition and performance

3. Seats and seat anchorages must be safe, strong, in sound condition and compatible in strength with each other and with the vehicle structure.

4. The driver's seat and its anchorages must be designed, constructed and maintained to enable the driver to have proper control of the vehicle.
5. Seats and seat anchorages must be securely attached to the vehicle structure.
6. When a seatbelt or any part of the seatbelt is integral to a seat, the seat and seat anchorages must be compatible in strength with the seatbelt or with that part of the seatbelt attached to the seat.

Modification

7. A modification, on or after 1 March 1999 to a seat or seat anchorage must be inspected and certified by an LVV specialist certifier, unless the vehicle:
 - a) is excluded from the requirement for LVV specialist certification (Table 7-1-1), and
 - b) has been inspected in accordance with the requirements in this manual, including those for equipment, condition and performance.

Page amended **1 April 2021** (see [amendment details](#)).

7-2 PSV seating

Reasons for rejection

Mandatory requirement

1. On a vehicle fitted with a wheelchair or wheelchair and occupant restraint that entered passenger service in New Zealand on or after 1 July 2000, or on a light PSV fitted with a wheelchair occupant restraint on or after 1 July 2000, a wheelchair or wheelchair and occupant restraint has not been certified by an LVV specialist certifier.

Mandatory and permitted equipment

2. The driver's seat is not adjustable.
3. Refer to [section 7-1](#).
4. There is a seat on the right-hand side of the driver's seat.
5. A forward-facing passenger seat (other than one fitted with a seatbelt) does not have either another seat, a partition or a guard rail positioned no more than 1m in front of the front edge of the seat.
6. A vehicle, except any outdoor-access vehicle (Note 2), that entered service as a PSV in New Zealand:
 - a) before 1 July 2000 does not have armrests fitted to the open ends of sideways-facing seats, or
 - b) on or after 1 July 2000 does not have armrests fitted to sideways-facing seats at intervals of 1.8 m or less as well as to the open ends of sideways-facing seats.
7. A folding crew seat (Note 1):
 - a) is fitted other than in the stairwell of the front doorway, or
 - b) does not fold away automatically when unoccupied, or
 - c) does not have clear signs stating that the seats:
 - i. are for use by crew members only, or

- ii. must be secured in the fold-away position when they are not being used.

Wheelchair and wheelchair-occupant restraints

8. A PSV that entered passenger service in New Zealand on or after 1 July 2000, and is designed to carry a forward-facing wheelchair and occupant, is not fitted with a restraint system for a wheelchair.
9. A light PSV that entered passenger service in New Zealand on or after 1 July 2000 and that is designed to carry a rearward-facing wheelchair and occupant is not fitted with a backrest head support and a restraint system for a wheelchair.
10. A restraint system for a wheelchair, or for a wheelchair and occupant, on a vehicle that entered passenger service in New Zealand on or after 1 July 2000, or that was fitted with such equipment on or after 1 July 2000 **is not certified by an LVV specialist certifier, or doesn't meet all of the following requirements:**
 - a) a horizontal handrail adjacent to the wheelchair parking position for wheelchair occupants to steady themselves while the passenger service vehicle is moving, or
 - b) a means of preventing the wheelchair from tipping backwards, or
 - c) a head support if the back of the wheelchair occupant's head would be against a window, bulkhead or partition, or
 - d) a means of preventing the wheelchair from swinging out of position or tipping over, or
 - e) a sign adjacent to the wheelchair parking position stating that the restraint system must be secured and the wheelchair's brakes applied, or
 - f) easily accessible quick-release mechanisms.

Condition and performance

11. Refer to [section 7-1](#).
12. A wheelchair or wheelchair-occupant restraint does not meet the condition and performance requirements of [section 7-5, general vehicle pages](#).
13. The driver does not have safe and reasonably easy access to the driver's seat.
14. The driving controls are not protected, or located in such a way as to minimise the risk that they will be operated accidentally.

Modification

15. Refer to [section 7-1](#).
16. A seat or seating arrangement, including a wheelchair or wheelchair occupant restraint system, has been modified since the last CoF inspection and there is no written confirmation that items affected by the modification comply with the requirements for [entry certification](#).

Note 1

Crew, in relation to a PSV, means the person or group of persons in control or having responsibility for the operation of the vehicle or the wellbeing of the passengers.

Note 2

Outdoor-access vehicle means a motor vehicle that is used to provide access to remote areas solely in connection with outdoor activities.

Summary of legislation

Applicable legislation

- [Land Transport Rule: Passenger Service Vehicles 1999](#).

Mandatory requirement

1. On a vehicle fitted with a wheelchair or wheelchair and occupant restraint that entered passenger service in New Zealand on or after 1 July 2000, or on a light PSV fitted with a wheelchair occupant restraint on or after 1 July 2000, a wheelchair occupant restraint must be certified by an LVV specialist certifier.

Mandatory and permitted equipment

2. A driver's seat must be adjustable to ensure the driver has access to the driving controls.
3. Refer to [section 7-1](#).
4. There must not be a seat on the right-hand side of the driver's seat.
5. Every forward-facing passenger seat must have either another seat, a partition or a guard rail positioned no more than 1 m in front of the front edge of the seat unless the seat is fitted with a seatbelt.
6. A vehicle, except any outdoor-access vehicle (Note 2), that entered service as a PSV in New Zealand:
 - a) before 1 July 2000 must have armrests fitted to the open ends of sideways-facing seats, or
 - b) on or after 1 July 2000 must have armrests fitted to sideways-facing seats at intervals of 1.8 m or less as well as to the open ends of sideways-facing seats.
7. Folding crew seats (Note 1):
 - a) may be fitted only in the stairwell of the front doorway of a PSV, and
 - b) must fold away automatically when unoccupied, and
 - c) must have clear signs stating that the seats:
 - i. are for use by crew members only, and
 - ii. must be secured in the fold-away position when they are not being used.

Wheelchair and wheelchair-occupant restraints

8. A restraint system for a wheelchair, or for a wheelchair and occupant, must:

- a) comply with the design and construction requirements of the version of AS 2942-1987 or the version of AS 2942:1994/Amdt 1-1998 that was applicable at the time it was attached; or

b) be certified in accordance with Land Transport Rule: Vehicle Standards Compliance 2002 as complying with, or being equivalent to, the technical requirements of the version of AS 2942-1987 or the version of AS 29421994/Amdt 1-1998 that was applicable at the time it was fitted, or

c) comply with all of the following requirements:

i. there must be a horizontal handrail adjacent to the wheelchair parking position for wheelchair occupants to steady themselves while the passenger service vehicle is moving; and

ii. the wheelchair must be prevented from tipping backwards; and

iii. a head support must be fitted if the back of the wheelchair occupant's head would be against a window, bulkhead or partition; and

iv. a restraint system must be fitted to prevent the wheelchair from swinging out of position or tipping over; and

v. there must be a sign adjacent to the wheelchair parking position stating that the restraint system must be secured and the wheelchair's brakes applied; and

vi. the restraint system must include easily accessible quick-release mechanisms; and

vii. a vehicle inspector must certify that the seatbelt anchorage or alternative wheelchair restraint system complies with the version of Australian Design Rule 5/03 which was applicable at the time it was installed, or can withstand equal loadings in the case of an alternative restraint system.

9. A PSV that entered passenger service in New Zealand on or after 1 July 2000 that is designed to carry a forward-facing wheelchair and occupant must be fitted with a restraint system for a wheelchair.

10. A light PSV that entered passenger service in New Zealand on or after 1 July 2000 that is designed to carry a rearward-facing wheelchair and occupant, must be fitted with a backrest head support and a restraint system for a wheelchair.

11. Refer to [section 7-1](#).

12. The driver must have safe and reasonably easy access to the driver's seat.

13. The driving controls must be protected, or located in such a way as to minimise the risk that they will be operated accidentally.

Modification

14. Refer to [section 7-1](#).

15. If a passenger seat, crew seat, wheelchair restraint system, or wheelchair and occupant restraint system is fitted, relocated or modified in a light PSV since it was last certified for operation in-service, the passenger seat, crew seat, wheelchair restraint system or wheelchair and occupant restraint system must comply with the requirements for [entry certification](#).

Page amended 1 October 2012 (see [amendment details](#)).

7-3 Head restraints

Reasons for rejection

Condition and performance

1. The external surfaces and padding of a head restraint have deteriorated to the extent that they are likely to injure a vehicle occupant.
2. An adjustable head restraint is unable to remain locked in its adjusted position.

Modification

3. A modification (Note 1) affects a head restraint, and
 - a) is not excluded from the requirements for LVV specialist certification (Table 7-3-1), and
 - b) is missing proof of LVV specialist or accepted overseas certification, ie:
 - i. the vehicle is not fitted with a valid LVV certification plate, or
 - ii. the operator is not able to produce a valid modification declaration or authority card, or
 - iii. the vehicle has not been certified to an accepted overseas system as described in [Technical bulletin 13](#).

Note 1 Definitions

Modify means to change a vehicle from its original state by altering, substituting, adding or removing a structure, system, component or equipment, but does not include repair.

Repair means to restore a damaged or worn vehicle, its structure, systems, components or equipment to within safe tolerance of its condition when manufactured, including replacement with undamaged or new structures, systems, components or equipment.

Table 7-3-1. Modifications that do not require LVV certification

Fitting of or modification to:	LVV certification is not required provided that:
Head restraint removal	<ul style="list-style-type: none"> • A front head restraint must not be removed from a vehicle if: <ul style="list-style-type: none"> ◦ there is a solid structure within 300mm behind the seat back, or ◦ the vehicle is required to comply with a frontal impact occupant protection standard (Note 2) • A rear head restraint must not be removed from a vehicle if there is a solid structure within 300mm behind the seat back.
Fitting of aftermarket LCD screens to head restraints	<ul style="list-style-type: none"> • the performance of the head restraint is not affected, ie the head restraint still provides sufficient padding for the seat occupant, and • the screen is fitted in a suitable manner, eg. it appears similar to OE fitments in other vehicles, or • the screen can be easily attached or removed.
Fitting of or modification to:	LVV certification is never required:
<ul style="list-style-type: none"> • Any modification for the purpose of law enforcement or the provision of emergency services 	<ul style="list-style-type: none"> • in-service requirements for condition and performance must be met.

Note 2

The following vehicles with a GVM of 2500 kg or less are required to comply with such a standard:

- class MA motor vehicles manufactured from 1 March 1999, and
- class MA motor vehicles that were less than 20 years old when they were first registered in New Zealand on or after 1 April 2002, and
- class MB or MC motor vehicles manufactured from 1 October 2003.

Summary of legislation

Applicable legislation

- [Land Transport Rule: Head Restraints 2001](#)
- [Land Transport Rule: Frontal Impact 2001](#).

Permitted equipment

1. A motor vehicle may be fitted with head restraints.

Condition and performance

2. The external surfaces and padding of a head restraint must not have deteriorated to the extent that the likelihood of injury to an occupant of the vehicle is increased.
3. An adjustable head restraint must remain able to be adjusted and locked into position.

Modification

4. A modification that affects a head restraint must be inspected and certified by an LVV specialist certifier, unless the vehicle is:
 - a) excluded from the requirement for LVV specialist certification (Table 7-3-1), and
 - b) has been inspected in accordance with the requirements in this manual, including those for equipment, condition and performance.

Page amended **29 April 2020** (see [amendment details](#)).

7-4 PSV aisles

Note An unmodified vehicle is not required to comply with section 7-4 provided that it complies with either:

- **UN/ECE 36 and UN/ECE 66; UN/ECE 107 and UN/ECE 66; UN/ECE 52 or Directive 2001/85/EC.**

Reasons for rejection

Mandatory equipment

1. A PSV does not have at least one of the following:
 - a) an aisle to provide unobstructed access throughout the PSV from each doorway used for passenger entry and exit
 - b) a door alongside every seat or every row of forward-facing or rearward-facing seats
 - c) a doorway that gives access to a compartment with fewer than nine seating positions in two rows of seats that face each other and opens into the space between the seats
 - d) in an outdoor-access vehicle with sideways-facing seats, at least a 300mm space between the front edges of seats which face each other, and at least 300mm foot room for any other seats.

Aisle steps and ramps

2. A flight of aisle steps, an internal ramp or a landing is not provided with handrails, handholds, or handgrips.

Aisles in a PSV used for standing passengers

3. A PSV with a certificate of loading that allows standing passengers is not fitted with handrails, handholds or handgrips whose number and location are appropriate for:
 - a) the number of passengers permitted to occupy the aisle, or
 - b) passengers of different heights.

Condition and performance

4. A light, push button, air vent or similar device:
 - a) projects more than 5mm into the required minimum aisle space, or
 - b) is not designed to minimise the risk of injury to passengers.
5. A handrail, handhold or handgrip is:
 - a) not suitable, or
 - b) not securely attached, or
 - c) in a condition such that it is likely to injure a person.
6. The aisle step-tread surfaces are:
 - a) not of a **slip-resistant** material, or
 - b) slippery or have deteriorated so that they are no longer safe to use.

Modification

7. An aisle arrangement was modified since the last CoF inspection and there is no written confirmation that items affected by the modification comply with the requirements for [entry certification](#).

Summary of legislation

Applicable legislation

- [Land Transport Rule: Passenger Service Vehicles 1999](#)

Mandatory equipment

1. An aisle is required in a PSV to provide unobstructed access throughout the PSV from each doorway used for passenger entry and exit, except where:
 - a) there is a door alongside every seat or every row of forward- or rearward-facing seats, or
 - b) a doorway:
 - i. gives access to a compartment with fewer than nine seating positions in two rows of seats which face each other, and
 - ii. opens into the space between the seats, or
 - c) the sideways-facing seats in an outdoor-access vehicle have at least a 300mm space between the front edges of seats which face each other, and there is at least 300mm foot room for any other seats.

Aisle steps and ramps

2. Aisle steps, internal ramps and landings must be provided with suitable handrails, handholds or handgrips.

Aisles in a PSV used for standing passengers

3. If the certificate of loading allows standing passengers to be carried on the PSV, handrails, handholds or handgrips must be fitted, whose number and location must be appropriate for the number of passengers permitted to occupy the

aisle and for passengers of different heights.

Performance

4. An aisle, where required, must provide unobstructed access throughout the PSV from each doorway used for passenger entry and exit.
5. The aisle, where required, must be clear of any fixture, except that lights, push buttons, air vents, and similar devices may project up to 5mm into the required minimum aisle-height space, provided it is designed to minimise the risk of injury to passengers.

Aisle steps and ramps

6. The aisle step-tread surfaces must be of a **slip-resistant** material.

Modification

7. If an aisle in a PSV has been modified since it was last certified for operation in-service, the aisle must meet the requirements for [entry certification](#).

Page amended 1 October 2012 (see [amendment details](#)).

7-5 Seatbelts and seatbelt anchorages

Reasons for rejection

Mandatory equipment

- see Note 20, Note 21
1. A seatbelt (Note 1) of the type specified in Table 7-5-1 (first registered in NZ before 1/1/1991), Table 7-5-2 (first registered in NZ between 1/1/1991 and 31/3/2002) and Table 7-5-3 (first registered in NZ from 1/4/2002) has not been fitted for the relevant seating position (see (Note 18) for permitted specialist seatbelts), and
 - a) the requirements for specific motor vehicles in Table 7-5-4 are not met, or
 - b) the requirements for modification in Table 7-5-5 are not met.
 2. A seat that can be rotated or reversed to face in different directions, for which seatbelts are not provided for all directions, has no notice easily visible by the seat occupant that indicates the direction the seat must (or must not) face when the vehicle is moving.
 3. A three-point seatbelt imported and distributed by BVL (Business Ventures Limited) and manufactured by Changzhou BWD, China or Jiang Su Jiu Jiu Traffic Facilities Co. Ltd. is installed (see Figure 7-5-6 for samples to help identify the seatbelts).
 - See also the [Safety alert: Seatbelts imported by BVL \(Business Ventures Limited\)](#)
 4. A re-webbed seatbelt is fitted without evidence of exemption from requirements by NZTA.
 - See [Technical bulletin: Seatbelt repair and re-webbing](#)

Condition

- see Note 20

Seatbelts

- see Figure 7-5-7 for guidance on webbing damage and Figure 7-5-8 for guidance on passable webbing indentations.

5. The seatbelt assembly is not securely fixed to a seatbelt anchorage.

6. A seatbelt component (eg protective plastic cover on buckle, tongue or retractor system) is damaged so that foreign objects may enter the interior components, or that they may cause damage to the interior components, mechanisms or webbing.

7. The seatbelt webbing (including webbing attached to the buckle) has:

a) a cut, including a cut on the surface, or

b) a rip or tear, or

c) fraying, or

d) stretching (eg the belt has unusual web patterns or the webbing is deformed, will not lie flat, or is curled or rippled) (see Figure 7-5-8 for exceptions), or

e) fading so that most of the colour has been bleached, and:

i. shows signs of chalking, or a powdery residue is evident on the webbing, or

ii. it has become stiff

f) been dyed to conceal fading, or

g) contamination from grease, paint, solvents or similar products.

h) been replaced or shows other signs of repair (Note 14) and there is no evidence of approval from the seatbelt manufacturer.

Note Such approval is very unlikely.

8. The seatbelt stitching:

a) is damaged or insecure, or

b) shows signs of home repair, eg gluing, stitching by hand or home sewing machine, staples, bolts, or rivets, or

c) indicates that the 'rip stitch' system has been activated, ie the stitching is broken and a 'REPLACE BELT' label has been exposed near the lower seatbelt anchorage, or this label has been cut off.

9. A buckle and tongue:

a) are mismatched, or

b) do not lock, or

c) do not remain locked, or

d) do not release easily, or

e) are insecure when coupled.

10. A component is missing (Note 19), or is cracked, distorted, damaged or deteriorated in such a way that:

- a) its strength or integrity is reduced, or
- b) it may damage another component or the webbing, or
- c) foreign matter may enter the interior of the mechanism, or
- d) the seatbelt or a seatbelt component cannot function as intended (does not apply to securely locked seatbelt height adjusters).

11. A seatbelt stalk:

- a) (wire-cable type) shows broken wires, or
- b) (plastic-covered webbing type) webbing has deteriorated, or is frayed, cut or faded, or
- c) (solid metal type) is corroded, cracked or buckled, or
- d) is not the correct type for the vehicle or the seating position.

12. A seatbelt pretensioning system has not been replaced after activation.

Seatbelt anchorages

13. A seatbelt anchorage (Note 12):

- a) is not securely fixed to the vehicle structure, or
- b) is not securely fixed to the seat if the seatbelt is an integral part of the seat, or
- c) is corroded, damaged or shows signs of tampering, or
- d) has evidence of corrosion damage (Note 13) (Note 17) or structural damage within 150mm of a lower seatbelt anchorage mounted in a wheel arch, or within 300mm of any other seatbelt anchorage.

Performance

- see Note 19

14. The seatbelt webbing of a retractor-type seatbelt does not easily pull out from the retractor.

15. The seatbelt webbing of a retractor-type seatbelt has difficulty retracting, eg is slow or intermittent, or does not fully retract.

16. A static seatbelt cannot be adjusted to fit a variety of persons.

17. The seatbelt is not of sufficient length to fit a variety of persons.

18. A seatbelt is located so that it cannot be readily fastened or released by the wearer.

19. The web and/or vehicle sensitivity of a dual-sensitive retractor type seatbelt fitted in a front seating position does not function correctly.

20. The vehicle sensitivity of a single-sensitive retractor type seatbelt fitted in a front seating position does not function correctly.

21. The web sensitivity of a dual-sensitive retractor type seatbelt fitted in a rear seating position does not function correctly.

22. The vehicle sensitivity of a single-sensitive retractor type seatbelt fitted in a rear seating position does not function correctly.

Modification

23. A modification affects a seatbelt or seatbelt anchorage – including fitting of an alternative type of seatbelt, or a modification (since 1 January 1992) that affects a seatbelt anchorage, and

a) is not excluded from the requirements for LVV specialist certification (Table 7-5-5), and

b) is missing proof of LVV specialist or accepted overseas certification, ie:

i. the vehicle is not fitted with a valid LVV certification plate, or

ii. the operator is not able to produce a valid modification declaration or authority card, or

iii. the vehicle has not been certified to an accepted overseas system as described in [Technical bulletin 13](#) .

24. The seatbelt assembly has been removed after it was rejected for one or more reasons for rejection due to **Condition** or **Performance** (above), whether or not the seatbelt is required to be fitted.

Note 1

Seatbelt means an assembly of straps made of webbing or metal with a securing buckle, adjusting devices and attachments, including any device for absorbing energy or for retracting the webbing, that is:

a) able to be anchored to the interior of a vehicle, and

b) designed to diminish the risk of injury to its wearer in the event of a collision or abrupt deceleration of the vehicle by

limiting the mobility of the wearer's body.

Note 2

Retractor means a device to accommodate parts, or all, of the webbing of a seatbelt.

Note 3

Single-sensitive means a seatbelt retractor that, during normal driving conditions, allows freedom of movement by the wearer of the seatbelt by means of length-adjusting components that automatically adjust the seatbelt to the wearer, and that comprises a locking mechanism activated in an emergency by deceleration of the vehicle (ie the seatbelt is vehicle sensitive).

Note 4

Dual-sensitive means a seatbelt retractor that, during normal driving conditions, allows freedom of movement by the wearer of the seatbelt by means of length-adjusting components that automatically adjust the strap to the wearer, and that is activated by two or more of the following:

a) deceleration of the vehicle, or

b) acceleration of the strap from the retractor, or

c) other means of activation.

Note 5

Seating position means a seat or part of a seat that is of a suitable size and shape for one person.

Note 6

Outer seating position means a seating position next to a side wall of a vehicle where there is no more than 500mm between the longitudinal centre of the seat and the side wall.

Note 7

Middle seating position means a seating position in a vehicle that is not an outer seating position.

Note 9

Monocoque, in relation to a motor vehicle, means that the chassis of the vehicle is integral to the body.

Note 10

Retrofit, in relation to a seatbelt or seatbelt anchorage in a motor vehicle, means to fit a seatbelt or seatbelt anchorage in a location where a seatbelt or seatbelt anchorage has not been fitted before.

Note 11

Motorhome means a motor vehicle, other than a trailer, that is permanently equipped with features intended to make the vehicle suitable as a dwelling place, and must include at least one sleeping berth and one table, both of which may be of a design that allows them to be retracted or folded away.

- For the purposes of this section, motorhomes and campervans are interchangeable terms.

Note 12

Seatbelt anchorage means the parts of a vehicle structure, seat structure or any other part of the vehicle to which a seatbelt assembly is attached.

Note 13

Corrosion damage is where the metal has been eaten away, which is evident by pitting. The outward signs of such corrosion damage is typically displayed by the lifting or bubbling of paint. In extreme cases the area affected by the corrosion damage will fall out and leave a hole.

Note 14

Modify means to change a vehicle from its original state by altering, substituting, adding or removing a structure, system, component or equipment, but does not include repair.

Repair means to restore a damaged or worn vehicle, its structure, systems, components or equipment to within safe tolerance of its condition when manufactured, including replacement with undamaged or new structures, systems, components or equipment.

- Any repairs, such as webbing or retractor replacement, must be approved by the seatbelt manufacturer. Any modification, such as fitting a different type of seatbelt or a seatbelt extension, must be approved by the seatbelt or vehicle manufacturer. It is very unlikely that a repair or modification will be approved by the vehicle or seatbelt manufacturer. Where such approval is claimed, the inspector must request appropriate evidence.

Note 15

Specialist seatbelt means a seatbelt that is designed for specialist purposes, and includes a full harness seatbelt used for motorsport activities.

Note 16

Permanent structure means a non-removable structure capable of sustaining loads associated with seatbelts and seatbelt anchorages.

Note 17

Where the inspector is presented with a Nissan Terrano or Nissan Mistral vehicle of the type that is fitted with a two-layer (double skin) floor panel, the inspection procedure in [Technical bulletin 2](#) must be followed.

Note 18

A vehicle may be fitted with seatbelts other than of type L, S, R1 or R2 only if the seatbelts are of a specialist type (eg full harness seatbelts), and:

- a) the specialist seatbelts are the vehicle manufacturer's original equipment specification, or
- b) the specialist seatbelts have been fitted for a specific purpose (eg motorsport), and the operator produces a valid LVV authority card, or
- c) the vehicle is scratchbuilt and the specialist seatbelts are noted on the LVV plate.

Note 19

Some class MA vehicles must have a type R2 webbing clamp seatbelt in a front outer seating position when a type R1 or R2 seatbelt in that position failed an in-service inspection because of its condition or performance. Refer to [Technical bulletin 5](#) for requirements and exceptions.

Note 20

Where a seat has been removed, a seatbelt is not required for that position, and any remaining seatbelt or seatbelt anchorage components are not required to be inspected. Where seatbelt or seatbelt anchorage components remain fitted, and the vehicle is such that the removed seats can be readily re-fitted and used with the seatbelts, the vehicle inspector must:

- Identify which seats were missing when the vehicle was presented for inspection, and

- Advise the vehicle operator that the remaining seatbelt components have not been checked, and that if the missing seats are re-fitted at a later stage, it is the vehicle operators' responsibility to ensure that these seats and seatbelts are compliant prior to using them.

If the inspector chooses to inspect any remaining seatbelt components, then they should identify that to the vehicle operator. Any defects should be noted on the checksheet, but must not be failed. The same information as noted above must be recorded on the checksheet to make it clear that the responsibility lies with the vehicle operator if seats are re-fitted.

Note 21

Except as provided by Table 7-5-5, any seatbelt fitted to a seating position of a vehicle—either having been entry certified (as originally manufactured or modified) or subsequently specialist certified—must remain and be restored when damaged. It cannot be removed on the grounds that Table 7-5-1, Table 7-5-2, or Table 7-5-3 doesn't require the seatbelt.

Key to Table 7-5-1, Table 7-5-2 and Table 7-5-3: Types of seatbelts¹

–	No seatbelt required
L	Lap seatbelt
S	Static lap-and-diagonal seatbelt without a retractor (Note 2)
R1	Single-sensitive emergency-locking retractor (ELR) lap and diagonal seatbelt (Note 3)
R2	Multiple- (dual-) sensitive emergency-locking retractor lap-and-diagonal seatbelt (Note 4)

¹ A requirement for a specified type of seatbelt may be met by the type specified or another type below it in the key.

Table 7-5-1. Vehicles first registered in New Zealand before 1 January 1991

Vehicle class	Seating position (Note 5)	First registered anywhere	
		1/1/1955–31/10/1979	1/11/1979–31/12/1990
MA, MB, MC LE (without motorcycle controls) (tare <2000 kg)	Front outer and driver's (Note 6)	S ²	R2 ^{1, 3}
	Front middle (Note 7)	–	L
	Rear outer (Note 8)	–	R2 or R1 or S
	Rear middle	–	L
NA (tare <2000 kg)	Front outer and driver's	S ²	R2 ¹
	Front middle	–	L

¹ A four-wheel-drive vehicle may be fitted with type S or type R1 seatbelts in the front outer seating position.

² May retain OE seatbelts, but replacement seatbelts must be of type S, R1 or R2.

³ A class MA vehicle must have a type R2 webbing clamp seatbelt in a front outer seating position, when a type R1 or R2 seatbelt in that position failed an in-service inspection because of its condition or performance.

Refer to [Technical bulletin 5](#) for requirements and exceptions.

Key to Table 7-5-1, Table 7-5-2 and Table 7-5-3: Types of seatbelts¹

–	No seatbelt required
L	Lap seatbelt
S	Static lap-and-diagonal seatbelt without a retractor (Note 2)
R1	Single-sensitive emergency-locking retractor (ELR) lap and diagonal seatbelt (Note 3)
R2	Multiple- (dual-) sensitive emergency-locking retractor lap-and-diagonal seatbelt (Note 4)

¹ A requirement for a specified type of seatbelt may be met by the type specified or another type below it in the key.

Table 7-5-2. Vehicles first registered in New Zealand 1 January 1991 to 31 March 2002

Vehicle class	Seating position	First registered anywhere	
		1/1/1955– 31/10/1979	1/11/1979– 31/3/2002
MA, MB, MC	Front outer and driver's	S ^{1, 2}	R2 ^{5, 6}
LE (without motorcycle controls)	Front middle	–	L
	Rear outer	–	R2 or R1 or S ¹
	Rear middle	–	L or S or R1 or R2
NA	Front outer and driver's	S ^{1, 2}	R2 ⁵
	Front middle	–	L
MD1, MD2	Front outer and driver's	–	R2 ^{3, 4, 5}
	Front middle	–	L ⁴

¹ Tare weight less than 2000 kg.

² May retain OE belts, but replacement belts must be of type S, R1 or R2.

³ Applies to MD2 only if of monocoque construction (Note 9).

⁴ If seatbelts are not fitted, but anchorages are fitted, must have seatbelts fitted from 1 October 2002. If anchorages are not fitted, seatbelts must be retrofitted from 1 October 2003.

⁵ Front type R1 seatbelts may remain fitted if they were fitted as OE and have a declaration issued by an entry certifier, or a plate affixed to the vehicle in a position approved by the Transport Agency (see Figure 7-5-2, Figure 7-5-3, Figure 7-5-4, Figure 7-5-5 and Figure 7-5-6). If missing, refer the vehicle to an entry certifier.

⁶ A class MA vehicle must have a type R2 webbing clamp seatbelt in a front outer seating position, when a type R1 or R2 seatbelt in that position failed an in-service inspection because of its condition or performance. Refer to [Technical bulletin 5](#) for requirements and exceptions.

Key to Table 7-5-1, Table 7-5-2 and Table 7-5-3: Types of seatbelts¹

–	No seatbelt required
L	Lap seatbelt
S	Static lap-and-diagonal seatbelt without a retractor (Note 2)
R1	Single-sensitive emergency-locking retractor (ELR) lap and diagonal seatbelt (Note 3)
R2	Multiple- (dual-) sensitive emergency-locking retractor lap-and-diagonal seatbelt (Note 4)

¹ A requirement for a specified type of seatbelt may be met by the type specified or another type below it in the key.

Table 7-5-3. Vehicles first registered in New Zealand from 1 April 2002

Vehicle class	Seating position	Manufactured		
		1/1/1955–31/10/1979	1/11/1979–30/9/2003	1/10/2003–
MA, MB, MC LE (without motorcycle controls)	Front outer and driver's	S ^{1, 2}	R2 ^{5, 6}	R2 ^{5, 6}
	Front middle	–	L	L
	Rear outer	–	R2 or R1 or S ¹	L ⁸ or R2 or R1
	Rear middle	–	L or S or R1 or R2	L or S or R1 or R2
NA (excluding motorhomes manufactured from 1 October 2003, refer to Table 7-5-4)	Front outer and driver's	S ^{1, 2}	R2 ⁵	R2 ⁵
	Front middle	–	L	L
	Rear outer	–	–	R2 or R1
	Rear middle	–	–	L or S or R1 or R2
MD1, MD2 ⁷	Front outer and driver's	–	R2 ^{3, 4, 5}	R2 ⁵
	Front middle	–	L ^{3, 4}	L
	Rear outer	–	–	L ⁸ or R2 or R1
	Rear middle	–	–	L or S or R1 or R2

¹ Tare weight less than 2000 kg.

² May retain OE belts, but replacement belts must be of type S, R1 or R2.

³ Applies to MD2 only if of monocoque construction (Note 9).

⁴ If seatbelts are not fitted, but anchorages are fitted, must have seatbelts fitted from 1 October 2002. If anchorages are not fitted, seatbelts must be retrofitted from 1 October 2003 (Note 10).

⁵ Front type R1 seatbelts may remain fitted if they were fitted as OE and have a declaration issued by an entry certifier, or a plate affixed to the vehicle in a position approved by the Transport Agency (see Figures 7-5-2 to 7-5-6). If missing, refer the vehicle to an entry certifier.

⁶ A class MA vehicle must have a type R2 webbing clamp seatbelt in a front outer seating position, when a type R1 or R2 seatbelt in that position failed an in-service inspection because of its condition or performance. Refer to [Technical bulletin 5](#) for requirements and exceptions.

⁷ MD2 vehicles must be issued with a CoF, please refer the vehicle to the nearest CoF testing station.

⁸ For motorhomes only.

Table 7-5-4. Requirements for specific motor vehicles

Specific vehicles	Mandatory equipment
--------------------------	----------------------------

Sideways-facing seating positions

1. A Land Rover manufactured before 1 January 1991 does not require a seatbelt to be fitted.
2. A vehicle first registered in New Zealand before 1 October 2002 must have a seatbelt of any type fitted.

7-6 Frontal impact airbags

Reasons for rejection

Mandatory equipment

1. A deployed frontal impact airbag has not been replaced.
2. An OE airbag warning light system has been removed from a vehicle fitted with airbags.
3. A motor vehicle has a sign, light or other device that indicates the vehicle is fitted with an airbag when it is not fitted with an airbag.

Condition and performance

4. An airbag cover:
 - a) is damaged, or
 - b) has deteriorated (does not include deterioration of the dash surface due to the effects of sunlight), or
 - c) shows signs of tampering or inadequate repair.
5. Additional equipment has been fitted that may affect the proper performance of the airbag.
6. The airbag warning light:
 - a) does not operate, or
 - b) indicates a fault in the system.

Modification

7. A modification (Note 2) affects an airbag system (eg an airbag has been removed, or made inoperable, including retrofitting a switch), and:
 - a) is not excluded from the requirements for LVV specialist certification (Table 7-6-1), and
 - b) is missing proof of LVV specialist or accepted overseas certification, ie:
 - i. the vehicle is not fitted with a valid LVV certification plate, or
 - ii. the operator is not able to produce a valid modification declaration or authority card, or
 - iii. the vehicle has not been certified to an accepted overseas system as described in [Technical bulletin 13](#).
8. A motor vehicle that has had an airbag system removed or made inoperable and been certified as above does not:
 - a) have all OE signs, lights, or other devices that indicated the vehicle was fitted with an airbag removed, or
 - b) if the signs, lights, or other devices cannot be readily removed, have a label that indicates an airbag has been removed permanently attached in a prominent location where it is clearly visible to any occupant of the seating position that was previously protected by the airbag.