

Correct as at 24th June 2026. It may be superseded at any time.

Extract taken from: In-service certification (WoF and CoF) > Heavy vehicles > Lighting > Side-marker lamps

## 4-8 Side-marker lamps

### Reasons for rejection

#### Permitted equipment

1. A side-marker lamp is not positioned so that it gives an indication of the vehicle's dimensions.

#### Condition

2. A lamp is insecure.
3. A lens is missing, or has a hole, crack or other damage that allows moisture or dirt to enter.
4. A reflector is damaged or has deteriorated so that light output is reduced.

#### Performance

5. When switched on, a side-marker lamp emits a light that:
  - a) is not substantially white or amber to the front (for a vehicle manufactured before January 2006), or
  - b) is not substantially amber to the front (for a vehicle manufactured on or after January 2006), or
  - c) is not substantially red or amber to the rear, or
  - d) is not diffuse, or
  - e) is not approximately of the same colour and intensity on each side of the vehicle, or
  - f) does not remain steadily illuminated, or
  - g) is not bright enough to produce light that is visible from 100m in normal daylight and from 200m in normal darkness, eg due to modification, deterioration, dirt or an incorrect light source.
6. Where a lamp comprises an array of light sources (eg LEDs), fewer than 75% of these operate.

#### Modifications

7. A side-marker lamp that is affected by a modification must meet equipment, condition and performance requirements.

#### Note 1 Definitions

**Side-marker lamp** means a position lamp designed to be fitted to the side of a vehicle or its load.

**Position lamp** means a low-intensity lamp that is designed to indicate to road users the presence and dimensions of a vehicle, being:

- a) a forward-facing position lamp (front side lamp), or

- b) a rearward-facing position lamp (rear side lamp or tail lamp), or
- c) a side-marker lamp, or
- d) an end-outline marker lamp (including cab roof lamp).

**Note 2**

A permitted side-marker lamp that does not comply with equipment, condition and performance requirements must be made to comply or be disabled so that it does not emit a light.

**Figure 4-8-1. Visibility angles for side marker lamps**

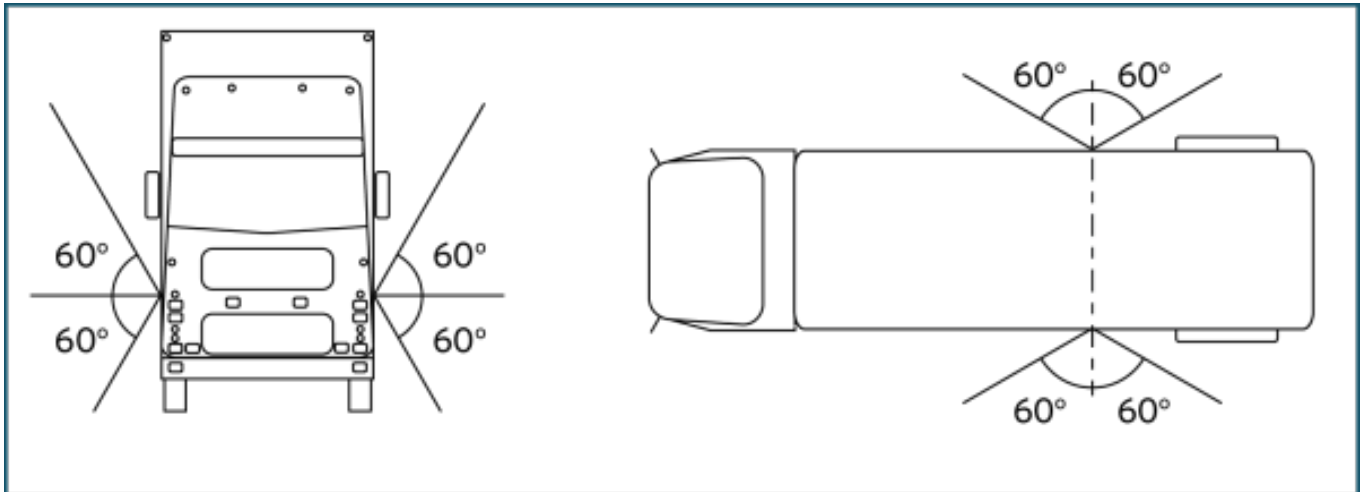

## Summary of legislation

### Permitted equipment

1. A heavy vehicle may be fitted with one or more side-marker lamps.
2. A side-marker lamp must be positioned so that it gives an indication of the vehicle's dimensions.

### Condition

3. A side-marker lamp must:
  - a) be in sound condition, and
  - b) not be obscured (if a mandatory lamp).

### Performance

4. A side-marker lamp must operate in a way that is appropriate for the lamp and the vehicle.
5. A lamp must emit a light that is:
  - a) diffuse, and
  - b) substantially white or amber to the front (for a vehicle manufactured before January 2006), or
  - c) substantially amber to the front (for a vehicle manufactured on or after January 2006), or

d) substantially red or amber to the rear.

6. A lamp must emit a steady light.

7. A side-marker lamp must provide sufficient light output to indicate to other road users the presence and dimensions of the vehicle.

8. A side-marker lamp must emit a light that is visible from a distance of 100m in daylight and 200m during the hours of darkness.

9. Where a lamp comprises an array of light sources (eg LEDs), at least 75% of these must operate.

### **Modifications**

10. A side-marker lamp that is affected by a modification must meet equipment, condition and performance requirements.

Page amended **14 October 2013** (see [amendment details](#)).