

Correct as at 27th April 2026. It may be superseded at any time.

Extract taken from: In-service certification (WoF and CoF) > Heavy PSVs > Tyres, wheels and hubs > Mudguards

## 10-3 Mudguards

### Reasons for rejection

#### Mandatory equipment

1. A mudguard over a road wheel is missing where it is reasonable and practicable to fit a mudguard, unless the vehicle is:

- a) in an unfinished condition legally used under the authority of trade plates, or
- b) not capable of exceeding a speed of 30km/h, or
- c) has a valid mudguard exemption issued by the New Zealand Hot Rod Association (Figure 10-3-4).

2. A mudguard does not cover the full tread width (Note 2) of a tyre or tyres fitted to a road wheel (Figure 10-3-1 and Figure 10-3-2), except when the mudguard is fitted to a vehicle designed for industrial purposes and it is not practicable to fit a full mudguard due to the vehicle's construction.

3. On a vehicle with twin or close-spaced multiple tyres a mudguard fitted over a wheel on the rear axle is more than one-third higher than the horizontal distance between the vertical lines of the lowest point of the mudguard and the centre of the wheel (Figure 10-3-3), except when:

- a) the mudguard is fitted to a vehicle designed for industrial purposes and it is not practicable to fit a full mudguard due to the vehicle's construction.

4. A truck used for transporting round timber does not have mudguards over steer axles (Figure 10-3-6).

5. A truck used for transporting round timber does not have at least partial guards fitted to the front and rear tyres of the drive axle set (Figure 10-3-6).

#### Mudguard condition

6. A mudguard is not securely fixed to the vehicle.

7. A mudguard is so constructed or damaged that it is likely to present a hazard to road users (Note 2).

#### Modification (see also [Introduction 3.1.2: Note 3](#))

8. A modification affects a mudguard, and:

- a) is not excluded from the requirements for LVV specialist certification (Table 10-3-1), and
- b) is missing proof of LVV specialist or accepted overseas certification, ie:
  - i. the vehicle is not fitted with a valid LVV certification plate, or
  - ii. the operator is not able to produce a valid modification declaration or authority card, or
  - iii. the vehicle has not been certified to an accepted overseas system as described in [Technical bulletin 13](#).

**Note 1 Definitions**

**Mudguard** means a fitting, inclusive of any portion of the vehicle and of any mudflaps attached, that serves to intercept material thrown up by a wheel more or less in the plane of the wheel.

**Tyre tread** means the portion of a tyre that contacts the road.

**Modify** means to change a vehicle from its original state by altering, substituting, adding or removing a structure, system, component or equipment, but does not include repair.

**Repair** means to restore a damaged or worn vehicle, its structure, systems, components or equipment to within safe tolerance of its condition when manufactured, including replacement with undamaged or new structures, systems, components or equipment.

**Note 2**

Damage on full mudguards fitted to logging trucks is permissible if it is above a horizontal line on top of the tyre (Figure 10-3-5), and that damage is unlikely to result in the mudguard presenting a hazard to road users.

**Table 10-3-1. Modifications that do not require LVV certification**

<b>Fitting of or modification to</b>	<b>LVV certification is not required provided that:</b>
Modified mudguards, including flared wheel arches or the addition of mudguard extensions	<ul style="list-style-type: none"><li>• A mudguard has not been cut during modification, and</li><li>• modified mudguards or extensions have no sharp protrusions, and</li><li>• mudguard extensions are securely attached to the vehicle, and</li><li>• the mudguard/mud flap is no less effective than OE.</li></ul> <p><b>Note:</b> Mudguards flared via rolling do not require certification.</p>
<b>Fitting of or modification to</b>	<b>LVV certification is never required:</b>
Any modification for the purposes of law enforcement or the provision of emergency services	<ul style="list-style-type: none"><li>• in-service requirements for condition and performance must be met.</li></ul>

Figure 10-3-1. Position of individual mudguard in relation to tyre tread

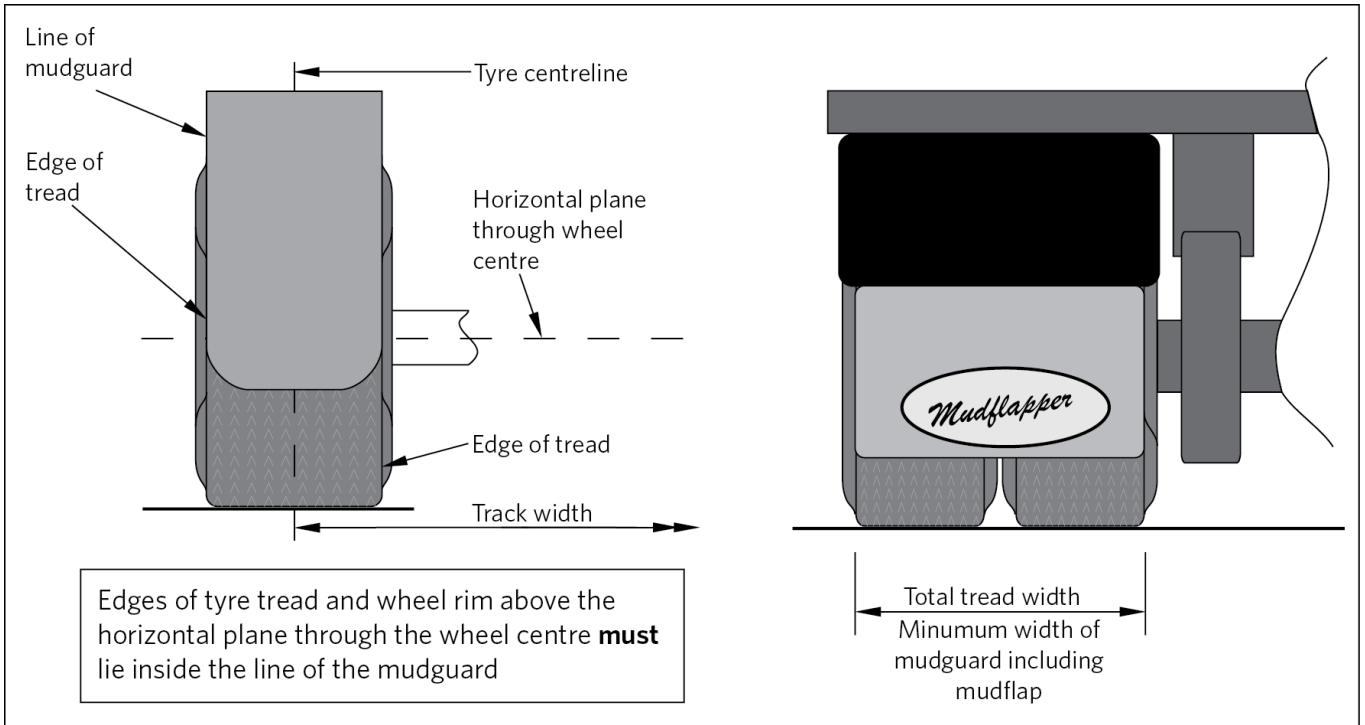

Figure 10-3-2. Position of body panel mudguard in relation to tyre tread

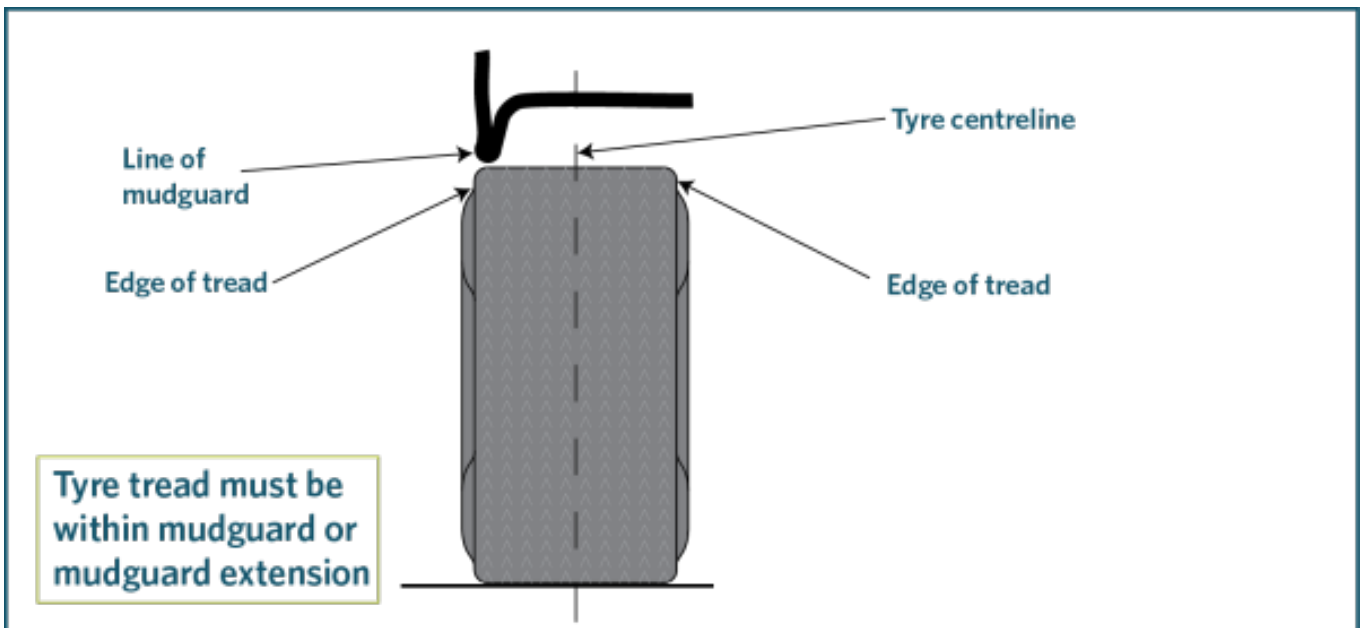

Figure 10-3-3. Size and position of mudguards for the rear wheels of a vehicle fitted with dual wheels or close-spaced multiple wheels

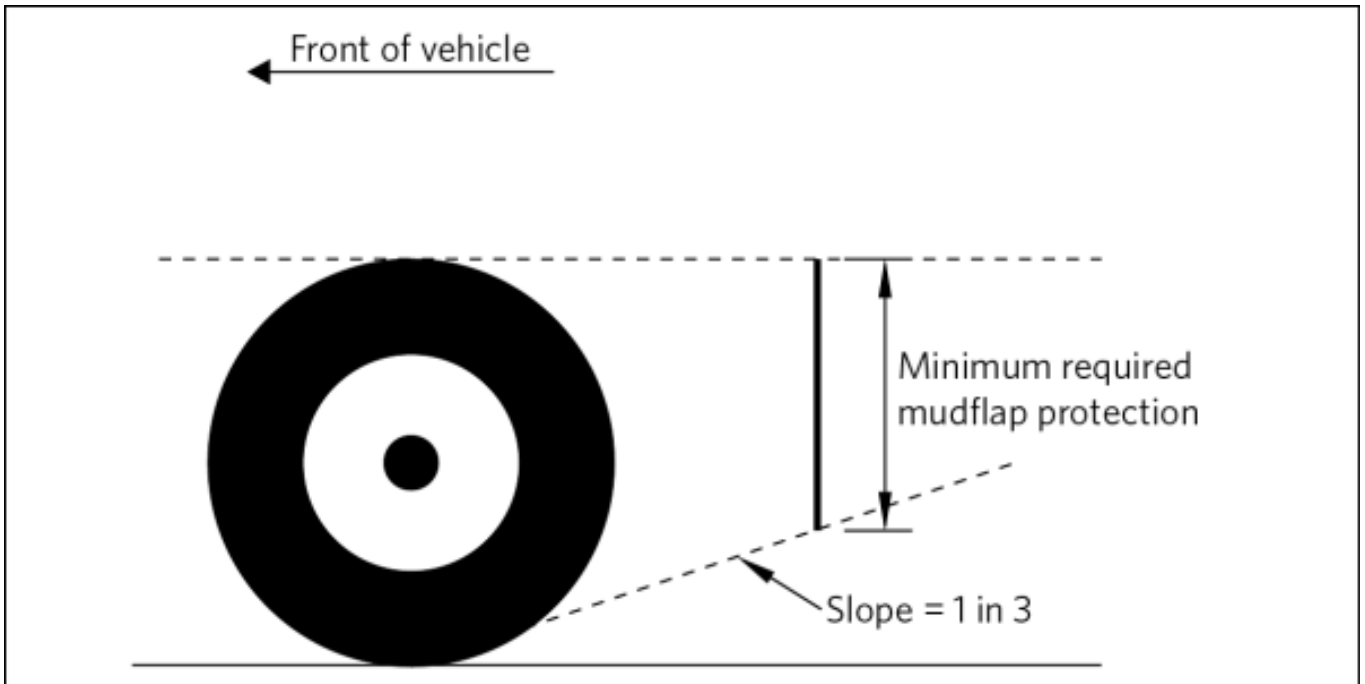

Figure 10-3-4. LVV Authority Card: New Zealand Hot Rod Association



**LV** Low Volume Vehicle Technical Association Inc.

## LOW VOLUME VEHICLE AUTHORITY CARD

The following modifications are authorised under section 2.12 of the Low Volume Vehicle Code (refer to back of Authority Card for conditions of use).

- 1.
- 2.
- 3.
- 4.
- 5.
- 6.
- 7.
- 8.
- 9.

**Name:** \_\_\_\_\_ **Licence #:** \_\_\_\_\_  
**Vehicle:** \_\_\_\_\_ **VIN:** \_\_\_\_\_  
**Issued by:** MotorSport New Zealand **Reg. No (optional):** \_\_\_\_\_  
**Issue date:** \_\_\_\_\_ **Logbook #:** \_\_\_\_\_

**Valid Until:**

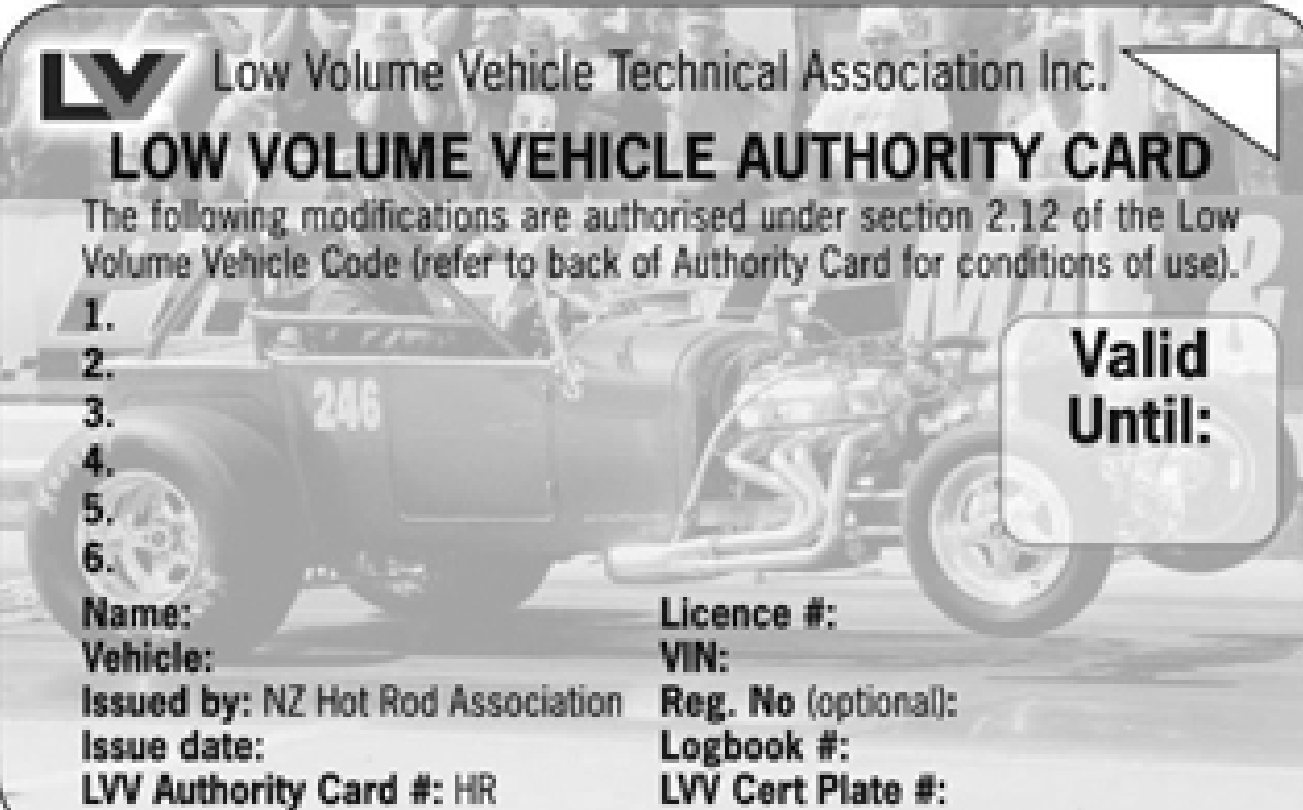

**LV** Low Volume Vehicle Technical Association Inc.

## LOW VOLUME VEHICLE AUTHORITY CARD

The following modifications are authorised under section 2.12 of the Low Volume Vehicle Code (refer to back of Authority Card for conditions of use).

- 1.
- 2.
- 3.
- 4.
- 5.
- 6.

**Name:** \_\_\_\_\_ **Licence #:** \_\_\_\_\_  
**Vehicle:** \_\_\_\_\_ **VIN:** \_\_\_\_\_  
**Issued by:** NZ Hot Rod Association **Reg. No (optional):** \_\_\_\_\_  
**Issue date:** \_\_\_\_\_ **Logbook #:** \_\_\_\_\_  
**LVV Authority Card #:** HR \_\_\_\_\_ **LVV Cert Plate #:** \_\_\_\_\_

**Valid Until:**

Figure 10-3-5. Permissible damage area on logging truck mudguards (Note 2)

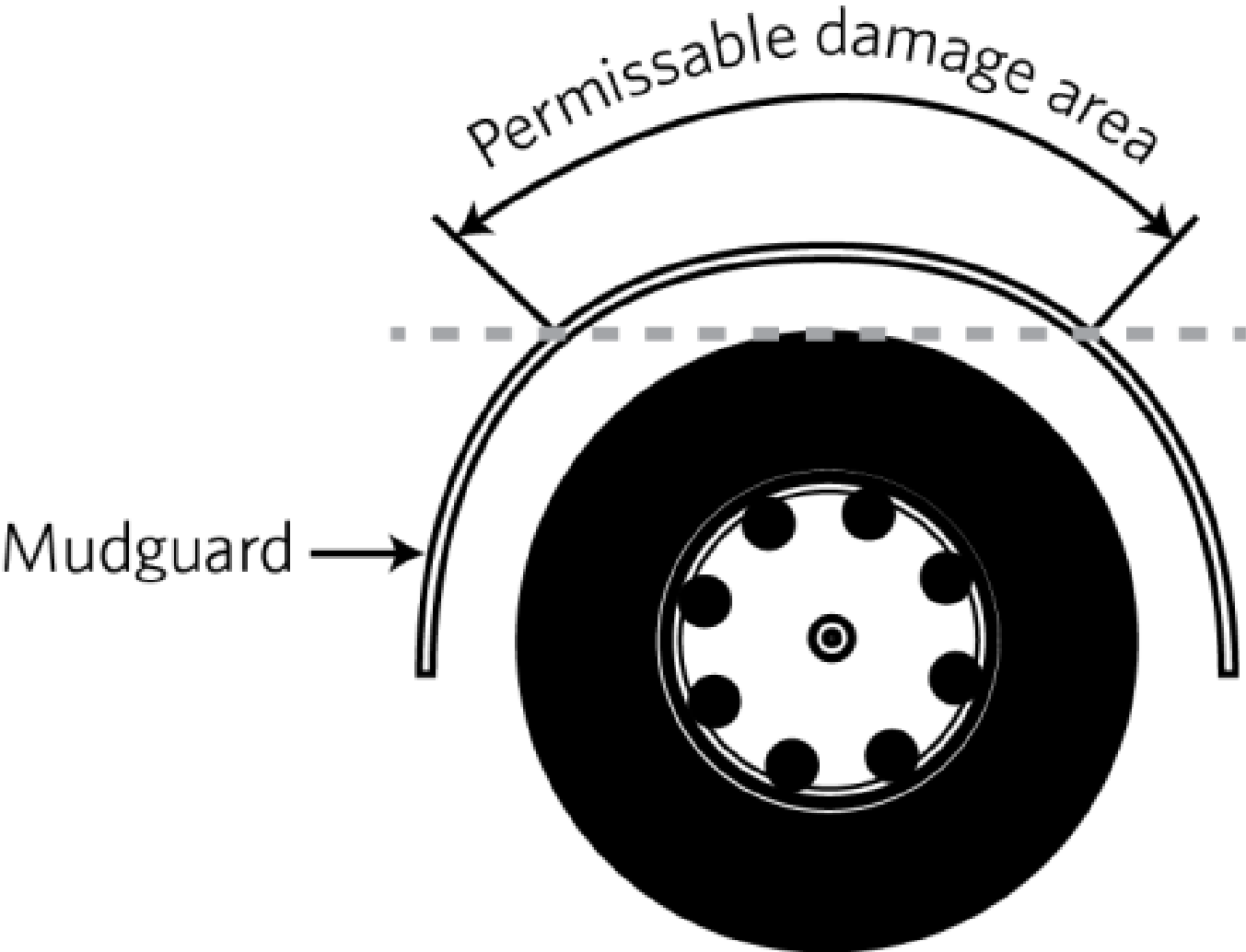

**Figure 10-3-6 . Heavy vehicle mudguard requirements**

**All trucks and trailers**

Where there is no body, deck or other fitting that can serve as a mudguard then a mudguard that meets the definition must be fitted where it is reasonable and practical to fit one.

**Definition:** Mudguard means a fitting, inclusive of any portion of the vehicle and of any mudflaps attached, that serves to intercept material thrown up by a wheel more or less in the plane of the wheel.



**Logging truck exceptions**

- Full mudguards over steer axles and where full mudguards cannot be fitted to the drive axles, partial mudguards may be fitted.
- If the drive axle is twin tyred the mudguard must provide continuous protection from a horizontal line at the top of the tyre to a line rising rearward with a slope of 1:3 from the tyre's contact point with the road, and
- the distance between the tyre and the mudguard must not be more than twice the distance from the centre of the wheel to the road.

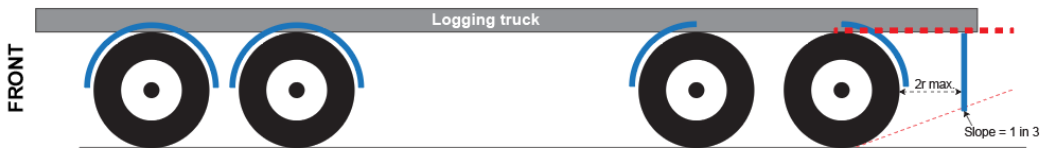

**Logging trailer exceptions**

At least partial mudguards mounted behind the rearmost axle that meet the following requirements:

- the mudguard must provide continuous protection from a horizontal at the top of the tyre to a line rising rearward with a slope of 1 in 3 from the tyre's contact point on the road, and
- the distance between the tyre and the mudguard must not be more than twice the distance from the centre of the wheel to the road.

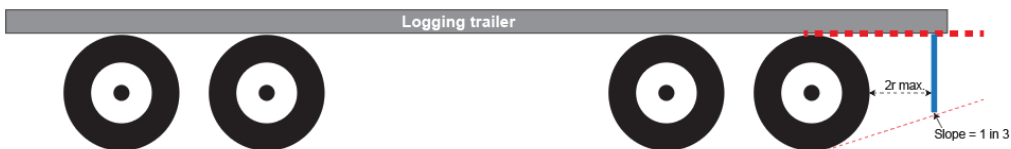

## Summary of legislation

### Applicable legislation

- [Land Transport Rule: Tyres and Wheels 2001](#)
- [Land Transport Rule: Vehicle Equipment 2004](#)

### Mandatory equipment

1. A vehicle must be fitted with a mudguard over each road wheel if it is reasonable and practicable to do so (Note 1).
2. A mudguard must cover no less than the width of the tyre tread on each road wheel (Figure 10-3-1 and Figure 10-3-2).
3. A vehicle fitted with twin tyres or close-spaced multiple tyres must be fitted with a mudguard over each wheel on the rear axle that provides continuous protection from a horizontal line tangent to the top of the tyre tread (Note 2) to a line with a slope of 1 in 3 rising rearward from the tyre's contact point on the road (Figure 10-3-3).
4. A vehicle designed for industrial purposes may be fitted with partial mudguards if the vehicle's construction makes it impracticable to fit full mudguards.
5. The following vehicles are not required to be fitted with mudguards:
  - a) a vehicle in an unfinished condition used under the authority of trade plates and operated in accordance with the Compliance Rule

- b) a vehicle not capable of exceeding a speed of 30 km/h
- c) a vehicle with a valid LVV authority card (Figure 10-3-4).

### **Mudguard condition**

6. A mudguard must be securely fixed to the vehicle and must be constructed so that it does not present a hazard to road users.

### **Modification**

7. A modification that affects a mudguard must be inspected and certified by a Low Volume Vehicle specialist certifier, unless the vehicle:

- a) is excluded from the requirement for LVV certification (Table 10-3-1), and
- b) has been inspected in accordance with the requirements in this manual, including those for equipment, condition and performance.

Page amended **29 April 2020** (see [amendment details](#)).