

Correct as at 7th June 2026. It may be superseded at any time.

Extract taken from: In-service certification (WoF and CoF) > Heavy vehicles > Vision

5 Vision

5-1 Glazing

Reasons for rejection

Mandatory equipment

1. Refer to [general vehicle pages](#).
2. A glazing marking required in Table 5-1-8 or Table 5-1-9 is missing, except for:
 - a) hard plastic glazing behind the driver's seat in a vehicle manufactured before 1 January 1991, or
 - b) markings on any isolation shield (see [general vehicles Table 5-1-6](#)) (Note 3).

Condition

3. Refer to [general vehicle pages](#) (Note 1).
4. A wire-mesh windscreen stoneguard (Figure 5-1-7):
 - a) top edge is **both** above the top of the steering wheel in its highest adjusted position **and** above 225mm measured from the bottom edge of the windscreen, or
 - b) has a mesh size smaller than 12mm (Note 2), or
 - c) makes it difficult to access the windscreen for cleaning.

Performance

5. Refer to [general vehicle pages](#).

Modification

Permitted modifications

6. Refer to [general vehicle pages](#).
7. OE glazing that affects the structural integrity of the vehicle has been permanently removed and:
 - a) is missing proof of HVS certification, ie **the vehicle has been modified or repaired, and:**
 - i. no LANDATA record has been entered, or
 - ii. no valid LT400 form from an HVS certifier of category HVEC or HMCD has been presented.

Windscreen repair

8. Refer to [general vehicle pages](#).

Note 1

With reference to Figure 5-1-8, **for heavy vehicles only**, the upper and lower boundaries of the CVA must be taken as:

- Upper boundary: the lower of 100mm from the edge of the glazing or 900mm from the top of the uncompressed seat cushion
- Lower boundary: the higher of the top of the uncompressed seat cushion or 100mm from the bottom of the windscreen.

Note 2

Objects, whether functional or otherwise (for example signage or badges) must not be attached to a wire-mesh windscreen stoneguard.

Note 3

Waka Kotahi makes no representations about the effectiveness of these installations, whether they are required, or whether they are sufficient for the purposes of meeting health and safety or other requirements. It takes no responsibility for the installation and use of isolation shields.

Container

Table 5-1-8. Required markings for windscreens on heavy vehicles

Vehicle class	Date of manufacture			
	Before 1/1/60	1/1/60–31/12/90	1/1/91–30/6/97	From 1/7/97
MD3, MD4, ME, NB, NC	–	Safety glass with approved trade name or approved standard	Safety glass with approved standard	Laminated glass with approved standard

Table 5-1-9. Required marking for other glazing on heavy vehicles

Vehicle class	Date of manufacture		
	Before 1/2/77	1/2/77–31/12/90	From 1/1/91
MD3 ¹ , MD4 ¹ , ME ¹ , NB, NC	–	Safety glass with approved trade name or approved standard	Safety glass with approved standard

¹ Curved scenic skylights above the cant rail, curved windows at front and rear corners, skylights, louvres and interior partitions may be made of transparent material of a kind that does not shatter. This material is not usually marked.

Figure 5-1-7. Stoneguard measurements

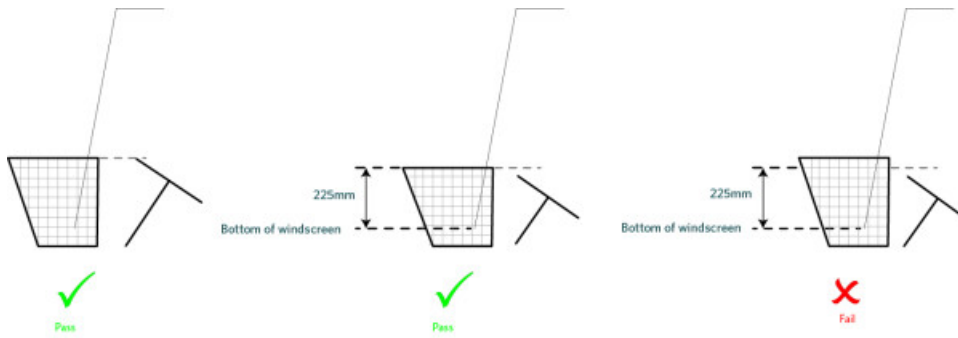
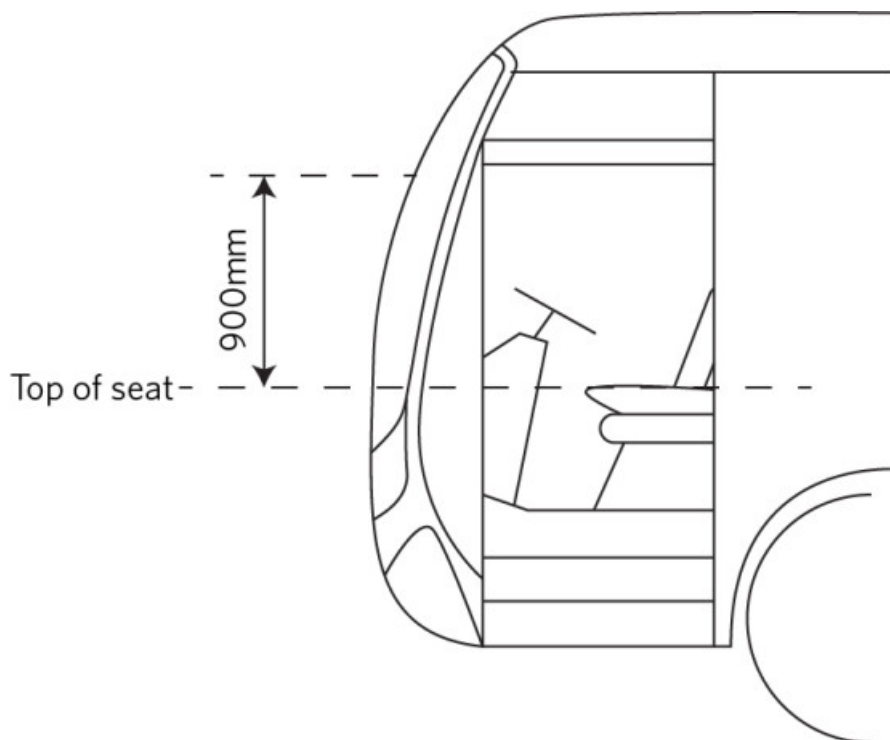

Figure 5-1-8. CVA upper and lower boundaries on a heavy vehicle



Note: Applies to all heavy vehicles, not only buses.

Summary of legislation

Applicable legislation

- [Land Transport Rule: Glazing, Windscreen Wipe and Wash, and Mirrors 1999](#)
- [Land Transport Rule: External Projections 2001](#).

Mandatory equipment

1. Refer to [general vehicle pages](#).
2. A glazing marking required in Table 5-1-8 or Table 5-1-9 is missing, unless it is hard plastic glazing behind the driver's seat in a vehicle manufactured before 1 January 1991.

Condition

3. Refer to [general vehicle pages](#).

Performance

4. Refer to [general vehicle pages](#).

Modification

5. The permanent removal of OE glazing that affects the structural integrity of the vehicle requires certification by an HVS certifier.

Page amended **1 April 2023** (see [amendment details](#)).

5-2 Sun visors

Reasons for rejection

Mandatory equipment

1. A sun visor for the driver's use is not fitted to a vehicle (other than of class LE) which can practicably be fitted with a sun visor (Note 1).

Condition

2. A sun visor:

- a) is insecurely mounted, or
- b) for the driver, cannot be adjusted from the normal driving position, or
- c) cannot maintain its adjusted position, or
- d) has been modified or has deteriorated, and the likelihood of injury to vehicle occupants has not been minimised.

Performance

3. A driver's sun visor does not effectively aid the driver's vision by intercepting the glare from the sun.

Note 1 Definitions

Sun visor means any attachment mounted above the inside of the windscreen and provided for the purpose of shielding the eyes of the driver and other front seat passengers from solar glare.

Modify means to change a vehicle from its original state by altering, substituting, adding or removing a structure, system, component or equipment, but does not include repair.

Repair means to restore a damaged or worn vehicle, its structure, systems, components or equipment to within safe tolerance of its condition when manufactured, including replacement with undamaged or new structures, systems, components or equipment.

Summary of legislation

Applicable legislation

- [Land Transport Rule: Vehicle Equipment 2004](#)
- [Land Transport Rule: Interior Impact 2002](#).

Mandatory equipment

1. A vehicle other than of class LE must be fitted with a sun visor for the driver's use if it is reasonable and practicable to do so (Note 1).

Permitted equipment

2. A vehicle of class LE may be fitted with a sun visor.
3. Additional sun visors may be fitted in other positions.

Condition

4. The condition of a sun visor must be such that the likelihood of injury to occupants is minimised.

Performance

5. A driver's sun visor must be effective.

Modification

6. A sun visor that is not OE or that has been affected by a modification (Note 1):
 - a) must meet the requirements for equipment, condition and performance, and
 - b) does not require LVV specialist certification.

5-3 Windscreen wipe and wash

Reasons for rejection

Mandatory equipment

1. A vehicle that has a windscreen is not fitted with a windscreen wipe system.
2. A vehicle manufactured on or after 1 January 1992 is not fitted with a windscreen wash system.
3. A vehicle manufactured on or after 1 January 1960 is fitted with wipers that are not power driven.

Condition

Windscreen wipe system

4. The wiper operating device is missing.
5. A wiper arm or wiper blade is:

- a) missing, or
- b) insecure, or
- c) damaged so as to affect the performance of the wipers.

6. The wiper operating mechanism is:

- a) missing, or
- b) insecure, or
- c) damaged so as to affect the performance of the wipers.

Windscreen wash system

7. A wash system component is missing or insecure.

8. The wash operating device is missing.

Performance

Windscreen wipe system

9. A windscreen wiper does not wipe the windscreen effectively, preventing adequate forward vision by the driver.

10. The wipe operating device is unable to activate the wipe system.

Windscreen wash system

11. A windscreen wash nozzle does not discharge washer liquid directly onto the windscreen.

12. The wash operating device is unable to activate the wash system.

Modifications

13. A modification affects a windscreen wipe system, and:

- a) is not excluded from the requirements for specialist certification (Table 5-3-1), and
- b) is missing proof of specialist **or accepted overseas** certification, ie:
 - i. the vehicle is not fitted with a valid certification plate, or
 - ii. the operator is not able to produce a valid modification declaration or authority card.

Table 5-3-1. Modifications that do not require specialist certification

Fitting of or modification to:	Specialist certification is never required:
Removal of a windscreen wash system from a vehicle manufactured before 1/1/1992	• in-service requirements for condition and performance must be met.
Any modification for the purposes of law enforcement or the provision of emergency services	

Summary of legislation

Applicable legislation

- [Land Transport Rule: Glazing, Windscreen Wipe and Wash, and Mirrors 1999.](#)

Mandatory equipment

1. A vehicle manufactured before 1 January 1992 that is fitted with a windscreen must have a windscreen wipe system.
2. A vehicle manufactured on or after 1 January 1992 that is fitted with a windscreen must have a windscreen wipe and wash system.
3. Windscreen wipers must be power driven, unless they follow OE specifications in a vehicle manufactured before 1 January 1960.

Permitted equipment

4. A vehicle may be fitted with a wash system when this is not required.

Condition

5. A vehicle's windscreen wipe system must be efficient and within the vehicle manufacturer's operating limits.

Performance

6. The equipment fitted must be capable of keeping an adequate area of the windscreen clean and clear so that the vehicle may be operated safely under all reasonably foreseeable conditions.

Modifications

7. An OE windscreen washing system may be removed from a vehicle manufactured before 1 January 1992.
8. A modification to the windscreen wipe system must be inspected and certified by an specialist certifier unless the vehicle:
 - a) is excluded from the requirement for specialist certification (Table 5-3-1), and
 - b) has been inspected in accordance with the requirements in this manual, including those for equipment, condition, and performance.

5-4 Rear-view mirrors

Reasons for rejection

Mandatory equipment

1. A class MD3, MD4, ME, NB or NC vehicle is not fitted with:
 - a) an outside left-hand rear view mirror, or
 - b) an outside right-hand rear view mirror.
2. An unclassified vehicle is not fitted with at least one rear view mirror.

Permitted equipment

3. Refer to [general vehicle pages](#).

Condition

4. Refer to [general vehicle pages](#).

Performance

5. Refer to [general vehicle pages](#).

Summary of legislation

Applicable legislation

- [Land Transport Rule: Windscreen Wipe and Wash, and Mirrors 1999](#).

Mandatory equipment

1. A class MD3, MD4, ME, NB and NC vehicle must be fitted with an outside left-hand and an outside right-hand rear-view mirror.
2. An unclassified heavy vehicle must be fitted with at least one rear-view mirror.

Permitted equipment

3. Refer to [general vehicle pages](#).

Condition

4. Refer to [general vehicle pages](#).

Performance

5. Refer to [general vehicle pages](#).

Modification and repair

6. A rear-view mirror that is affected by a modification or repair:

- a) must meet the requirements for equipment, condition and performance, and
- b) does not require HVS certification.