

Correct as at 4th June 2026. It may be superseded at any time.

Extract taken from: In-service certification (WoF and CoF) > Motorcycles > Towing connections

12 Towing connections

12-1 Towbar

Reasons for rejection

Mandatory equipment

1. A towbar fitted to a vehicle does not have provision for securely fitting the safety chain from a trailer coupling, except for:

- a) New Zealand Defence Force vehicles
- b) fire-fighting vehicles.

Condition

2. The towbar or towbar mounting:

- a) is not securely attached, or
- b) has a bolt or nut that is missing or significantly corroded, or
- c) has corrosion damage (Note 1) within 150mm of the mounting points, or
- d) is cracked or distorted, or
- e) has any other damage that the vehicle inspector considers has affected the structural integrity of the towbar or its attachment to the vehicle.

3. The towbar coupling (towball):

- a) is not securely attached, or
- b) is worn beyond manufacturer's specifications, or
- c) is significantly corroded, distorted or cracked, or
- d) has a nut that is missing or significantly corroded.

Note 1

Corrosion damage is where the metal has been eaten away, which is evident by pitting. The outward signs of such corrosion damage is typically displayed by the lifting or bubbling of paint. In extreme cases, the area affected by the corrosion damage will fall out and leave a hole.

Table 12-1-1. Requirements for certification (Motorcycle light PSV only)

Towbar/vehicle date	Evidence of certification
<p>Vehicle entered service as a PSV in New Zealand before 1 September 1999 and fitted with a towbar before 1 September 1999</p>	<p>1. A permanently attached plate, indelibly marked with:</p> <ul style="list-style-type: none"> a) manufacturer's name, and b) towbar model number or part number, and c) rating – maximum towed mass (MTM) not exceeding 2000kg <p>Note An uncertified towbar must be identified for private use only, eg on the checksheet.</p>
<p>Vehicle entered service as a PSV in New Zealand on or after 1 September 1999 and fitted with a towbar, or vehicle entered service as a PSV in New Zealand before 1 September 1999 and fitted with a towbar on or after 1 September 1999.</p>	<p>1. A permanently attached plate, indelibly marked with:</p> <ul style="list-style-type: none"> a) manufacturer's name or trademark which clearly identifies the agency or person who has built the towbar, and b) the maximum towed mass (MTM) not exceeding 3500kg, and c) the maximum vertical load applied at the towing ball, and d) vehicle make, model or part number which identifies the vehicle(s) for which the towbar has been designed.

Note An unrated towbar may be assessed, rated and plated by an appropriately qualified engineer.

12-1-1. Towbar and towbar coupling

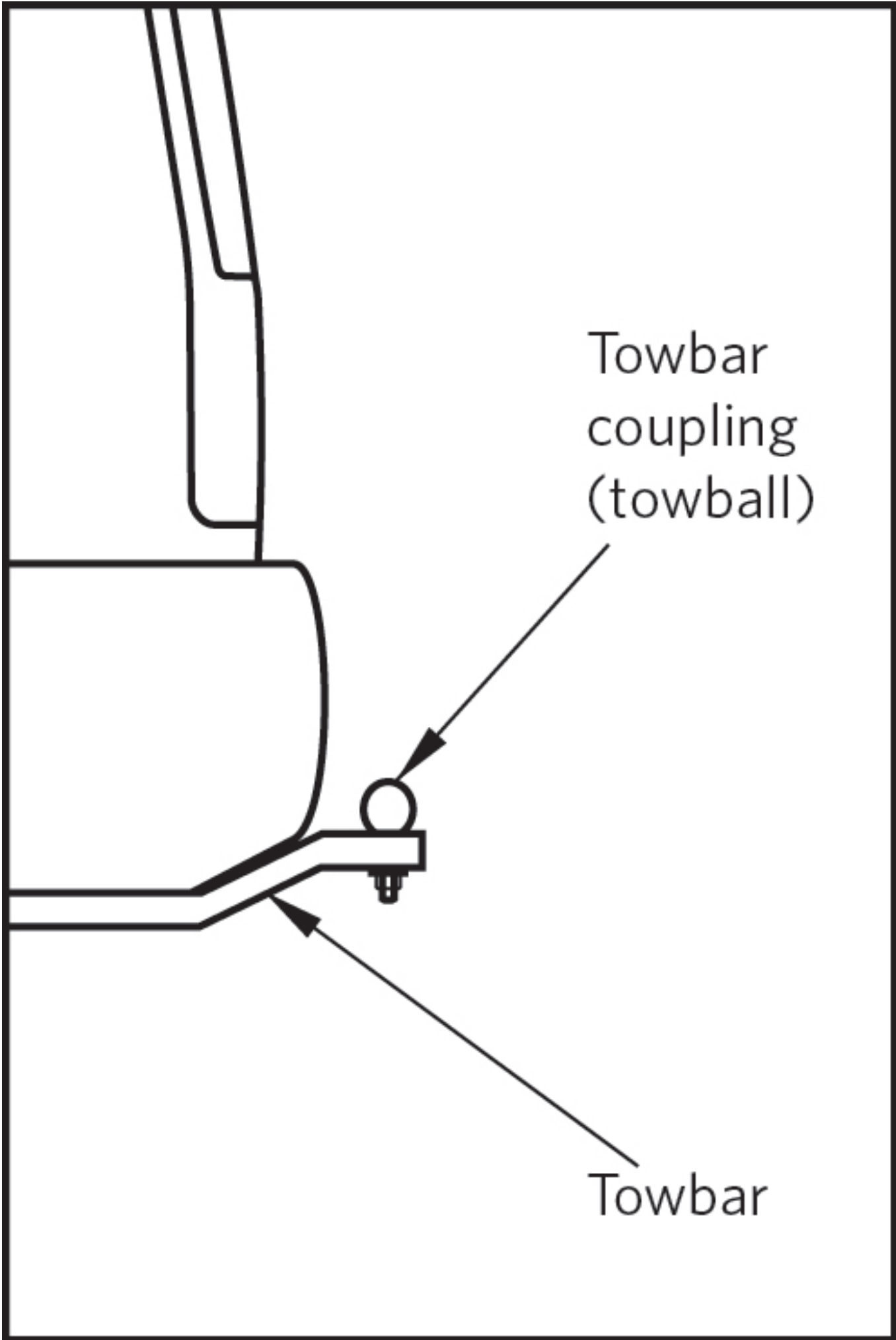

Summary of legislation

Applicable legislation

- [Land Transport Rule: Vehicle Standards Compliance 2002](#), section 7.4.

Mandatory equipment

1. A towbar, if fitted to a vehicle, must have provision for securing the safety chain or cable from a trailer coupling, except if the vehicle is likely to tow any of the following trailers:

- a) a trailer designed for armament purposes by the New Zealand Defence Force
- b) a trailer pump for fire-fighting purposes.

Condition

2. A trailer must be securely attached to the towing vehicle by an adequate coupling.

3. A vehicle must:

- a) be safe to be operated, and
- b) have been constructed using components and materials that are fit for the purpose, and
- c) be within safe tolerance of its state when manufactured or modified.

12-1 Towbar (motorcycle PSV)

Mandatory equipment

1. A towbar that is fitted to a PSV does not show evidence of meeting the requirements of Table 12-1-1.

Condition and performance

2. Refer to [general motorcycle pages](#).

3. A certification plate is:

- a) illegible, or
- b) has details that do not match the vehicle, or
- c) has obvious signs of tampering.

Table 12-1-1. Requirements for certification (Motorcycle light PSV only)

Towbar/vehicle date	Evidence of certification
<p>Vehicle entered service as a PSV in New Zealand before 1 September 1999 and fitted with a towbar before 1 September 1999</p>	<p>1. A permanently attached plate, indelibly marked with:</p> <ul style="list-style-type: none"> a) manufacturer's name, and b) towbar model number or part number, and c) rating – maximum towed mass (MTM) not exceeding 2000kg <p>Note An uncertified towbar must be identified for private use only, eg on the checksheet.</p>
<p>Vehicle entered service as a PSV in New Zealand on or after 1 September 1999 and fitted with a towbar, or vehicle entered service as a PSV in New Zealand before 1 September 1999 and fitted with a towbar on or after 1 September 1999.</p>	<p>1. A permanently attached plate, indelibly marked with:</p> <ul style="list-style-type: none"> a) manufacturer's name or trademark which clearly identifies the agency or person who has built the towbar, and b) the maximum towed mass (MTM) not exceeding 3500kg, and c) the maximum vertical load applied at the towing ball, and d) vehicle make, model or part number which identifies the vehicle(s) for which the towbar has been designed.

Note An unrated towbar may be assessed, rated and plated by an appropriately qualified engineer.

Applicable legislation

- [Land Transport Rule: Passenger Service Vehicles 1999](#)
- St281192 – Exemption from Specified Requirements of the PSV Construction Regulations 1978
- New Zealand Standard 5467: 1993, Code of Practice for Light Trailers
- Ministry of Transport Policy Statement 5.

Mandatory equipment

1. A towbar that is fitted to a PSV must comply with the requirements in Table 12-1-1.

Condition and performance

2. Refer to [general motorcycle pages](#).