

Correct as at 5th June 2026. It may be superseded at any time.

Extract taken from: In-service certification (WoF and CoF) > Heavy vehicles > Load restraints

14 Load restraints

14-1 Load anchorages

Reasons for rejection

Mandatory requirement

1. A load anchorage point does not have evidence of certification to NZS 5444, ie:

a) the load anchorage point was fitted before the last CoF inspection, and after 1 January 1997, and no LANDATA record has been entered,

Note Before 1 January 1997 certification was required but for inspection purposes the LANDATA record need not be checked

or

b) the load anchorage point was fitted after the last CoF inspection and:

- i. a valid LT400 form has not been presented, or
- ii. the HVS certifier was not of category HVEA or HMAD, or

c) there is no valid certification label or plate attached to the vehicle (usually fitted to the left-hand chassis or coaming rail, or to the load platform) as specified in Table 14-1-1.

Mandatory equipment

2. A vehicle constructed to transport a load is not fitted with load anchorage points (hooks, rope rails, twist locks, tie-down rings, keyhole plates or chain slots), unless the vehicle is one of the following:

- a) a vehicle fitted with a body that is specifically designed to contain the transported load without the use of lashings, chains or other devices, such as a tank body or a tipping body for transporting bulk goods (refer to [section 3-1](#))
- b) a vehicle fitted with a stock crate and stock crate retention devices (refer to [section 14-2](#))
- c) a curtain-sided body fitted with a load-rated curtain and curtain anchorage system (refer to [section 14-5](#))
- d) a vehicle fitted with logging bolsters (refer to [section 14-3](#)).

Condition

3. A certification label or plate:

- a) is not indelibly marked, or
- b) is illegible, or
- c) is attached so that it is not easily visible, or

d) has details that do not match the vehicle, or

e) has obvious signs of tampering.

4. A load anchorage component:

a) is missing, or

b) is not securely attached, or

c) is cracked or deformed, or

d) has significant corrosion damage, or

e) is worn beyond manufacturer's specifications.

Modification and repair

5. A modification or repair affects a load anchorage or its attachment and:

a) is not excluded from the requirements for HVS certification (Table 14-1-2), or

b) is not for the purpose of law enforcement or the provision of emergency services, or

c) is missing proof of HVS certification, ie **the vehicle has been modified or repaired, and:**

i. no LANDATA record has been entered, or

ii. no valid LT400 form from an HVS certifier of category HVEA or HMAD has been presented.

Note 1 Definitions

Load-securing equipment means equipment or a device permanently fitted to a vehicle to secure, either by itself or in conjunction with other equipment or devices such as lashings, a load to a vehicle.

Load anchorage point means a device permanently attached to a vehicle to enable a load to be secured or attached to the vehicle.

Table 14-1-1. Minimum certification label and plate details required

<p>NZS 5444: 1989</p>	<p>NZS 5444: 2005</p>
<p>Identity of the manufacturer Rated capacity of the load anchorage points</p>	<p>Any label or plate issued on or after 1 June 2005 and before 1 December 2016 must contain the information below Certificate number HVS identifier Number and capacity of each type of load anchorage point fitted VIN or chassis number Any special conditions if applicable</p>
<p>Identity of the manufacturer Rated capacity of the load anchorage points</p>	<p>Any label or plate issued on or after 1 December 2016 must contain the information below Compliance Certificate number (LT400) HVS identifier Number and capacity of each type of load anchorage point fitted VIN or chassis number Any special conditions if applicable</p>

Table 14-1-2. Requirements for HVS certification

HVS certification is required	HVS certification is not required
<p>1. Fitting of load anchorages</p> <p>2. A repair (by heating or welding) affects a load anchorage or attachment</p> <p>3. A modification affects a load anchorage or attachment</p>	<p>1. Repairs to coaming rails that do not support certified load anchorage points or J-hooks.</p> <p>2. A vehicle fitted with a bin lifting and hooking mechanism does not require HVS certification to NZS 5444, but the bin must be able to be secured safely using a fail-safe system. This may include a hydraulically operated and locked hook or similar, provided the locking device can only be opened by applying a positive and definitive hydraulic pressure.</p> <p>3. Tarpaulin hooks and load restraints fitted inside a box- or van-type body, eg to restrain furniture, are not considered to be load anchorages and therefore do not require HVS certification (it is recommended that tarpaulin hooks and rails are identified to be used only for retaining tarpaulins).</p> <p>4. Any modification or repair likely to have been carried out before 1 January 1997 (modifications and repairs before this date required certification but for inspection purposes the LANDATA record need not be checked).</p> <p>5. Any repair or modification not listed in the left-hand column unless the vehicle inspector considers that certification is required because the modification or repair has affected the vehicle's safety performance (a second opinion from an expert may be needed, eg the manufacturer's representative, or a reputable workshop).</p>

Summary of legislation

Applicable legislation

- [Land Transport Rule: Heavy Vehicles 2004](#)
- New Zealand Standard 5444: 1989, Load Anchorage Points for Heavy Vehicles
- New Zealand Standard 5444: 2005, Load Anchorage Points for Heavy Vehicles (applicable from 1 June 2005).

Mandatory requirement

1. Load anchorage points (hooks, rope rails, twist locks, tie-down rings, keyhole plates and chain slots) must comply with and be certified to NZS 5444.

Mandatory equipment

2. A vehicle that is constructed to transport a load must be fitted with load securing equipment (Note 1).
3. A vehicle must have load anchorage points that are certified by an HVS certifier as complying with New Zealand standard 5444, unless the vehicle is one of the following:
- a) a vehicle fitted with a body that is specifically designed to contain the transported load without the use of lashings, chains or other devices, such as a tank body or a tipping body for transporting bulk goods (refer to [section 3-1](#)), or

- b) a vehicle fitted with a stock crate and stock crate retention devices (refer to [section 14-2](#)), or
- c) a curtain-sided body fitted with a load-rated curtain and curtain anchorage system (refer to [section 14-5](#)), or
- d) a vehicle fitted with logging bolsters (refer to [section 14-3](#)).

4. A load anchorage must be certified by an HVS certifier of category HMLD or HVEA.

Condition

5. A certification label or plate must be:

- a) clearly and indelibly marked, and
- b) securely attached.

6. Load securing equipment that is fitted to a vehicle must be constructed to ensure that the load can be securely contained on the vehicle under all conditions of loading and operation for which the vehicle was constructed.

Modification and repair

7. A modification or repair that affects a load anchorage point must be inspected and certified by an HVS certifier of category HVEA or HMAD unless the vehicle:

- a) is excluded from the requirement for HVS certification (Table 14-1-2), and
- b) has been inspected in accordance with the requirements in this manual, including those for equipment, condition and performance.

Page amended **1 April 2023** (see [amendment details](#))

14-2 Stock crates and stock crate retention devices

Reasons for rejection

Mandatory equipment

(see [Technical bulletin 7: Stock crate retention](#))

1. A stock crate, including its retention devices (Figure 14-2-1), fitted to a vehicle with a GVM of 6000 kg or more, has no manufacturer's plate certifying construction in accordance with NZS 5413, that specifies at least all of the following details:

- company name
- stock crate serial number
- date of manufacture of stock crate
- restraint capacity total in kilograms (not required for monocoque stock crates)
- restraint capacity individual in kilograms (not required for monocoque stock crates)
- number of restraints per side (not required for monocoque stock crates).

2. Stock crate anchorage points fitted to the deck have not been certified to NZS 5444, ie:

- a) the stock crate anchorage points were fitted before the last CoF inspection, and after 1 January 1997, and there is no LANDATA record,

Note Before 1 January 1997 certification was required but for inspection purposes the LANDATA record need not be checked

or

b) the stock crate anchorage points were fitted after the last CoF inspection and:

i. a valid LT400 form is not presented, or

ii. the HVS certifier was not of category HVEA or HMAD, or

iii. there is no valid certification plate/label attached to the stock crate as required in Table 14-2-1. Refer to [Technical Bulletin 7: Stock crate certification](#) for details on the plating requirements for vehicles fitted with stock crates.

Condition

3. A certification label or plate:

a) is not indelibly marked, or

b) is illegible, or

c) is attached so that it is not easily visible, or

d) has details that do not match the vehicle, or

e) has obvious signs of tampering.

4. The stock crate's external doors:

a) are not securely attached to the stock crate body, or

b) do not remain secure in a closed or locked position.

5. A J-hook assembly or other retention device, or an anchorage point:

a) is not securely attached, or

b) has a bush, fastener, washer, J-hook or other component missing or significantly corroded, or

c) is cracked or distorted, or

d) has cracks or corrosion damage on the stock crate within 150mm of the retention device attachment point, or

e) is not of a type suitable for retaining the stock crate, or

f) is worn beyond manufacturer's specifications.

Modification and repair

6. A modification or repair affects the stock crate or its retention devices and:

a) is not excluded from the requirements for HVS certification (Table 14-2-2), or

b) is not for the purpose of law enforcement or the provision of emergency services, or

c) is missing proof of HVS certification, ie **the vehicle has been modified or repaired, and:**

i. no LANDATA record has been entered, or

ii. no valid LT400 form from an HVS certifier of category HVEA or HMAD has been presented.

Note 1 Definitions

Body means the part of the vehicle that is designed for the use and accommodation of the occupants or to hold any goods. It comprises the load platform/deck, headboard, sideboards, tailgate, coaming rails, cross-members, runners and attachment to the chassis.

Chassis means the structural lower part of a vehicle to which the running gear and, as applicable, engine, transmission, steering system and body may be attached.

J-hook means a retention device fabricated from metal for the retention of stock crates to the vehicle load platform, mounted in such a way as to be fixed either inside or outside the coaming rail vertically and tensioned through a bush on the crate structure by way of a threaded fastener.

Load anchorage point means a device permanently attached to a vehicle to enable a load to be secured or attached to the vehicle.

Table 14-2-1. Minimum certification label and plate details required

NZS 5444: 1989	NZS 5444: 2005
Identity of the manufacturer Rated capacity of the load anchorage points	Certificate number HVS identifier Number and capacity of each type of load anchorage point fitted VIN or chassis number Any special conditions if applicable Note Any label or plate issued on or after 1 June 2005 must contain the above information.

Table 14-2-2. Requirements for HVS certification

HVS certification is required	HVS certification is not required
1. Stock crate retention devices that have been modified or repaired resulting in altered load ratings	1. A stock crate retention device has been repaired or modified, and the HVS Certifier can confirm that the load ratings are still correct. 2. Any modification or repair likely to have been carried out before 1 January 1997 (modifications and repairs before this date generally required certification but for inspection purposes the LANDATA record need not be checked). 3. Any repair or modification not listed in the left-hand column unless the vehicle inspector considers that certification is required because the modification or repair has affected the vehicle's safety performance (a second opinion from an expert may be needed, eg the manufacturer's representative, or a reputable workshop).

Figure 14-2-1. Types of acceptable J-hooks

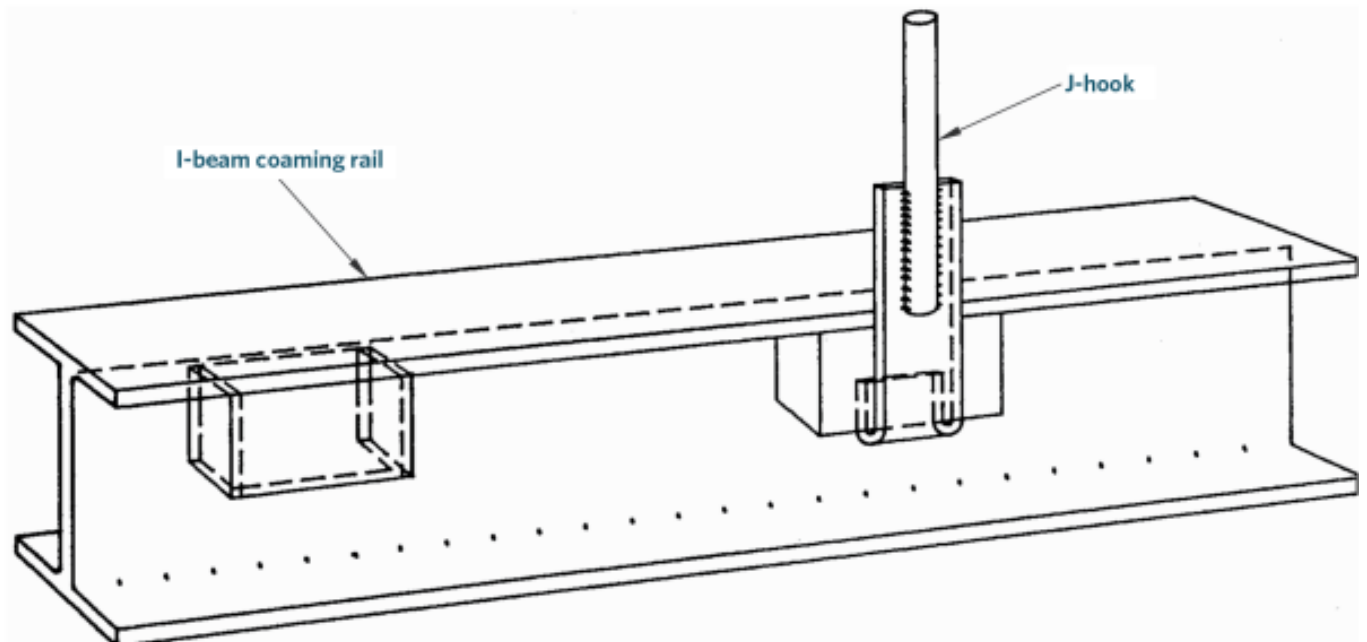
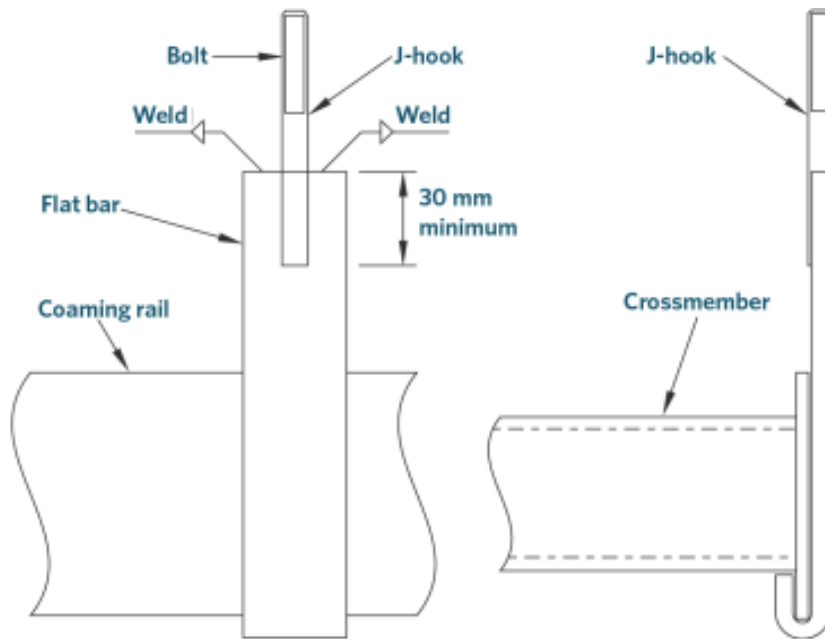

Summary of legislation

Applicable legislation

- [Land Transport Rule: Heavy Vehicles 2004](#)
- New Zealand Standard 5413: 1993, Code of Practice for the Manufacture and Use of Stock crates on Heavy Vehicles
- New Zealand Standard 5444: 1989, Load Anchorage Points for Heavy Vehicles
- New Zealand Standard 5444: 2005, Load Anchorage Points for Heavy Vehicles.

Mandatory equipment

1. A stock crate and its retention devices, if fitted to a vehicle with a GVM of 6000 kg or more, or be fitted with a stock crate plate (see [Technical bulletin: Stock crate retention](#)).
2. Stock crate anchorage points fitted to the deck of a vehicle must comply with and be certified to NZS 5444.
3. There is no valid certification plate/label attached to the stock crate or vehicle as required in Table 14-2-1.
4. Stock crate retention devices must be attached to the crate structure so as to transmit the restraint forces to the vehicle load platform or basic vehicle structure.

Condition

5. External doors shall be firmly fixed to prevent stock from being ejected onto the roadway.
6. Load securing equipment must be constructed to ensure that the load can be safely contained on the vehicle under all conditions of loading and operation for which the vehicle was constructed.

Modification and repair

7. A modification or repair that affects a stock crate anchorage point must be inspected and certified by an HVS certifier of category HVEA or HMAD unless the vehicle:
 - a) is excluded from the requirement for HVS certification (Table 14-2-2), and
 - b) has been inspected in accordance with the requirements in this manual, including those for equipment, condition and performance.

Page amended **1 April 2023** (see [amendment details](#))

14-3 Log bolsters

Reasons for rejection

Mandatory requirement

1. A logging bolster attachment fitted to a vehicle that is required to be certified in Table 14-3-1 does not have evidence of certification.
2. A logging bolster attachment fitted to a vehicle certified to the Bolster Attachment Code (issue 1 May 2001 and issue 2 November 2010) does not have evidence of certification, ie:
 - a) the attachment was fitted before the last CoF inspection and there is no LANDATA record of the certification, or
 - b) the attachment was fitted after the last CoF inspection and:
 - i. a valid LT400 form is not presented, or
 - ii. the HVS Certifier was not of category HVEL or HMLD, or
 - c) individual bolsters are not stamped, indelibly labelled or marked to clearly identify their serial numbers, or
 - d) individual bolster attachments are not stamped, indelibly labelled or marked to clearly identify their serial numbers, or
 - e) the vehicle is not fitted on the left-hand chassis rail with at least one tag clearly identifying the bolsters, bolster attachments, bolster rating, HVS Certifier, bolster manufacturer, vehicle and expiry date.

3. A logging bolster attachment fitted to a vehicle certified to the Bolster Attachment Code (issue 27 November 1998) does not have evidence of certification, ie:

a) there is no LANDATA record of the certification, or

b) individual bolsters are not stamped, indelibly labelled or marked to clearly identify the bolster manufacturer, bolster serial number and rated bolster load, or

c) the vehicle is not fitted on the left-hand chassis rail with at least one tag to clearly identify the bolsters, bolster attachment, vehicle and expiry date.

4. A logging bolster attachment on a long-log logging vehicle fitted with a convertible (sliding or folding) bolster does not have evidence of certification required in Table 14-3-1, ie there is no LANDATA record of the certification.

Condition

5. A required certification label, plate, or marking is:

a) illegible, or

b) incorrect, eg serial numbers differ between the label and the bolsters, or

c) expired.

6. A log bolster or log bolster mounting, including a component such as a load cell, weld and fastener:

a) is missing, or

b) is not securely attached, or

c) is cracked or deformed, or

d) has significant corrosion damage, or

e) is worn beyond manufacturer's specifications, or

f) has excessive wear between mating surfaces.

7. A sliding bolster locking device is:

a) missing, or

b) not effective, or

c) of an unacceptable type, eg air or hydraulic slide cylinder or chain drives.

Modification and repair

8. A modification or repair affects the log bolster or its attachment and:

a) is not excluded from the requirements for HVS certification (Table 14-3-2), or

b) is not for the purpose of law enforcement or the provision of emergency services, or

c) is missing proof of HVS certification, ie **the vehicle has been modified or repaired, and:**

i. no LANDATA record has been entered, or

ii. no valid LT400 form from an HVS certifier of category HVEL or HMLD has been presented.

Note 1

A convertible bolster is usually slid to a different position or dropped down to allow long logs to span two trailers.

Note 2

Logging bolster means a vertically orientated member attached to a vehicle that is used to secure loads of timber logs.

Table 14-3-1. Logging bolster attachment certification requirements

Fitted before 1 October 1999	Fitted 1 October 1999– 30 April 2001	Fitted from 1 May 2001– 30 September 2011	Fitted from 1 October 2011
No certification	<p>Either:</p> <ul style="list-style-type: none"> • Bolster Attachment Code (issue 27 November 1998), or • Bolster Attachment Code (issue 1 May 2001), or • optional for convertible bolsters on long-log logging vehicles: <ul style="list-style-type: none"> ○ certification that the same design of bolster attachments has successfully completed 250,000km of service on a single vehicle without indications of fatigue or failure. 	<p>All bolster attachments:</p> <ul style="list-style-type: none"> • Bolster Attachment Code (issue 1 May 2001), or • optional for convertible bolsters on long-log logging vehicles: <ul style="list-style-type: none"> ○ certification that the same design of bolster attachments has successfully completed 250,000km of service on a single vehicle without indications of fatigue or failure. 	<p>All bolster attachments:</p> <ul style="list-style-type: none"> • Bolster Attachment Code (issue 2 November 2010), or • optional for convertible bolsters on long-log logging vehicles: <ul style="list-style-type: none"> ○ certification that the same design of bolster attachments has successfully completed 250,000km of service on a single vehicle without indications of fatigue or failure.

Table 14-3-2. Requirements for HVS certification

HVS certification is required	HVS certification is not required
1. Any repairs to the bolster attachments	1. Where a fastener fails the inspection, the CoF inspector must request a written report from an HVS certifier of category HVEL or HMLD who will disassemble the fasteners and confirm that: a) movable parts such as lock pins have been checked for proper operation and engagement, and b) mating parts seat correctly, and c) fasteners have been fitted to manufacturer's specifications and bolt torques are correct, and d) any other manufacturer's requirements have been complied with. 2. Any modification or repair likely to have been carried out before 1 October 1999. 3. Any repair or modification not listed in the left-hand column unless the vehicle inspector considers that certification is required because the modification or repair has affected the vehicle's safety performance (a second opinion from an expert may be needed, for example the manufacturer's representative, or a reputable workshop).

Summary of legislation

Applicable legislation

- [Land Transport Rule: Heavy Vehicles 2004](#)
- Bolster Attachment Code, issue 27 November 1998
- Bolster Attachment Code, issue 1 May 2001
- Bolster Attachment Code, issue 2 November 2010
- New Zealand Gazette, 14 January 1999, issue 1, page 64
- New Zealand Gazette, 27 May 1999, issue 60, page 1431
- New Zealand Gazette, 26 April 2001, issue 43, page 957.

Mandatory requirement

1. A logging bolster attachment fitted to a vehicle must comply with the requirements in Table 14-3-1.
2. Certification of a logging bolster attachment must be by an HVS certifier of category HVEL or HMLD .

Mandatory equipment

Bolster Attachment Code (issue 27 November 1998)

3. Individual bolsters must be stamped, indelibly labelled or marked to clearly identify the:

a) bolster manufacturer, and

b) bolster serial number, and

c) rated bolster load.

4. The vehicle must be fitted, on the left-hand side chassis rail as far as practicable in line with the front of the coaming rail, with at least one tag identifying the:

a) bolsters, and

b) bolster attachment, and

c) vehicle, and

d) expiry date.

Bolster Attachment Code (issue 1 May 2001 and issue 2 November 2010)

5. Individual bolsters must be stamped, indelibly labelled or marked to clearly identify their serial number.

6. Individual bolster mounts must be stamped, indelibly labelled or marked to clearly identify their serial number.

7. The vehicle must be fitted with at least one tag identifying the bolsters, bolster attachments, bolster rating, the HVS certifier, the bolster manufacturer, the vehicle and the expiry date.

Condition

8. Load-securing equipment that is fitted to a vehicle must be constructed to ensure that the load can be securely contained on the vehicle under all conditions of loading and operation for which the vehicle was constructed.

9. A load-bearing structure must be of adequate strength for all conditions and loading for which the vehicle was constructed.

Modification and repair

10. A modification or repair that affects a log bolster attachment must be inspected and certified by an HVS certifier of category HVEL or HMLD , unless the vehicle:

a) is excluded from the requirement for HVS certification (Table 14-3-2), and

b) has been inspected in accordance with the requirements in this manual, including those for equipment, condition and performance.

Page amended **1 April 2023** (see [amendment details](#))

14-4 Cab-guards, headboards, sideboards and tailboards

Reasons for rejection

Mandatory equipment

1. A logging truck is not fitted with a cab guard, or the cab guard:

a) is not attached to the chassis, or

b) is not at least as wide and as high as the cab, or

c) has apertures that could allow any forward-moving logs to pass through the cab guard.

Condition

2. A cab guard on a logging truck, or a headboard, sideboard or tailboard:
 - a) is not securely attached, or
 - b) has a fastener that is missing or loose, or
 - c) is cracked or significantly distorted or corroded.

Note 1 Definitions

Cab guard means a structure attached to a vehicle that provides protection to the cab occupants from the effects of load impact and may include a headboard.

Headboard means the substantially vertical part of the forward end of a flat-deck or curtain-sided body of a vehicle.

Sideboard means the substantially vertical part of the side of a flat-deck body of a vehicle.

Tailboard means the substantially vertical part of the rear end of a flat-deck or curtain-sided body of a vehicle.

Summary of legislation

Applicable legislation

- [Land Transport Rule: Heavy Vehicles 2004](#).

Mandatory equipment

1. A vehicle constructed for the purpose of transporting timber logs must be fitted with a cab guard that:
 - a) is attached to the chassis, and
 - b) is at least as wide and as high as the cab, and
 - c) does not have apertures that could allow any forward-moving logs to pass through the cab guard.

Condition

2. A cab guard on a logging truck, and its attachment to the chassis:
 - a) must be strong enough to withstand load impact during loading, unloading and emergency braking, and
 - b) must not adversely affect the strength and durability of the chassis or cause damage to the chassis during heavy load impact.
3. A headboard, sideboard or tailboard fitted to a vehicle for the purpose of restraining a load on that vehicle must be of adequate strength to withstand load forces without incurring permanent deformation.
4. A headboard, sideboard or tailboard must be fitted to a vehicle in a way that ensures that the parts of the vehicle to which it is attached are able to withstand the forces exerted by the headboard, sideboard or tailboard without incurring permanent deformation.

14-5 Curtain systems

Reasons for rejection

Condition

1. A load-rated curtain (Note 1) (Note 2):
 - a) is ripped, or
 - b) has deteriorated, resulting in weakening of the curtain material, eg crazing, brittleness or stiffness, or
 - c) has become detached from the frame, or
 - d) has been poorly repaired.
2. A load-rated curtain-tensioning system component:
 - a) is missing, or
 - b) is not securely attached, or
 - c) is damaged, cracked or deformed, or
 - d) has significant corrosion damage, or
 - e) is worn beyond manufacturer's specifications, or
 - f) does not function correctly.
3. A non-load-rated curtain has deteriorated to such an extent that parts could come loose (Note 3).

Note 1

For the purposes of this inspection, a **load-rated curtain** is one that has labelling that includes the manufacturer's load rating in kilograms per metre.

Note 2

Advice from the curtain manufacturer may be required in case of doubt about damage and deterioration limits and quality of repairs.

Note 3

For curtain siders that are not load rated, refer to section [14-1 Load anchorages](#) for requirements.

Summary of legislation

Applicable legislation

- [Land Transport Rule: Heavy Vehicles 2004](#).

Mandatory equipment

1. If a vehicle has a curtain-sided body that is constructed to secure a load on a vehicle, each curtain and curtain anchorage system must:

- a) have a manufacturer's load rating appropriate for all conditions of loading and operation of the vehicle, and
- b) be clearly marked with the manufacturer's load rating in kilograms per metre, in a position on the curtain that is readily accessible for inspection purposes.

Condition

2. Load-securing equipment that is fitted to a vehicle must be constructed to ensure that the load can be securely contained on the vehicle under all conditions of loading and operation for which the vehicle was constructed.